

# DEVELOPMENT PLAN FOR

# THE SHOPS at BROOKSIDE - BLOCK A

## PHASE III - NORTH BUILDING

### SWC CR N 600 W & CR W 900 N, McCORDSVILLE IN 46055

PLAN SHEET INDEX	
C0.0	TITLE SHEET
C2.0	SITE PLAN
C3.0	GRADING & DRAINAGE PLAN
C4.0	STORMWATER POLLUTION PREVENTION PLAN
C4.1	STORMWATER POLLUTION PREVENTION DETAILS
C4.2	STORMWATER POLLUTION PREVENTION NOTES
C5.0	UTILITY PLAN
C7.0-C7.2	GENERAL DETAILS
C9.0	SPECIFICATIONS
L1.0	LANDSCAPE PLAN
E101	SITE LIGHTING PLAN (BY OTHERS)
TOPO	TOPOGRAPHIC SURVEY BY CROSSROAD ENGINEERS (03/11/2024)

REFERENCE STANDARDS/SPECIFICATIONS:  
 TOWN OF MCCORDSVILLE CONSTRUCTION STANDARDS & SPECIFICATIONS (10 SHEETS)  
 CITIZENS ENERGY GROUP WATER STANDARDS MANUALS

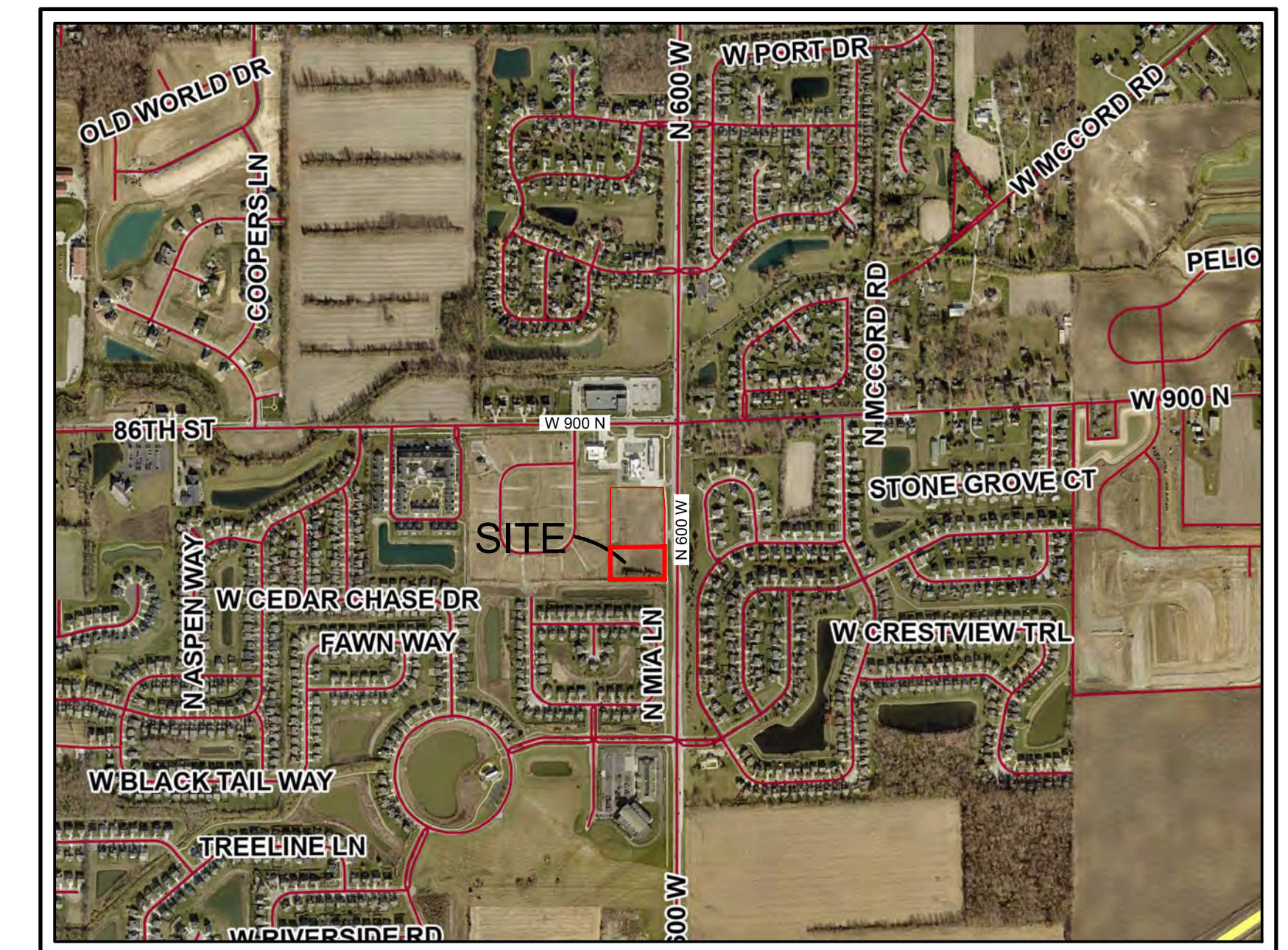

VICINITY MAP  
 SCALE: 1" = 1000' NORTH

#### LAND DESCRIPTION

BLOCK A IN THE VILLAGES OF BROOKSIDE SECTION 16 RECORDED AS INSTRUMENT NO. 2022-12878, PLAT CABINET D, PAGE 210 IN THE RECORDER'S OFFICE OF HANCOCK COUNTY, INDIANA.

#### DEVELOPMENT SUMMARY

PROPOSED USE: RETAIL-SMALL  
 BUILDING(S) GROSS SQUARE FOOTAGE: = 3,200± S.F.  
 TOTAL SITE AREA = 5.69± Ac.  
 OPEN SPACE AREA = x.xx± Ac. (xx% of TOTAL LOT AREA)  
 IMPERVIOUS AREA COVERAGE = x.xx± Ac. (xx%)  
 CURRENT ZONING = VILLAGES AT BROOKSIDE PUD-AMENDMENT

PARKING SPACES PROVIDED = 33  
 PARKING SPACES REQUIRED = 22 (1 PER EMPLOYEE + 1 / 3 SEATS)  
 TENANT SEATING = 42; 8 EMPLOYEES

ANTICIPATED CONSTRUCTION START/END DATE:  
 JANUARY, 2026 / JULY 2026



PROJECT LOCATION

PROJECT DEVELOPER:  
**BDC REALTY GROUP, LLC**  
 6274 S Fox Chase  
 Pendleton, Indiana 46064

ENGINEER:

**CivilSite**  
 GROUP, INC.

718 Adams Street, Suite E  
 Carmel, Indiana 46032  
 Phone: (317) 810-1677  
 Email: bcross@civilsite.net

ARCHITECT:  
**INTEGRITY DESIGN, LLC**  
 3128 Nichol Avenue  
 Anderson, Indiana 46011  
 Ph: (765) 608-3001

SURVEYOR:

Crossroad Engineers, P.C.  
 3417 Sherman Drive  
 Beech Grove, IN 46107  
 Contact: G.W. Charles, PE, PS  
 Phone: (317) 780-1555  
 Email: gwcharles@crossroadengineers.com

#### UTILITY CONTACTS

Drainage & Streets:  
 Town of McCordsville - Engineering  
 6280 W 800 N  
 McCordsville, IN 46055  
 (317) 335-3604

Electric / Telecom:  
 NineStar Connect - Rusty Hansen  
 2243 E Main St,  
 Greenfield, IN 46140  
 (317) 326-3131  
 KHansen@ninestarconnect.com

Natural Gas:  
 Centerpoint Energy

Wastewater & Water:  
 Citizens Energy Group/CWA Authority, Inc.  
 2150 Dr. Martin Luther King Jr St  
 Indianapolis, IN 46202  
 Brad Hostetler - (317) 927-4351  
 bhostetler@citizensenergygroup.com

Streets:  
 Town of McCordsville  
 Hancock County Highway Department

#### DRAINAGE TILE NOTE

ALL DRAINAGE TILES ENCOUNTERED ON PROJECT SITE WILL BE PROVIDED A POSITIVE OUTLET.

#### STANDARDS

THE TOWN OF MCCORDSVILLE & INDIAN STANDARDS SHALL BE INCORPORATED BY REFERENCE INTO THESE PLANS FOR CONSTRUCTION ACTIVITY THROUGHOUT THE SITE AND INDIAN RIGHT-OF-WAY

#### SPECIFICATIONS

NO ALTERNATE SPECIFICATIONS OR MATERIALS OR NEW MATERIALS MAY BE USED WITHOUT THE EXPRESS WRITTEN APPROVAL FROM THE TOWN OF PENDLETON PRIOR TO THE COMPLETION OF WORK.

INDIANA DEPARTMENT OF TRANSPORTATION LATEST EDITION OF SPECIFICATIONS & STANDARDS TO BE USED DURING CONSTRUCTION WITH THESE PLAN DOCUMENTS

REVISION RECORD				
REV	DATE	DESCRIPTION	DES BY	APP BY
1	11/04/25	TAC REVIEW REVISIONS	BSC	BSC

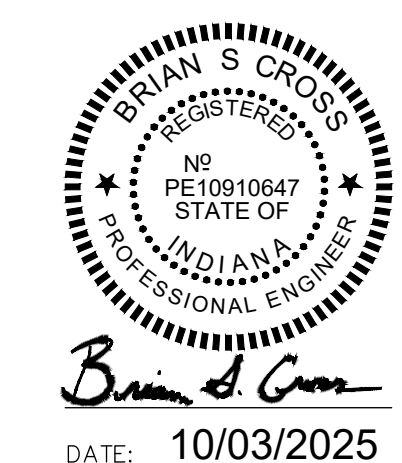

DATE: 10/03/2025

CSG PROJECT NUMBER  
**BRG.008**

DRAWING NUMBER  
**C0.0**  
 SHEET 1 OF 24



**EXISTING CONDITIONS NOTE**

CONTRACTOR TO VERIFY ALL EXISTING CONDITIONS, INCLUDING UTILITIES AND DRAINAGE INFRASTRUCTURE BEFORE COMMENCING WITH CONSTRUCTION. CONTRACTOR TO NOTIFY ENGINEER OF ANY DISCREPANCIES.

**TOPOGRAPHIC & BOUNDARY NOTE**

ALL EXISTING HORIZONTAL AND VERTICAL INFORMATION HAS BEEN SHOWN PER A TOPOGRAPHIC SURVEY DATED 03/11/2024 PREPARED BY CROSSROAD ENGINEER, P.C.; THEREFORE, CIVIL SITE GROUP, INC. CANNOT BE HELD RESPONSIBLE IF ACTUAL HORIZONTAL AND VERTICAL DATA IS DIFFERENT FROM THAT SHOWN ON THESE PLANS. CONTRACTOR IS RESPONSIBLE FOR FIELD VERIFICATION OF ALL EXISTING CONDITIONS PRIOR TO COMMENCING WITH CONSTRUCTION.

**FLOOD NOTE**

THIS LOT LIES ENTIRELY IN FLOOD HAZARD ZONE "X" AS SCALED FROM THE FLOOD INSURANCE RATE MAP (FIRM) FOR HANCOCK COUNTY, INDIANA, COMMUNITY NUMBER 180468, MAP NUMBER 18059C00160, PANEL NUMBER 0016 D, DATED DECEMBER 4, 2007. REFERENCE NFIP FIRM MAP #18059C00160, EFFECTIVE DATE: DECEMBER 4, 2007

**GRADING & UTILITY NOTE**

CONTRACTOR TO VERIFY THE DEPTH AND LOCATION OF ALL EXISTING UTILITIES PRIOR TO COMMENCING CONSTRUCTION. PROPOSED DRIVEWAY CUTS MAY REQUIRE EXISTING UTILITY FACILITIES TO BE LOWERED AND/OR RELOCATED IN ORDER TO MAINTAIN MINIMUM STANDARDS OF COVER / VERTICAL SEPARATION, INCLUDING WATER, GAS, POWER, AND TELECOM.

**NOTE**

REFER TO ARCHITECTURAL & FOUNDATION PLANS FOR ALL BUILDING DIMENSIONS.

**ADA DECTABLE WARNING NOTE**

ALL TRUNCATED DOME PLATES SHALL BE BLACK IN COLOR

**TOWN OF MCCORDSVILLE STANDARDS**

CONTRACTOR TO CONSTRUCT ALL APPLICABLE SITE IMPROVEMENTS TO THE TOWN OF MCCORDSVILLE CURRENT STANDARDS PER THE ATTACHED STANDARD DETAIL SHEETS.

REVISION RECORD				
REV	DATE	DESCRIPTION	DES BY	APP BY
1	11/04/25	TAC REVIEW; BLDG. BASE / D.T. PLANTINGS	BSC	BSC

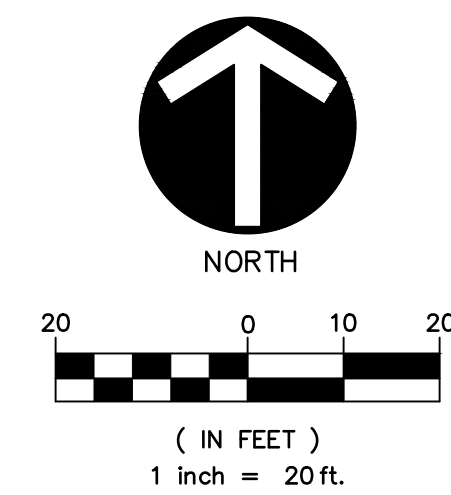

**DEVELOPMENT SUMMARY**

PROPOSED USE: RETAIL-SMALL BUILDING(S) GROSS SQUARE FOOTAGE = 3,200± S.F. TOTAL SITE AREA = 5.69± AC. OPEN SPACE AREA = xxxx± Ac. (xx% of TOTAL LOT AREA) IMPERVIOUS AREA COVERAGE = xxxx± Ac. (xx%) CURRENT ZONING = VILLAGES AT BROOKSIDE PUD-AMENDMENT  
 PARKING SPACES PROVIDED = 33 PARKING SPACES REQUIRED = 22 (1 PER EMPLOYEE + 1 / 3 SEATS) TENANT SEATING = 42; 8 EMPLOYEES  
 ANTICIPATED CONSTRUCTION START/END DATE: JANUARY, 2026 / JULY 2026

**LEGEND:**

- R/W PROPERTY BOUNDARY OR R/W (REFER TO ALTA/NSPS SURVEY)
- SAWCUT LIMITS (WHERE NECESSARY-FOR UTILITY INSTALLATION)
- # OF PARKING SPACES IN ROW
- LIGHT DUTY ASPHALT PAVEMENT. SEE DETAIL 03/C7.0  
1.5" - 110#/SYD. HMA BITUMINOUS SURFACE 9.5mm ON 2" - 330#/SYD. HMA BITUMINOUS INTERMEDIATE 19.0mm ON 6" COMPACTED AGGREGATE #53 BASE ON ENGR. APPROVED GEOGRID\*\* ON COMPACTED SUBGRADE OR TREATED SUBGRADE. \*\* DESIGNATES CONSTRUCTION ALTERNATE IF DETERMINED IS NEEDED AFTER RESULTS OF SUBGRADE PROOF ROLL
- HEAVY DUTY ASPHALT PAVEMENT. SEE DETAIL 02/C7.0  
1.5" - 110#/SYD. HMA BITUMINOUS SURFACE 9.5mm ON 3" - 330#/SYD. HMA BITUMINOUS INTERMEDIATE 19.0mm ON 6" COMPACTED AGGREGATE #53 BASE ON ENGR. APPROVED GEOGRID\*\* ON COMPACTED SUBGRADE OR TREATED SUBGRADE. \*\* DESIGNATES CONSTRUCTION ALTERNATE IF DETERMINED IS NEEDED AFTER RESULTS OF SUBGRADE PROOF ROLL
- PROPOSED CONCRETE PAVEMENT. SEE DETAIL 01/C7.0  
8" CONC. PAVEMENT ON SUBGRADE TREATMENT TYPE II - (6" COMPACTED COARSE AGGREGATE INDOT #53 STONE) ON COMPACTED SUBGRADE
- PROPOSED CONCRETE SIDEWALK
- PROPOSED PAINTED DIAGONAL STRIPED ISLAND

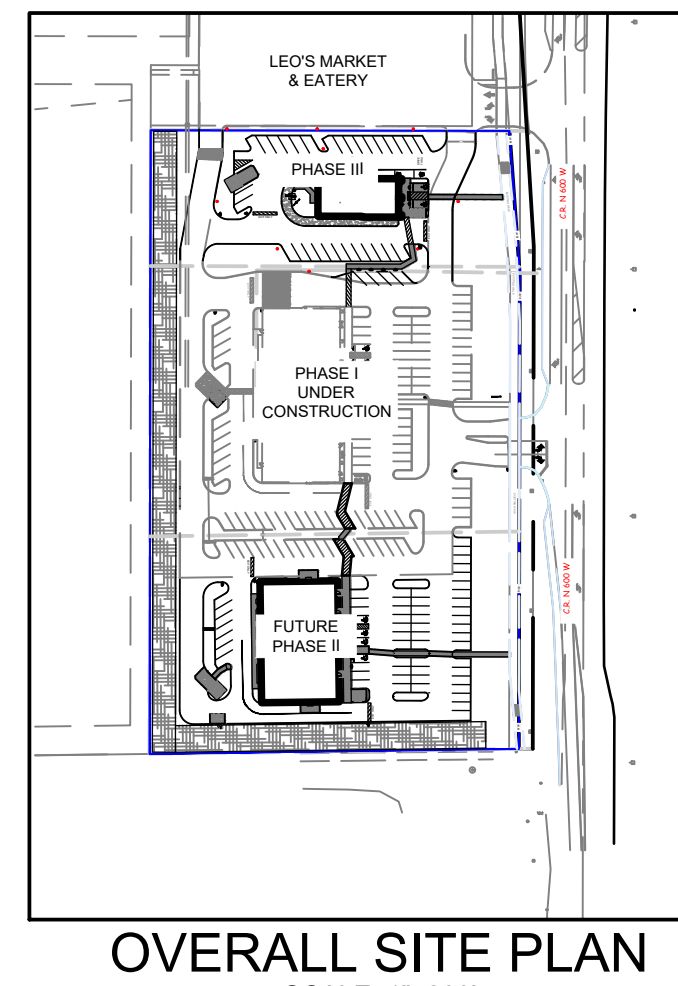

OVERALL SITE PLAN  
SCALE: 1"=200'

**LEO'S MARKET & EATERY**

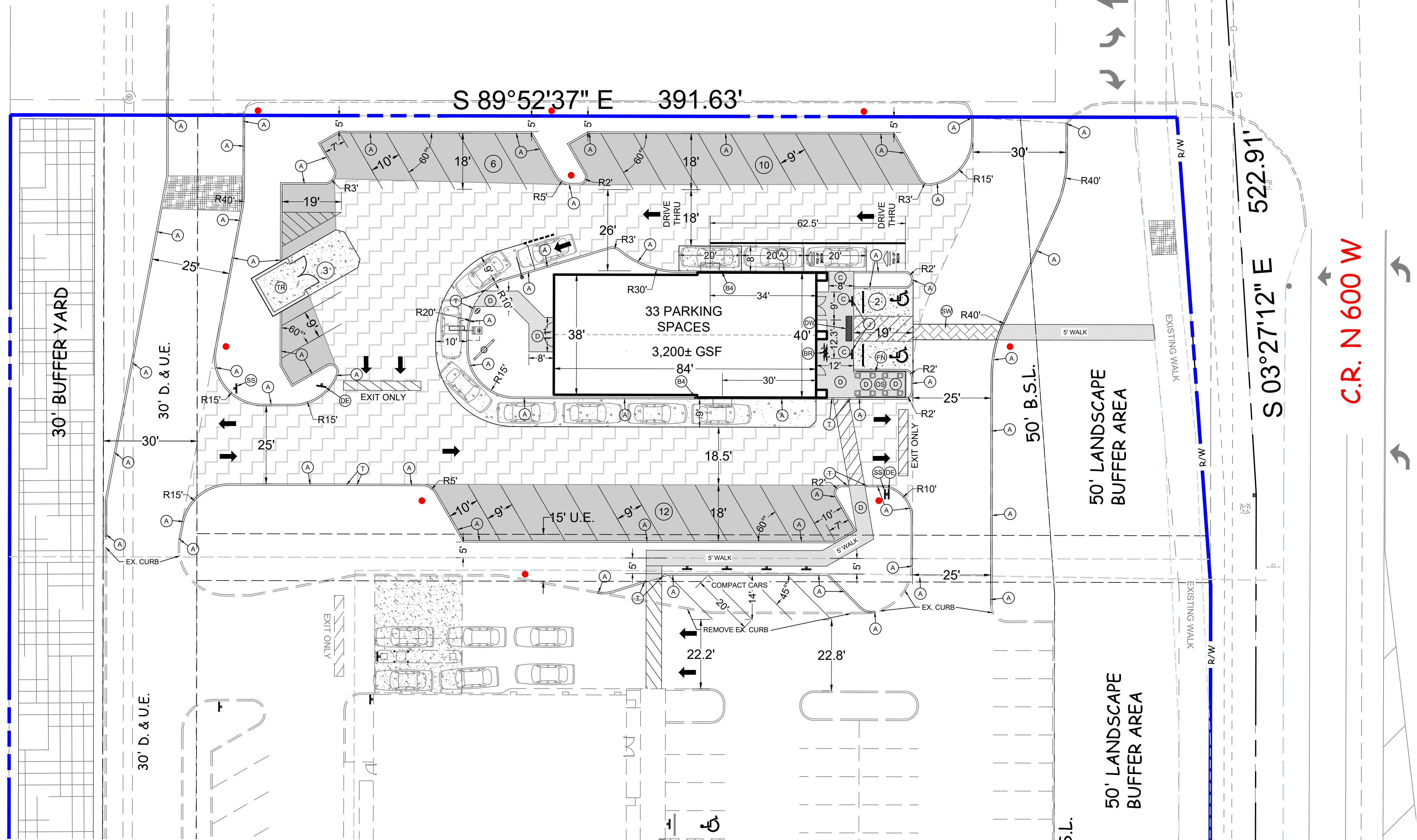

**PLAN NOTES:**

- (A) 6" STRAIGHT CONC. CURB. SEE DETAIL 05/C7.0
- (A1) 1'-2" WIDE STRAIGHT CONC. CURB/WALK ALONG SOUTH BUILDING WALL
- (A2) 2'± WIDE STRAIGHT CONC. CURB/WALK ALONG NORTH BUILDING WALL
- (B) 4" OR 6" CONC. FILLED BOLLARD PAINTED GLOSS BLACK AS DENOTED SEE DETAIL 17/C7.0
- (BR) DERO HOOP BIKE RACK HR-FE-EPX BLACK
- (C) COMBINED CURB & WALK. SEE DETAIL 04/C7.0
- (D) CONCRETE SIDEWALK. SEE DETAIL 07/C7.2
- (E) "DO NOT ENTER" SIGN, R5-1 (30"x30")
- (F) DETECTABLE WARNING STRIP (COLOR BLACK). SEE DETAIL 06/C7.0
- (FL) FLUSH WITH PAVEMENT
- (G) TYPICAL PARKING SPACE MARKING. SEE DETAILS 08 & 10/C7.0
- (H) TRAFFIC SIGNAGE. SEE DETAIL 15 & 16/C7.0
- (I) PRECAST CONC. WHEEL STOPS (QTY 2)
- (J) TAPER CURB FLUSH INTO WALK/PAVEMENT
- (K) TRASH ENCLOSURE. REFER TO ARCH. PLANS FOR DETAILS
- (L) STOP SIGN, R1-1 (30"x30")
- (M) COLORED CONCRETE PAVEMENT (MATCH LEO'S) FOR PEDESTRIAN WALKWAYS: 6" CONC W/ WWF (1.6x1.6) OR F.R.; ON 6" COMP. #53 STONE; ON COMPACTED SUBGRADE
- (N) "RIGHT TURN ONLY" SIGN
- (O) OUTDOOR SEATING AREA. REFER TO ARCH. PLANS FOR DETAILS
- (P) OUTDOOR SEATING FENCING. REFER TO ARCH. PLANS FOR DETAILS

**SITE LAYOUT NOTES**

1. ALL CONSTRUCTION METHODS AND MATERIALS MUST CONFORM TO CURRENT STANDARDS AND SPECIFICATIONS OF THE FEDERAL, STATE, COUNTY, CITY, OR LOCAL REQUIREMENTS, WHICHEVER HAS JURISDICTION.
2. ALL PARKING STRIPES ARE TO BE 4" PAINTED WHITE. UNLESS OTHERWISE NOTED ON THE PLANS, DETAILS, OR SPECIFICATIONS.
3. ALL DIMENSIONS ARE TO EDGE OF PAVEMENT, FACE OF CURB/SIDEWALK, RADI TO BACK OF CURB, WHERE APPLICABLE.
4. ALL DIMENSIONS ARE TO OUTSIDE FACE OF BRICK OR FACING MATERIAL, WHERE APPLICABLE. CONTRACTOR TO REFER TO ARCHITECTURAL DRAWINGS FOR ACTUAL BUILDING DIMENSIONS.
5. THE CONTRACTOR SHALL VERIFY ALL DIMENSIONS AND ELEVATIONS IN THE FIELD PRIOR TO THE START OF CONSTRUCTION. THE CONTRACTOR SHALL BE RESPONSIBLE FOR ALL FIELD DIMENSIONS AND ELEVATIONS DURING THE ENTIRE CONSTRUCTION SCHEDULE. IF ANY DISCREPANCIES ARE FOUND IN THESE PLANS FROM ACTUAL FIELD DIMENSIONS, THE CONTRACTOR SHALL CONTACT THE ENGINEER IMMEDIATELY.
6. PROVIDE SMOOTH TRANSITION FROM NEWLY PAVED AREAS TO EXISTING AREAS AS NECESSARY. ALL AREAS WHERE PROPOSED PAVEMENT MEETS EXISTING PAVEMENT, THE EXISTING EDGE OF PAVEMENT SHALL BE FREE OF ALL LOOSE DEBRIS. THE EDGE OF EXISTING ASPHALT PAVEMENT SHALL BE PROPERLY SEALED WITH A TACK COAT MATERIAL IN ALL AREAS WHERE NEW ASPHALT PAVEMENT IS INDICATED TO JOIN EXISTING.
7. ALL EXCAVATED AREAS TO BE SEEDDED AND/OR SODDED AFTER FINISH GRADING UNLESS OTHERWISE NOTED. ALL NEWLY SODDED/SEEDDED AREAS SHALL HAVE A MINIMUM OF 4" OF TOPSOIL. HOLD SOIL DOWN 1" FROM PAVEMENT ELEVATION. CONTRACTOR TO SUPPLY STRAW MULCH WHERE GRASS SEED HAS BEEN PLANTED.
8. RESURFACE OR RECONSTRUCT AT LEAST TO ORIGINAL CONDITIONS ALL AREAS WHERE TRAFFIC BY CONTRACTORS, SUBCONTRACTORS OR SUPPLIERS HAVE DAMAGED EXISTING PAVEMENT, LAWNS OR OTHER IMPROVEMENTS DURING CONSTRUCTION. AFTER CONSTRUCTION WORK IS COMPLETE.
9. ALL UTILITY TRENCHES WITHIN 5 FEET OF PAVEMENT SHALL BE COMPLETELY BACKFILLED WITH GRANULAR BACKFILL.
10. ALL RADII INDICATED SHALL BE CONSTRUCTED AS CIRCULAR ARCS.
11. ALL PARKING SPACE DIMENSIONS ARE TO BE 9' WIDE BY 19' DEEP UNLESS OTHERWISE SPECIFIED.

**DEVELOPER:**  
BDC REALTY GROUP, LLC  
6274 SOUTH FOX CHASE  
PENDLETON, INDIANA 46064  
ATTN: DAVE CRAVENS  
(765) 635-5559

**ENGINEER:**  
CIVIL SITE GROUP, INC.  
718 ADAMS STREET  
CARMEL, INDIANA 46032  
(317) 810-1677

**SURVEYOR:**  
CROSSROAD ENGINEERS  
3417 Sherman Drive  
Beech Grove, IN 46107  
ATTN: G.W. Charles, PE, PS  
(317) 780-1555

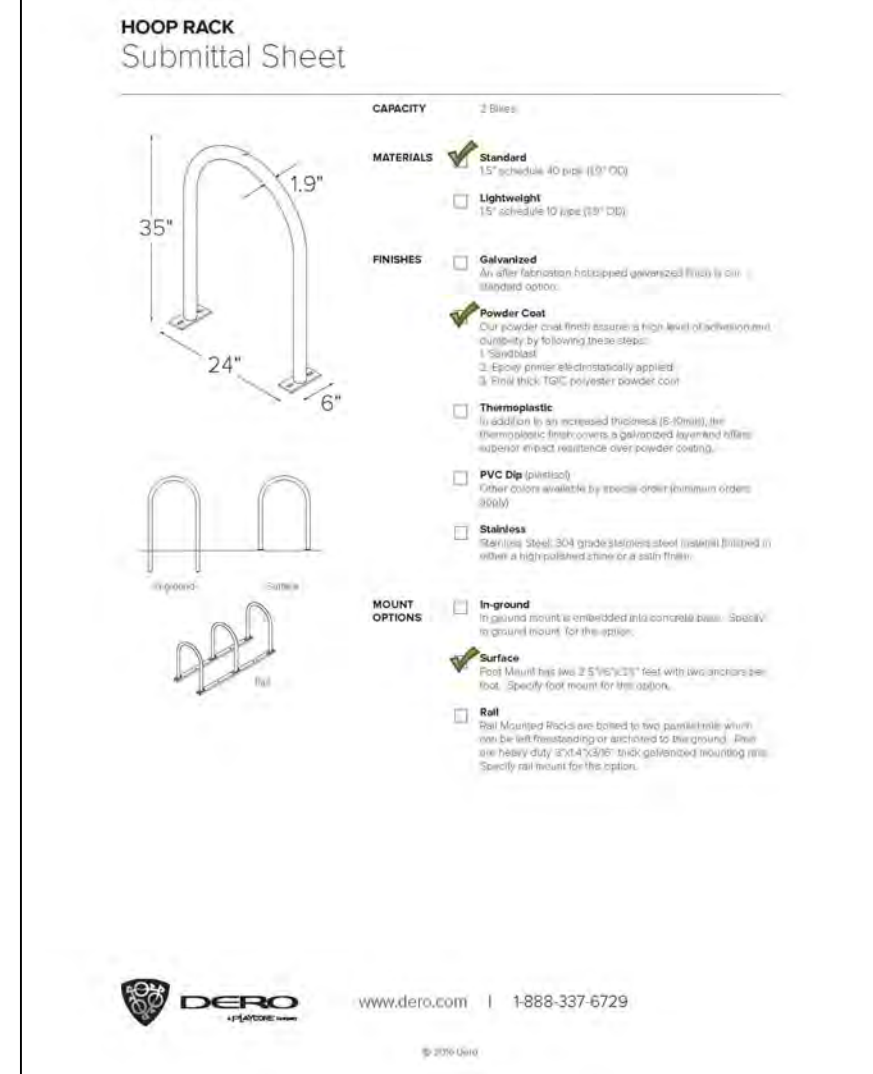

**BDC REALTY GROUP, LLC**  
6274 S FOX CHASE  
PENDLETON, IN 46064

**CIVIL SITE GROUP, INC.**  
718 Adams Street, Suite E  
Carmel, Indiana 46032  
Ph: (317) 810-1677



DWN BY: BSC  
CHKD. BY: BSC  
SCALE: 1" = 20'  
DATE: 10/02/25

**THE SHOPS at BROOKSIDE - BLOCK A**  
CR 600 W  
MCCORDSVILLE, IN 46055

**SITE PLAN**  
PHASE III - NORTH BUILDING

PROJECT NUMBER  
**BRG.008**

DRAWING NUMBER  
**C2.0**  
SHEET 2 OF 24



**CASTING NOTE**

STORM INLET CASTINGS TO REQUIRE A "NO DUMPING" MESSAGE PER THE TOWN OF MCCORDSVILLE STANDARDS.

**BENCHMARK**

SITE BENCHMARKS:  
(LOCATIONS SHOWN ON SURVEY)

TBM #400 CUT "X" ON WEST ANCHOR BOLT OF SIGNAL POLE, LOCATED IN SOUTHWEST QUAD OF "CR 900 N" AND "CR 600 W".

ELEV. = 850.90 (NAVD 88)

**TOPOGRAPHIC & BOUNDARY NOTE**

ALL EXISTING HORIZONTAL AND VERTICAL INFORMATION HAS BEEN SHOWN PER A TOPOGRAPHIC SURVEY DATED 03/11/2024 PREPARED BY CROSSROAD ENGINEER, P.C.; THEREFORE, CIVIL SITE GROUP, INC. CANNOT BE HELD RESPONSIBLE IF ACTUAL HORIZONTAL AND VERTICAL DATA IS DIFFERENT FROM THAT SHOWN ON THESE PLANS. CONTRACTOR IS RESPONSIBLE FOR FIELD VERIFICATION OF ALL EXISTING CONDITIONS PRIOR TO COMMENCING WITH CONSTRUCTION.

**FLOOD NOTE**

THIS LOT LIES ENTIRELY IN FLOOD HAZARD ZONE "X" AS SCALED FROM THE FLOOD INSURANCE RATE MAP (FIRM) FOR HANCOCK COUNTY, INDIANA, COMMUNITY NUMBER 180468, MAP NUMBER 18059C0016D, PANEL NUMBER 0016 D, DATED DECEMBER 4, 2007. REFERENCE NFIP FIRM MAP #18059C0016D, EFFECTIVE DATE: DECEMBER 4, 2007

**STORM SEWER SYSTEM NOTE**

ALL ON-SITE STORM SEWER INFRASTRUCTURE TO BE CONSTRUCTED WITH THIS PROJECT SHALL BE PRIVATELY OWNED AND MAINTAINED.

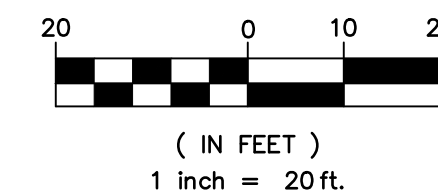
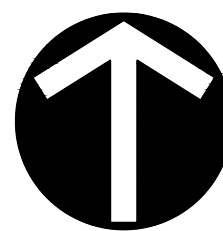

**REVISION RECORD**

REV	DATE	DESCRIPTION	DES BY	APP BY
1	11/04/25	TAC REVIEW; STORM SEWER; ROOF DRAINS	BSC	BSC

**GRADING & UTILITY NOTE**

CONTRACTOR TO VERIFY THE DEPTH AND LOCATION OF ALL EXISTING UTILITIES PRIOR TO COMMENCING CONSTRUCTION. PROPOSED DRIVEWAY CUTS MAY REQUIRE EXISTING UTILITY FACILITIES TO BE LOWERED AND/OR RELOCATED IN ORDER TO MAINTAIN MINIMUM STANDARDS OF COVER / VERTICAL SEPARATION, INCLUDING WATER, GAS, POWER, AND TELECOM.

**PLAN NOTES:**

- (R1) APPROX. 60± LF OF 8" PVC (SDR35 @ 1.0% MIN. SLOPE) ROOF DRAIN LEADER WITH RISERS, ADAPTERS FOR CONNECTIONS, BENDS, FITTINGS, & CLEANOUTS AT BENDS > 22.5' FOR ROOF CONNECTIONS; REDUCE TO 6" TO BLDG. DOWNSPOUTS
- (R2) APPROX. 33± LF OF 6" PVC (SDR35 @ 1.0% MIN. SLOPE) ROOF DRAIN LEADER WITH RISERS, ADAPTERS FOR CONNECTIONS, BENDS, FITTINGS, & CLEANOUTS AT BENDS > 22.5' FOR ROOF CONNECTIONS; REDUCE TO 6" TO BLDG. DOWNSPOUTS
- (FL) FLUSH WITH PAVEMENT

**DEVELOPER:**  
BDC REALTY GROUP, LLC  
6274 SOUTH FOX CHASE  
PENDLETON, INDIANA 46064  
ATTN: DAVE CRAVENS  
(765) 635-5559

**ENGINEER:**  
CIVIL SITE GROUP, INC.  
718 ADAMS STREET  
CARMEL, INDIANA 46032  
(317) 810-1677

**SURVEYOR:**  
CROSSROAD ENGINEERS  
3417 Sherman Drive  
Beech Grove, IN 46107  
ATTN: G.W. Charles, PE, PS  
(317) 780-1555

**LEGEND:**

- R/W PROPERTY BOUNDARY OR R/W (REFER TO ALTA/NSPS SURVEY)
- PROPOSED STORM SEWER
- PROPOSED INLET SUB-SURFACE DRAIN / ROOF DRAINS
- PROPOSED STORM STRUCTURE
- EX. UNDERGROUND STORM SEWER LINE
- PROPOSED SPOT ELEVATION
- PROPOSED TOP OF CURB ELEVATION
- PROPOSED PVMT ELEVATION
- ME MATCH EXISTING GRADE
- TC TOP OF CURB/STORM CASTING ELEVATION
- INV STORM SEWER INVERT ELEVATION
- 849 PROPOSED CONTOUR
- 850 EXISTING CONTOUR
- PROPOSED DRAINAGE SWALE
- EXISTING SITE OVERFLOW ROUTING

**GENERAL NOTES**

CONTRACTOR TO KEEP EXISTING PAVEMENT SURROUNDING THE SITE (CR N 600 W) "BROOM CLEAN" AND FREE OF SOIL OR AGGREGATE THAT MIGHT BE BROUGHT OFF-SITE.

DEPENDING ON THE CONSTRUCTION SEASON, MOISTURE CONTENT AND PROPERTIES OF THE SOILS ON SITE, CHEMICAL MODIFICATIONS AND/OR LIME STABILIZATION MAY BE REQUIRED. SEE SHEET C9.0 FOR SPECIFICATIONS.

ALL CONCRETE PIPE JOINTS SHALL BE CONTINUOUS O-RING RUBBER GASKET CONFORMING TO ASTM C 443

CONTRACTOR SHALL SUBMIT PRECAST STORM SEWER STRUCTURE SHOP DRAWINGS TO ENGINEER FOR REVIEW/APPROVAL PRIOR TO MANUFACTURING.

**GRADING NOTES**

1. ALL CONSTRUCTION METHODS AND MATERIALS MUST CONFORM TO CURRENT STANDARDS AND SPECIFICATIONS OF THE FEDERAL, STATE, COUNTY, CITY OR LOCAL REQUIREMENTS, WHICHEVER HAS JURISDICTION.
2. THE CONTRACTOR SHALL VERIFY ALL DIMENSIONS IN THE FIELD PRIOR TO STARTING CONSTRUCTION. THE CONTRACTOR SHALL BE RESPONSIBLE FOR ALL FIELD DIMENSIONS; IF ANY DISCREPANCIES ARE FOUND IN THESE PLANS FROM THE ACTUAL FIELD CONDITIONS, THE CONTRACTOR SHALL NOTIFY THE ENGINEER IMMEDIATELY.
3. THE EXCAVATING CONTRACTOR MUST TAKE PARTICULAR CARE WHEN EXCAVATING IN AND AROUND EXISTING UTILITY LINES AND EQUIPMENT. VERIFY COVER REQUIREMENTS BY UTILITY CONTRACTORS AND/OR UTILITY COMPANIES AS NOT TO CAUSE DAMAGE.
4. THE CONTRACTOR SHALL NOTIFY ALL UTILITY COMPANIES 72 HOURS BEFORE CONSTRUCTION IS TO START TO VERIFY IF ANY UTILITIES ARE PRESENT ON SITE. ALL VERIFICATIONS (LOCATION, SIZE AND DEPTH) SHALL BE MADE BY THE APPROPRIATE UTILITY COMPANIES. WHEN EXCAVATING IS AROUND OR OVER EXISTING UTILITIES, THE CONTRACTOR MUST NOTIFY THE UTILITY COMPANY SO A REPRESENTATIVE OF THAT UTILITY COMPANY CAN BE PRESENT TO INSTRUCT AND OBSERVE DURING CONSTRUCTION.
5. TRENCHES FOR ALL STORM DRAIN LINES SHALL BE BACKFILLED COMPLETELY WITH ENGINEERED GRANULAR MATERIAL IF WITHIN 5 FEET OF PAVEMENT.
6. AFTER STRIPPING TOPSOIL MATERIAL, PROOFROLL WITH A MEDIUM WEIGHT ROLLER TO DETERMINE LOCATIONS OF ANY POCKETS OF UNSUITABLE MATERIAL. THE NECESSITY FOR SUBGRANS AND/OR REMOVAL OF ANY UNSUITABLE MATERIAL WITHIN THE PROPOSED PARKING AREAS WILL BE DETERMINED AT THE TIME OF CONSTRUCTION.
7. PROVIDE POSITIVE DRAINAGE WITHOUT PONDING, IN ALL AREAS, AFTER INSTALLATION. CONTRACTOR TO TEST FOR, AND CORRECT, IF ANY, "BIRD BATH" CONDITIONS.
8. ALL PROPOSED SPOT ELEVATIONS ARE THE FINAL PAVEMENT AND FINAL GRADE ELEVATIONS.
9. SEE APPROPRIATE DETAILS TO DETERMINE SUBGRADE ELEVATIONS BELOW FINISH GRADE ELEVATIONS INDICATED.
10. FLOW LINE ELEVATIONS GIVEN AT END OF CONCRETE END SECTIONS.
11. SIDEWALK AGAINST BUILDING SHALL SLOPE AWAY FROM BUILDING AT 1.04% SLOPE MIN.

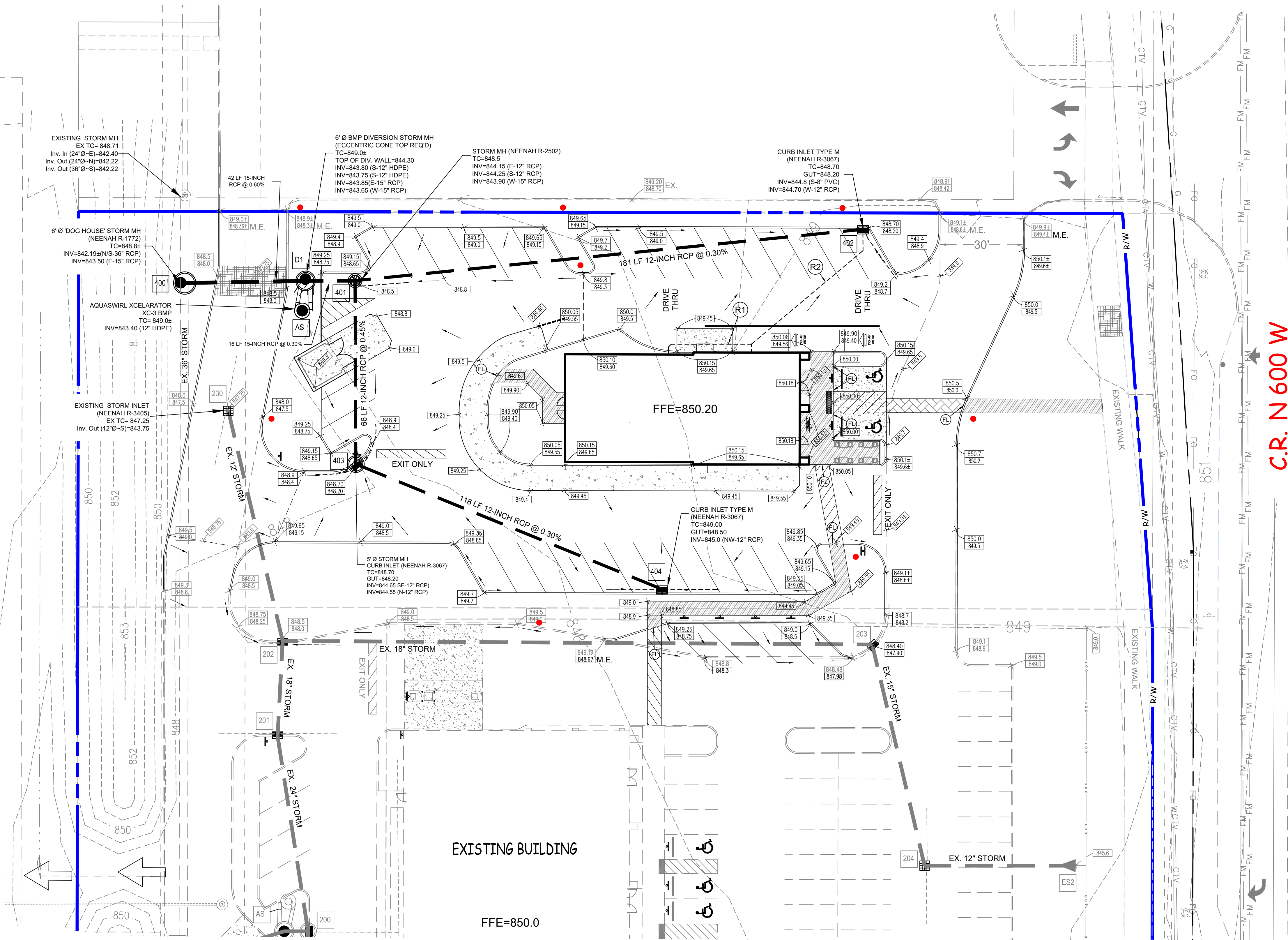

BDC REALTY GROUP, LLC  
6274 S FOX CHASE  
PENDLETON, IN 46064

CIVIL SITE GROUP, INC.  
718 Adams Street, Suite E  
Carmel, Indiana 46032  
Ph: (317) 810-1677

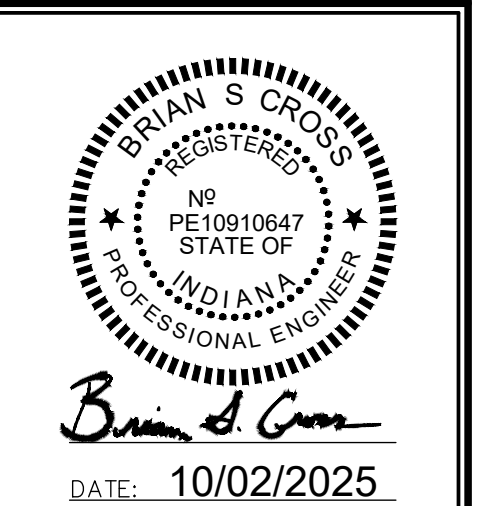

DWN BY: BSC  
CHKD. BY: BSC  
SCALE: 1" = 20'  
DATE: 10/02/25

THE SHOPS at BROOKSIDE - BLOCK A  
CR 600 W  
MCCORDSVILLE, IN 46055

GRADING & DRAINAGE PLAN  
PHASE III - NORTH BUILDING

PROJECT NUMBER  
BRG.008

DRAWING NUMBER  
**C3.0**  
SHEET 3 OF 24



## SOILS DESCRIPTIONS & LIMITATIONS

- Crosby Silt Loam (YcuA - 32.7% Site)** The Crosby series consists of very deep, somewhat poorly drained soils that are moderately deep to dense till on till plains. These soils formed in loamy till that can be capped with up to 22 inches of loess or silty material. Permeability is moderate or moderately slow in and above the argillic horizon and slow or very slow below the argillic horizon. Slope ranges from 0 to 6 percent. Subject soil does not present any foreseeable limitations to the proposed development.
- Brookston Silty Clay Loam (YbvA - 67.3% Site)** The Brookston series consists of very deep, poorly drained soils formed in up to 20 inches of silty material and the underlying loamy till in depressions on till plains and moraines. Permeability is moderate in the subsoil and moderately slow in the underlying material. Slope ranges from 0 to 3 percent. Subject soil does not present any foreseeable limitations to the proposed development. Given that this soil typically shows high moisture content and is a hydric soil, permeability may be moderate, soil chemical modifications (i.e. lime stabilization) may likely be required.

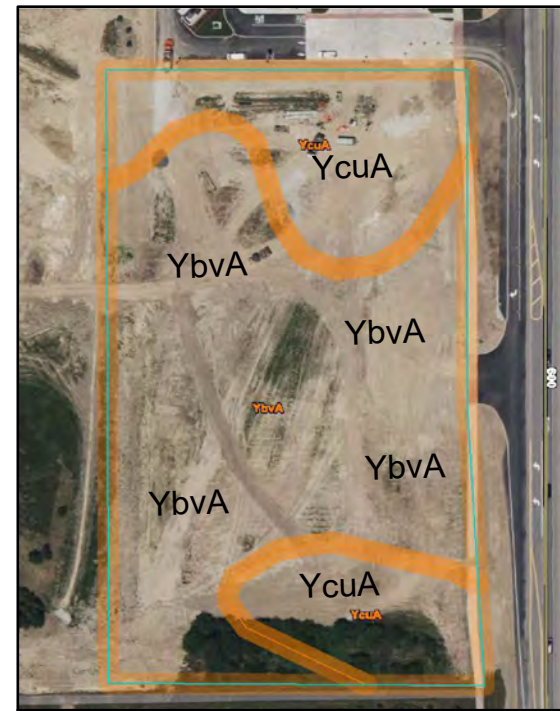

SOILS MAP  
SCALE: 1" = 200'



### CASTING NOTE

STORM INLET CASTINGS TO REQUIRE A "NO DUMPING" MESSAGE PER THE TOWN OF PENDLETON STANDARDS.

### FLOOD NOTE

THIS LOT LIES ENTIRELY IN FLOOD HAZARD ZONE "X" AS SCALED FROM THE FLOOD INSURANCE RATE MAP (FIRM) FOR HANCOCK COUNTY, INDIANA. COMMUNITY NUMBER 180468, MAP NUMBER 18059C0016D, PANEL NUMBER 0016 D, DATED DECEMBER 4, 2007. REFERENCE NFIP FIRM MAP #18059C0016D, EFFECTIVE DATE: DECEMBER 4, 2007

### SWPP TRAINED INDIVIDUAL:

Self-inspections - A trained individual shall perform visual inspections of the project site. A trained individual is an individual who is trained and experienced in the principles of stormwater management, including erosion and sediment control as is demonstrated by completion of coursework, state registration, professional certification, or annual training that enable the individual to make judgments regarding stormwater management, treatment, and monitoring.

- The frequency of self-inspections are:
  - At least once every work week;
  - Within twenty-four (24) hours after qualifying precipitation event, which is precipitation accumulation equal to, or greater than, one-half (0.50) inch of rainfall within a 24-hour period. Inspections that were conducted twenty-four (24) hours prior to a qualifying precipitation event meet this requirement.
  - If there are multiple qualifying precipitation events occur during the week no more than three (3) inspections are required within that week.

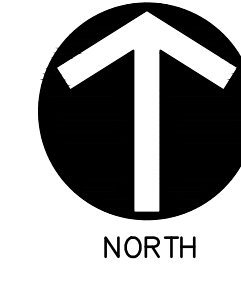

### DEVELOPMENT SUMMARY

TOTAL SITE AREA = 5.69± ACRES  
TOTAL DISTURBED AREA = 1.0± ACRES

### REVISION RECORD

REV	DATE	DESCRIPTION	DES BY	APP BY
1	11/04/25	TAC REVIEW REVISIONS	BSC	BSC

### TOPOGRAPHIC & BOUNDARY NOTE

ALL EXISTING HORIZONTAL AND VERTICAL INFORMATION HAS BEEN SHOWN PER A TOPOGRAPHIC SURVEY DATED 03/11/2024 PREPARED BY CROSSROAD ENGINEER, P.C.; THEREFORE, CIVIL SITE GROUP, INC. CANNOT BE HELD RESPONSIBLE IF ACTUAL HORIZONTAL AND VERTICAL DATA IS DIFFERENT FROM THAT SHOWN ON THESE PLANS. CONTRACTOR IS RESPONSIBLE FOR FIELD VERIFICATION OF ALL EXISTING CONDITIONS PRIOR TO COMMENCING WITH CONSTRUCTION.

### TOWN OF MCCORDSVILLE STANDARDS

CONTRACTOR TO CONSTRUCT ALL APPLICABLE SITE IMPROVEMENTS TO THE TOWN OF MCCORDSVILLE CURRENT STANDARDS PER THE ATTACHED STANDARD DETAIL SHEETS.

### DEWATERING DISCHARGE

ALL DEWATERING PUMPING SHALL BE DISCHARGED INTO AN APPROVED FILTER BAG BEFORE RELEASING INTO THE EXISTING STORM SEWER SYSTEM AND/OR R/W SWALE.

### GENERAL NOTES

- CONTRACTOR TO SCHEDULE A PRE-CONSTRUCTION MEETING WITH THE TOWN OF MCCORDSVILLE AND/OR HANCOCK COUNTY SOIL & WATER CONSERVATION DISTRICT PRIOR TO COMMENCING WITH CONSTRUCTION.
- TEMPORARY TRAFFIC CONTROL DURING CONSTRUCTION TO CONFORM TO APPLICABLE LOCAL AND STATE STANDARDS.
- ALL CONSTRUCTION ACTIVITY ON THIS SITE TO BE PERFORMED IN COMPLIANCE WITH APPLICABLE O.S.H.A. STANDARDS FOR WORKER SAFETY.
- IT SHALL BE THE CONTRACTORS RESPONSIBILITY TO FIELD VERIFY ALL UTILITY LOCATIONS BEFORE CONSTRUCTION BEGINS.
- IT SHALL BE THE CONTRACTORS RESPONSIBILITY TO FIELD VERIFY ALL EXISTING ELEVATIONS BEFORE CONSTRUCTION BEGINS.

### ADDITIONAL EROSION CONTROL MEASURES MAY BE REQUIRED IN THE FIELD BY THE INSPECTOR

#### EROSION CONTROL NOTES

- ALL CONSTRUCTION METHODS AND MATERIALS MUST CONFORM TO CURRENT STANDARDS AND SPECIFICATIONS OF THE FEDERAL, STATE, COUNTY, CITY OR LOCAL REQUIREMENTS, WHICHEVER HAS JURISDICTION.
- LAND ALTERATION WHICH STRIPS THE LAND OF VEGETATION, INCLUDING REGRADING, SHALL BE DONE IN A WAY THAT WILL MINIMIZE EROSION.
- THIS PLAN SHALL NOT BE CONSIDERED ALL INCLUSIVE AS THE CONTRACTOR SHALL TAKE ALL NECESSARY PRECAUTIONS TO PREVENT SOIL SEDIMENT FROM LEAVING THE SITE. ADDITIONAL EROSION AND SEDIMENT CONTROL MEASURES WILL BE INSTALLED IF DEEMED NECESSARY BY ON-SITE INSPECTION.
- SEDIMENT LADEN WATER SHALL BE OBTAINED BY EROSION CONTROL PRACTICES AS NEEDED TO MINIMIZE SEDIMENTATION IN THE RECEIVING STREAM. NO STORM WATER SHALL BE DISCHARGED FROM THE SITE IN A MANNER THAT CAUSES EROSION AT THE POINT OF DISCHARGE.
- WASTES AND UNUSED BUILDING MATERIALS SHALL NOT BE ALLOWED TO BE CARRIED FROM THE SITE BY STORMWATER RUNOFF. PROPER DISPOSAL OF ALL WASTES AND UNUSED BUILDING MATERIALS IS REQUIRED.
- SEDIMENT BEING TRACED ONTO PUBLIC OR PRIVATE ROADWAYS SHALL BE MINIMIZED. CLEARING OF ACCUMULATED SEDIMENT SHALL NOT INCLUDE FLUSHING WITH WATER. CLEARED SEDIMENT SHALL BE RETURNED TO THE SITE FOR DISPOSAL.
- SOIL WHICH HAS ACCUMULATED NEXT TO EROSION CONTROL DEVICES SHALL BE COLLECTED AND REDISTRIBUTED ON SITE AFTER EACH RAINFALL EVENT, AND AT LEAST ONCE A WEEK.
- IF INSTALLATION OF STORM DRAINAGE SYSTEM SHOULD BE INTERRUPTED BY WEATHER OR NIGHTFALL, THE PIPE ENDS SHALL BE COVERED WITH FILTER FABRIC.
- ALL EXISTING STRUCTURES, FENCING, TREES AND ETC., WITHIN CONSTRUCTION AREA SHALL BE REMOVED AND DISPOSED OF OFF SITE. BURNING IS NOT ALLOWED ON-SITE.
- SCHEDULE OF EARTHWORK ACTIVITIES:
  - THE DURATION OF TIME WHICH AN AREA REMAINS EXPOSED SHALL BE KEPT TO A PRACTICAL MINIMUM. THE AREA SHALL BE STABILIZED SOON AS POSSIBLE. TEMPORARY VEGETATION OR MULCHING SHALL BE USED TO PROTECT EXPOSED AREAS IF PERMANENT VEGETATION CANNOT BE SEEDING WITHIN 14 DAYS OR ACTIVITY CEASES FOR MORE THAN 21 DAYS OR AS DIRECTED BY THE ENGINEER.
  - TOPSOIL REPLACEMENT SHALL TAKE PLACE FROM MARCH 1 TO OCTOBER 31. STOCKPILE TOPSOIL AT ALL OTHER TIME OF THE YEAR. PERMANENT AND FINAL VEGETATION AND STRUCTURAL EROSION CONTROL DEVICES SHALL BE INSTALLED WITHIN SEVEN (7) DAYS AFTER FINAL GRADING OR AS SOON AS POSSIBLE.

### MULCHING NOTE

WHERE REQUIRED, CRIMPED/ANCHORED MULCH OR MULCH WITH A TACKING AGENT SHALL BE USED. THE APPLICATION RATE SHOULD MEET GUIDELINES PER PRACTICE 5.15 OF THE INDIANA HANDBOOK FOR EROSION CONTROL IN DEVELOPING AREAS.

### STREET EROSION NOTE

THERE SHALL BE NO DIRT, DEBRIS, OR STORAGE OF MATERIALS IN THE SURROUNDING STREETS DURING THE CONSTRUCTION PROCESS.

### EROSION CONTROL CONTACT

DAVE CRAVENS  
BDC REALTY GROUP, LLC  
6274 SOUTH FOX CHASE  
PENDLETON, INDIANA 46064  
(765) 635-5559

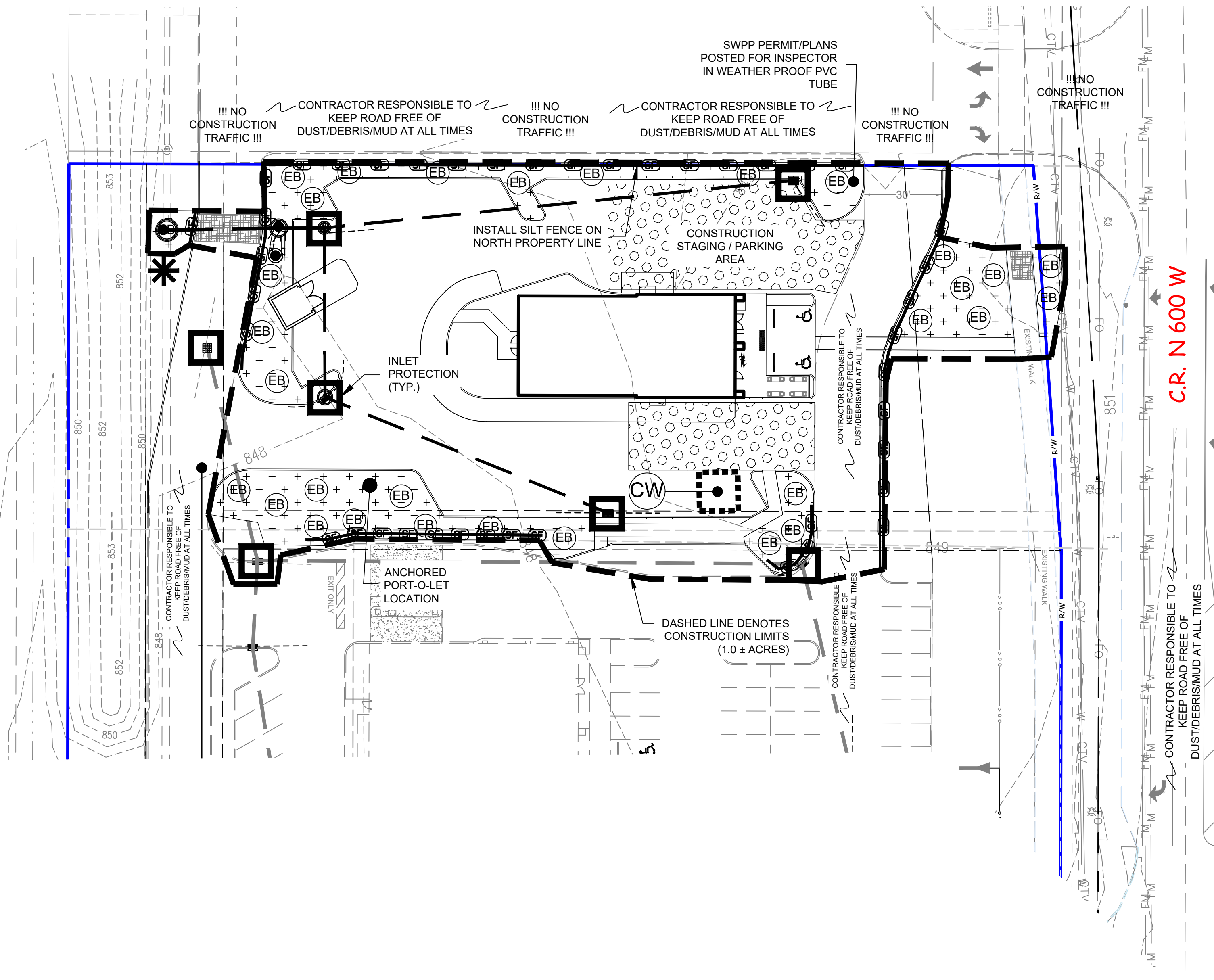

- LEGEND:**
- R/W (REFER TO ALTA/NSPS SURVEY)
  - PROPOSED STORM SEWER
  - PROPOSED SUB-SURFACE ROOF DRAIN
  - PROPOSED STORM STRUCTURE
  - EX. UNDERGROUND STORM SEWER LINE
  - PROPOSED CONTOUR
  - EXISTING CONTOUR
  - PROPOSED DRAINAGE SWALE
  - APPROX. CONSTRUCTION LIMITS
  - Check Dam/Sediment Filter - Pond Outlet Protection & Existing Road Culverts (Rock Check Dam). SEE DETAIL 04/C4.1
  - PROPOSED SILT FENCE-Typical in all areas where sediment could leave the site. SEE DETAIL 06/C4.1
  - PERMANENT SEEDING WITH STRAW MULCH - TYPICAL AFTER FINAL GRADING IS COMPLETED.
  - PROPOSED EROSION CONTROL BLANKET SEE DETAIL 05/C4.1
  - TEMPORARY SEEDING WITH STRAW MULCH - TYPICAL WHERE CONSTRUCTION ACTIVITIES WILL REMAIN IDLE FOR A PERIOD OF 10 DAYS OR MORE.
  - Point where stormwater will leave the site.
  - Inlet Protection FlexStorm Baskets to be utilized in paved areas. SEE DETAIL ON SHEET C4.1
  - PROPOSED TEMPORARY CONSTRUCTION ENTRANCE SEE DETAIL 03/C4.1

NOTE: INSTALL TEMPORARY SEEDING AFTER A SPECIFIC STAGE OF CONSTRUCTION HAS BEEN COMPLETED (TEMPORARY OR FINAL) WHERE AREAS WILL BE IDLE OF CONSTRUCTION ACTIVITIES FOR A PERIOD OF 7 DAYS OR MORE.

BDC REALTY GROUP, LLC  
6274 S FOX CHASE  
PENDLETON, IN 46064

CIVIL SITE GROUP, INC.  
718 Adams Street, Suite E  
Carmel, Indiana 46032  
Ph: (317) 810-1677

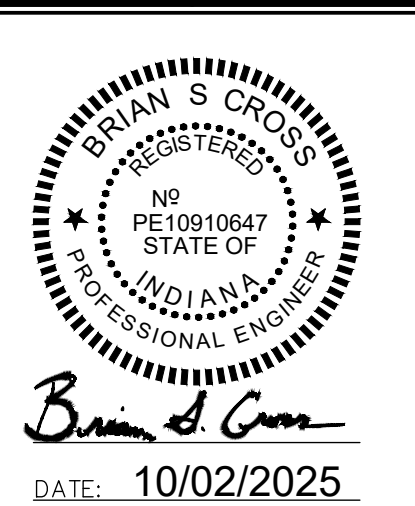

DWN BY: BSC  
CHKD. BY: BSC  
SCALE: 1" = 30'  
DATE: 10/02/25

THE SHOPS at BROOKSIDE - BLOCK A  
CR 600 W  
MCCORDSVILLE, IN 46055

STORMWATER POLLUTION PREVENTION PLAN  
PHASE III - NORTH BUILDING

PROJECT NUMBER  
BRG.008

DRAWING NUMBER  
**C4.0**  
SHEET 5 OF 24

**FERTILIZER NOTE**

DO NOT USE PHOSPHOROUS CONTAINING FERTILIZERS UNLESS SOIL TESTS SHOW A PHOSPHOROUS DEFICIENCY.

**SEEDBED PREPARATION**

APPLY LIME TO RAISE THE pH TO THE LEVEL NEEDED FOR SPECIES BEING SEED. APPLY 23 POUNDS OF 12-12-12 ANALYSIS FERTILIZER (OR EQUIVALENT) PER 1000 SQ. FT. (APPROXIMATELY 1000 POUNDS PER ACRE) OR FERTILIZE ACCORDING TO TEST. APPLICATION OF 150 LBS. OF AMMONIUM NITRATE ON AREAS LOW IN ORGANIC MATTER AND FERTILITY WILL GREATLY ENHANCE VEGETATIVE GROWTH.

WORK THE FERTILIZER AND LIME INTO THE SOIL TO A DEPTH OF 2-3 INCHES WITH A HARROW, DISK OR RAKE OPERATED ACROSS THE SLOPE AS MUCH AS POSSIBLE.

**SEEDING**

SELECT A SEED MIXTURE BASED ON PROJECTED USE OF THE AREA (SEE PERMANENT SEED MIXTURE CHART). WHILE CONSIDERING BEST SEEDING DATES. IF PERMANENT SEEDING IS NOT PERMITTED USE TEMPORARY SEEDING UNTIL PERMANENT SEEDING CAN BE APPLIED. IF TOLERANCES ARE A PROBLEM, SUCH AS SALT TOLERANCE OF SEEDINGS ADJACENT TO STREETS AND HIGHWAYS, SEE SEED TOLERANCE CHART.

SPECIES	SOIL CONDITION			SHADE TOLERANCE	CLOSE MOWING TO 2-3 1/2 INCHES	TRAMPING TOLERANCE	FERTILITY NEEDS	WINTER HARDINESS	FLOODING TOLERANCE (DAYS)	MATURE HEIGHT (INCHES)	EMERGENCE TIME (DAYS)	SOIL TOLERANCE	
	WET	NORM	DRY									GEN.	SOIL SPRAY
CREeping RED FESCUE FESTUCA RUBRA	2	1	2	1	1	1	MED.	1	20-25	12-18	7-21		S
KENTUCKY BLUEGRASS POA PRATENSIS	2	1	2	1	1	1	MED.	1	20-35	12-18	10-20		MT
TALL FESCUE FESTUCA L. ARUNDINACEA	2	1	1	1	1	1	LOW	1	24-35	24-36	5-14		T
PERENNIAL RYEGRASS LOLLUM PERENNE	2	1	2	-	1	2	MED. HIGH	2	15-20	12-18	5-10		MT
CROWN VETCH CORONILLA VARLA	-	1	1	-	-	-	LOW	1	5-10	24	14-21		T
RED CLOVER TRIFOLIUM PROTENSE	-	1	-	-	-	-	MED.	1	7-10	18	5-10	S	S

**RANKING:**  
1 GOOD  
2 MEDIUM  
- NOT TOLERANT

**SALT TOLERANCE (TO BOTH SOIL SALTS & SPRAY)**

T TOLERANCE  
MT MEDIUM TOLERANCE  
S SLIGHT TOLERANCE

**SEED TOLERANCE**

**FERTILIZER NOTE**

DO NOT USE PHOSPHOROUS CONTAINING FERTILIZERS UNLESS SOIL TESTS SHOW A PHOSPHOROUS DEFICIENCY.

SPECIES	SEEDING RATE		SUITABLE pH	SITE SUITABILITY*		
	LBS/ACRE	LBS/1000 SQ. FT.		DROUGHTY	WELL DRAINED	WET
<b>LEVEL AND SLOPING, OPEN AREAS</b>						
1. TALL FESCUE	35	.8	5.5-8.3	2	1	2
2. TALL FESCUE	25	.6	5.5-8.3		1	
3. RED CLOVER	5	.12				
3. KENTUCKY BLUEGRASS	15	.4	5.8-7.5	2	1	
3. CREeping RED FESCUE	15	.4				
<b>STEEP BANKS AND CUTS</b>						
4. TALL FESCUE	15	.4	5.8-7.5	2	1	2
5. KENTUCKY BLUEGRASS	25	.6				
5. TALL FESCUE	35	.8	5.5-8.3	2	1	
5. EMERALD CROWN VETCH**	10	.25				
<b>LAWNS AND HIGH MAINTENANCE AREAS</b>						
6. KENTUCKY BLUEGRASS	40	.9	5.8-7.5	2	1	
6. CREeping RED FESCUE	40	.9				
7. PERENNIAL RYEGRASS	170	4.0	5.0-7.5		1	
7. TALL FESCUE	170	4.0	5.5-8.3	2	1	2

\* 1 - PREFERRED 2 - WILL TOLERATE \*\* INOCULATE WITH SPECIFIC INOCULANT.

**SEED TOLERANCE CHART**

**SEEDING DETAIL**

**REVISION RECORD**

REV	DATE	DESCRIPTION	DES BY	APP BY

**TEMPORARY SEEDING DATES**

	JAN	FEB	MAR	APR	MAY	JUN	JUL	AUG	SEP	OCT	NOV	DEC
WHEAT OR RYE												
OATS												
ANNUAL RYEGRASS												

**PERMANENT SEEDING DATES**

	JAN	FEB	MAR	APR	MAY	JUN	JUL	AUG	SEP	OCT	NOV	DEC
NON-IRRIGATED*												
IRRIGATED												
DORMANT SEEDING**												

IRRIGATION NEEDED DURING THIS PERIOD. TO CONTROL EROSION AT TIMES OTHER THAN IN THE SHADED AREAS. USE MULCH.

\* LATE SUMMER SEEDING DATES MAY BE EXTENDED 5 DAYS IF MULCH IS APPLIED.

\*\* INCREASE SEEDING APPLICATION BY 50%.

**TEMPORARY SEEDINGS**

TYPE OF SEED	1000 SQ. FT.	ACRE	REMARKS
WHEAT OR RYE	3.5 LBS.	2 BU.	COVER SEED 1" TO 1 1/2" DEEP
SPRING OATS	2.3 LBS.	3 BU.	COVER SEED 1" DEEP
ANNUAL RYEGRASS	1 LB.	40 LB.	COVER SEED 1/4" DEEP

\* NOT NECESSARY WHERE MULCH IS APPLIED.

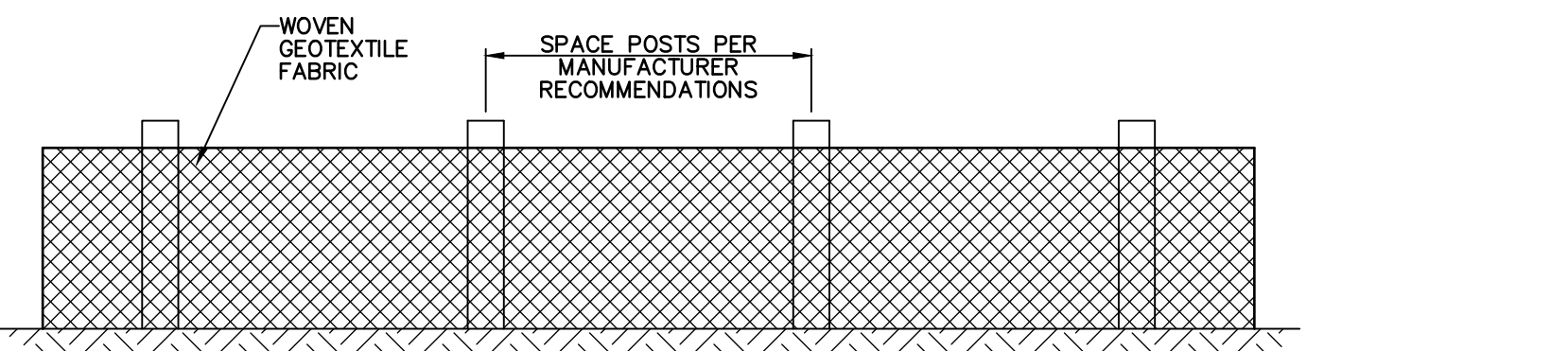
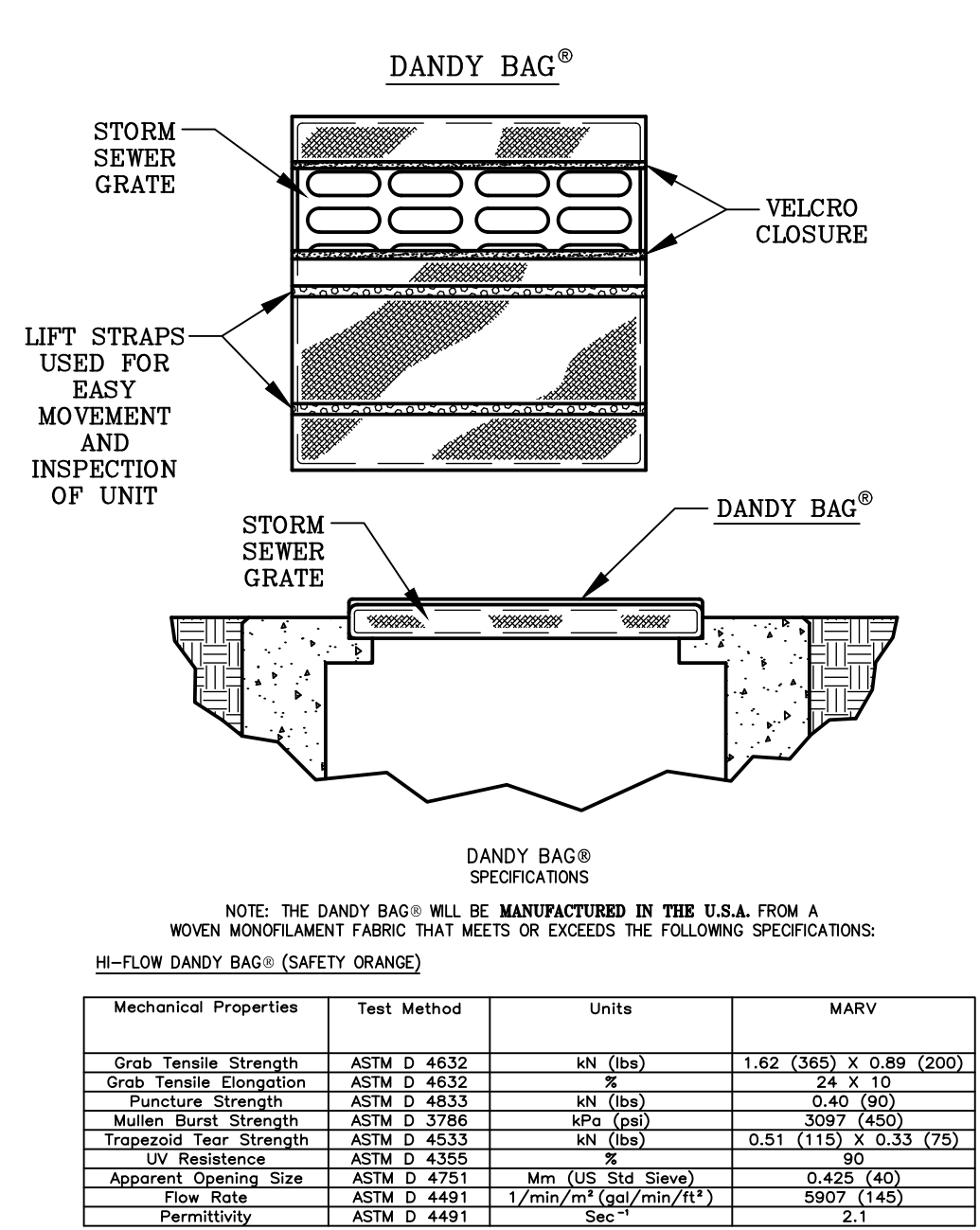
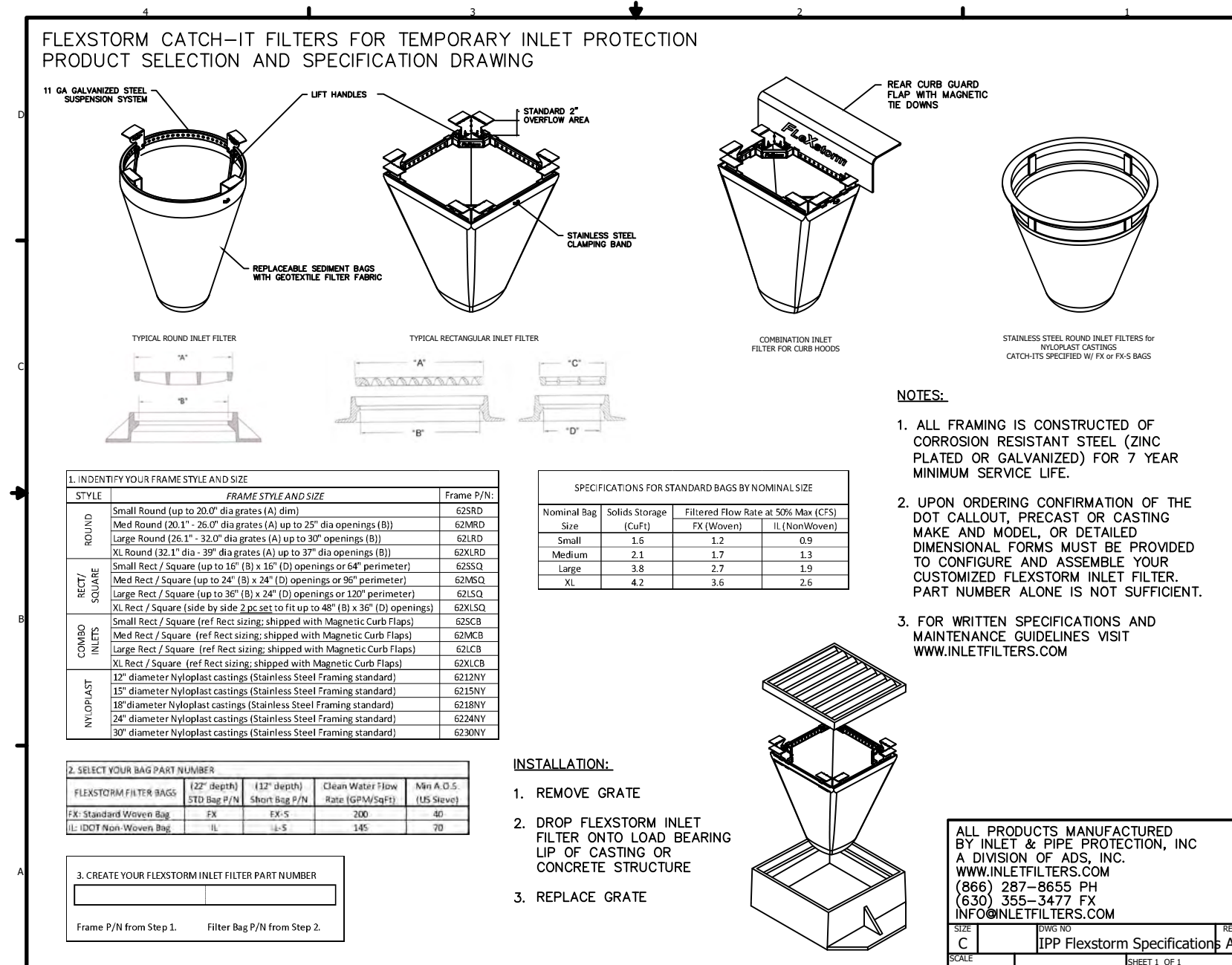

**NORTH AMERICAN GREEN**

TYPE	LONGEVITY	MAX. SLOPE	APPLICATION
S75	10 MONTHS	3:1	LOW FLOW SWALES
D575	60 DAYS	3:1	LOW FLOW SWALES
S150	10 MONTHS	2:1	MODERATE DISCHARGE SWALES
D150	60 DAYS	2:1	MODERATE DISCHARGE SWALES
SC150	2 YEARS	1:1	MEDIUM DISCHARGE SWALES
C125	3 YEARS	>1:1	HIGH DISCHARGE SWALES

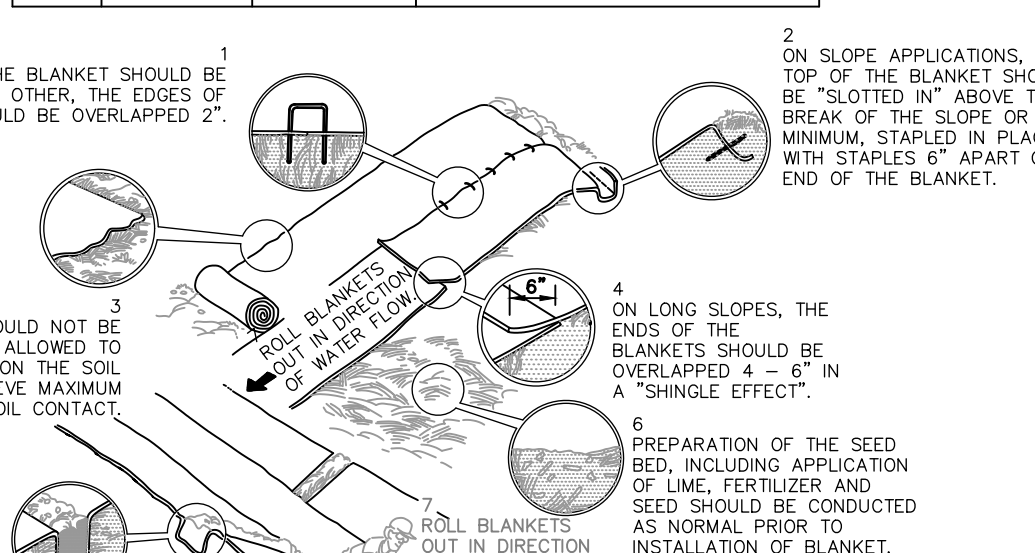
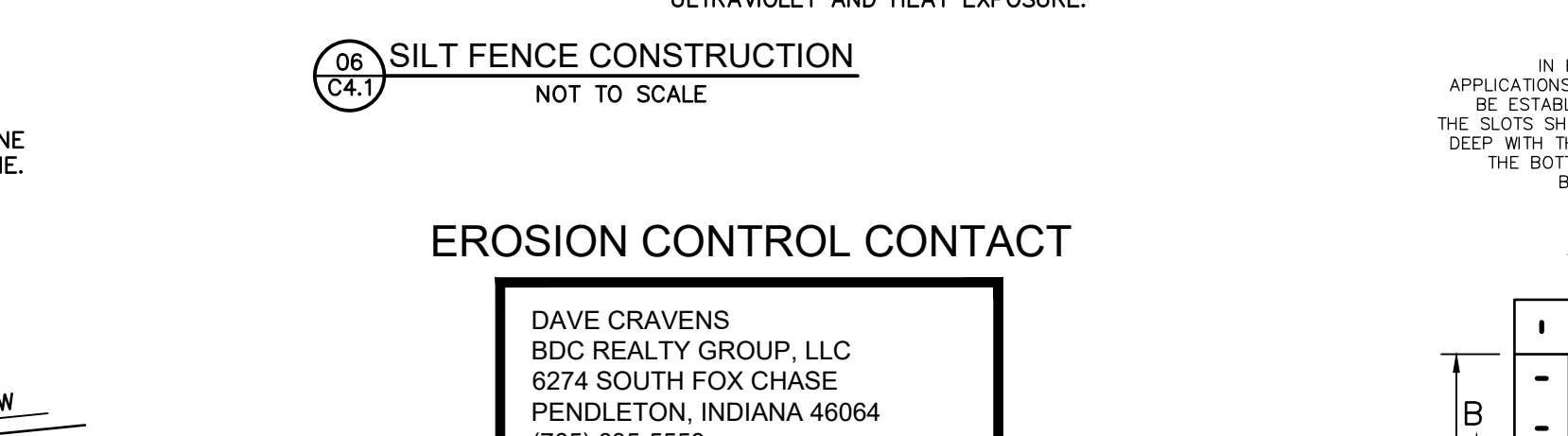
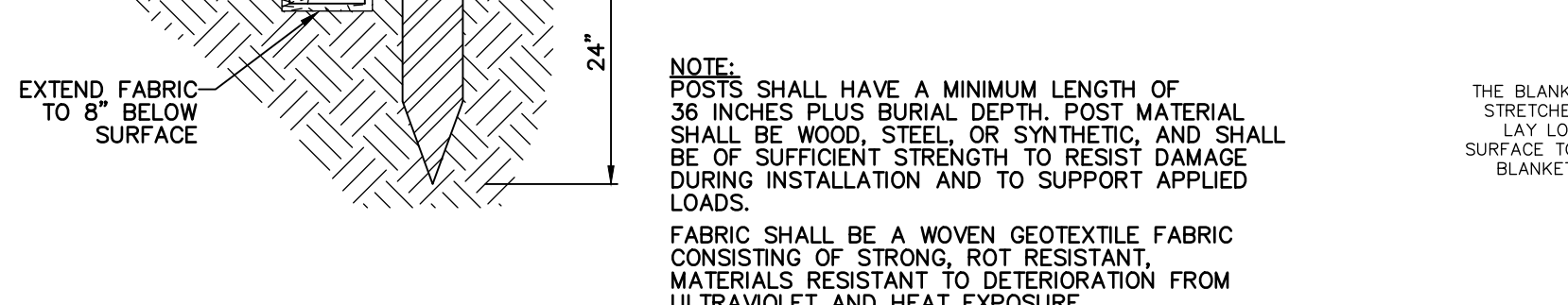
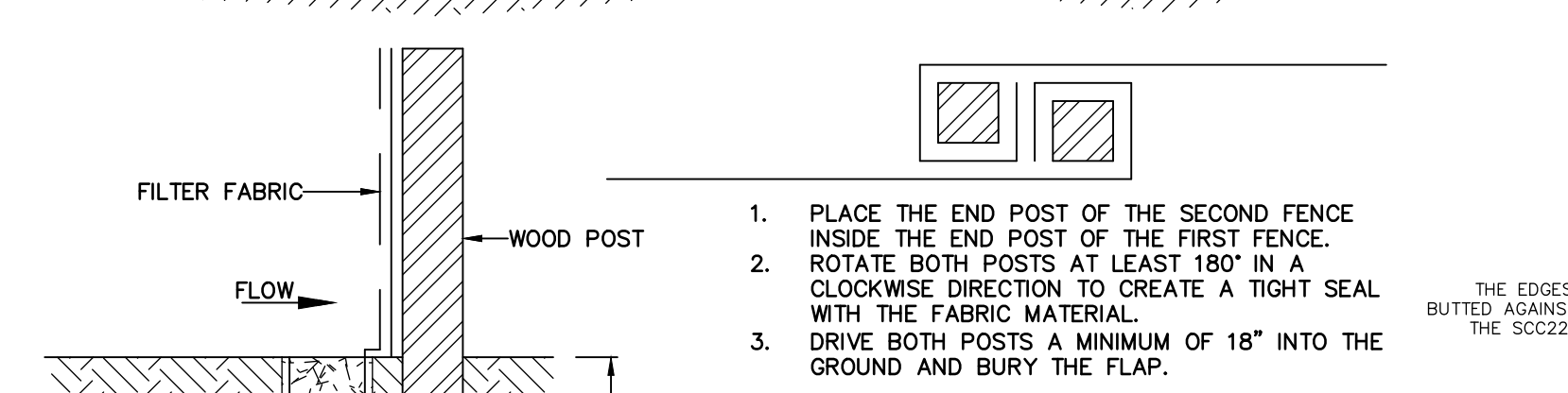

**EROSION CONTROL SCHEDULE**

EROSION CONTROL MEASURE	MAINTENANCE	INSTALLATION SEQUENCE
STONE ENTRANCE	AS NEEDED	PRIOR TO CLEARING AND GRADING
SILT FENCE	WEEKLY, AFTER STORM EVENTS AND AS NEEDED	PRIOR TO CLEARING AND GRADING
EXISTING INLET PROTECTION	WEEKLY, AFTER STORM EVENTS AND AS NEEDED	PRIOR TO CLEARING AND GRADING
TREE PROTECTION	WEEKLY, AFTER STORM EVENTS AND AS NEEDED	PRIOR TO CLEARING AND GRADING
TEMPORARY DIVERSIONS	WEEKLY, AFTER STORM EVENTS AND AS NEEDED	ALONG WITH ROUGH GRADING
TEMPORARY SEEDING	WATER AS NEEDED	AFTER ROUGH GRADING
PERMANENT SEEDING	WATER AS NEEDED	AFTER FINISH GRADING - AS SOON AS PRACTICAL UPON COMPLETION
EROSION CONTROL MATING	WEEKLY, AFTER STORM EVENTS AND AS NEEDED	AFTER FINISH GRADING - AS SOON AS PRACTICAL UPON COMPLETION
ROCK CHECK DAM	WEEKLY, AFTER STORM EVENTS AND AS NEEDED	AFTER FINISH GRADING - AS SOON AS PRACTICAL UPON COMPLETION
INLET PROTECTION	WEEKLY, AFTER STORM EVENTS AND AS NEEDED	AFTER EACH INLET IS PLACED
REMOVAL OF TREE PROTECTION	N/A	AFTER PERMANENT SEEDING
REMOVAL OF STRAW BALES	N/A	AFTER ALL AREAS DRAINING TO THESE AREAS ARE STABILIZED
REMOVAL OF INLET PROTECTION	N/A	AFTER ALL AREAS DRAINING TO THESE AREAS ARE STABILIZED
REMOVAL OF SILT FENCE	N/A	AFTER ALL AREAS DRAINING TO THESE AREAS ARE STABILIZED

**EROSION CONTROL MEASURES MAINTENANCE REQUIREMENTS**

**EROSION CONTROL BLANKET (SURFACE APPLIED) MAINTENANCE REQUIREMENTS:**

- DURING VEGETATIVE ESTABLISHMENT, INSPECT AFTER STORM EVENTS FOR ANY EROSION BELOW THE BLANKET.
- IF ANY AREA SHOWS EROSION, PULL BACK THAT PORTION OF THE BLANKET COVERING IT, ADD SOIL, RE-SEED THE AREA, AND RE-LAY AND STAPLE THE BLANKET.
- AFTER VEGETATIVE ESTABLISHMENT, CHECK THE TREATED AREA PERIODICALLY.

**TEMPORARY GRAVEL CONSTRUCTION ENTRANCE MAINTENANCE REQUIREMENTS:**

- INSPECT ENTRANCE PAD AND SEDIMENT DISPOSAL AREA WEEKLY AND AFTER STORM EVENTS OR HEAVY USE.
- RESHAPE PAD AS NEEDED FOR DRAINAGE AND RUNOFF CONTROL.
- TOP DRESS WITH CLEAN STONE AS NEEDED.
- IMMEDIATELY REMOVE MUD AND SEDIMENT TRACKED OR WASHED ONTO PUBLIC ROADS BY BRUSHING OR SWEEPING. FLUSHING SHOULD ONLY BE USED IF THE WATER IS CONVEYED INTO A SEDIMENT TRAP OR BASIN.
- REPAIR ANY BROKEN ROAD PAVEMENT IMMEDIATELY.

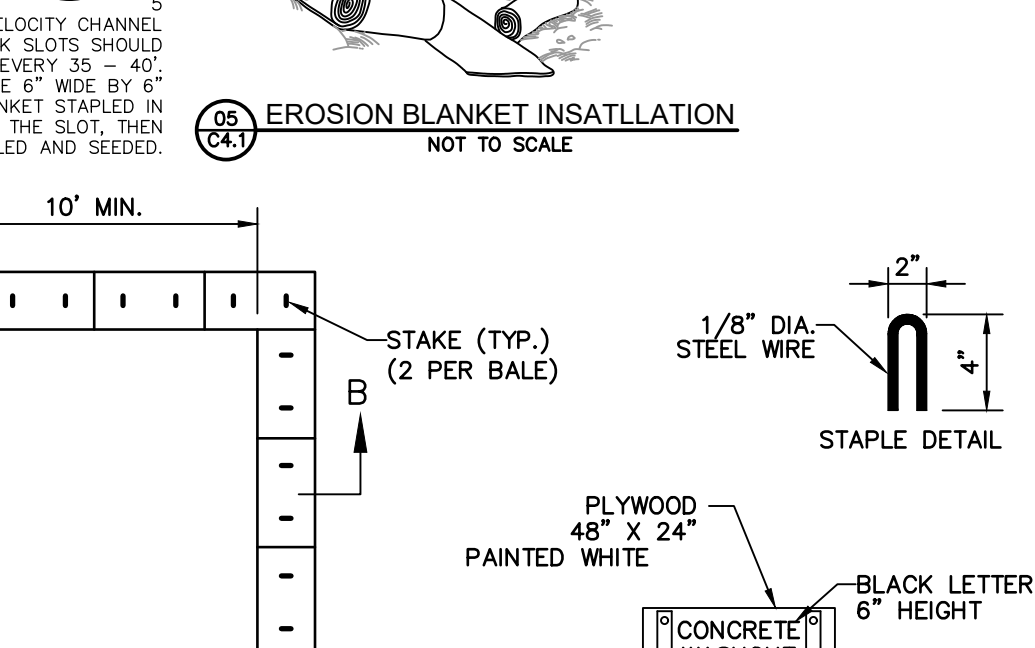
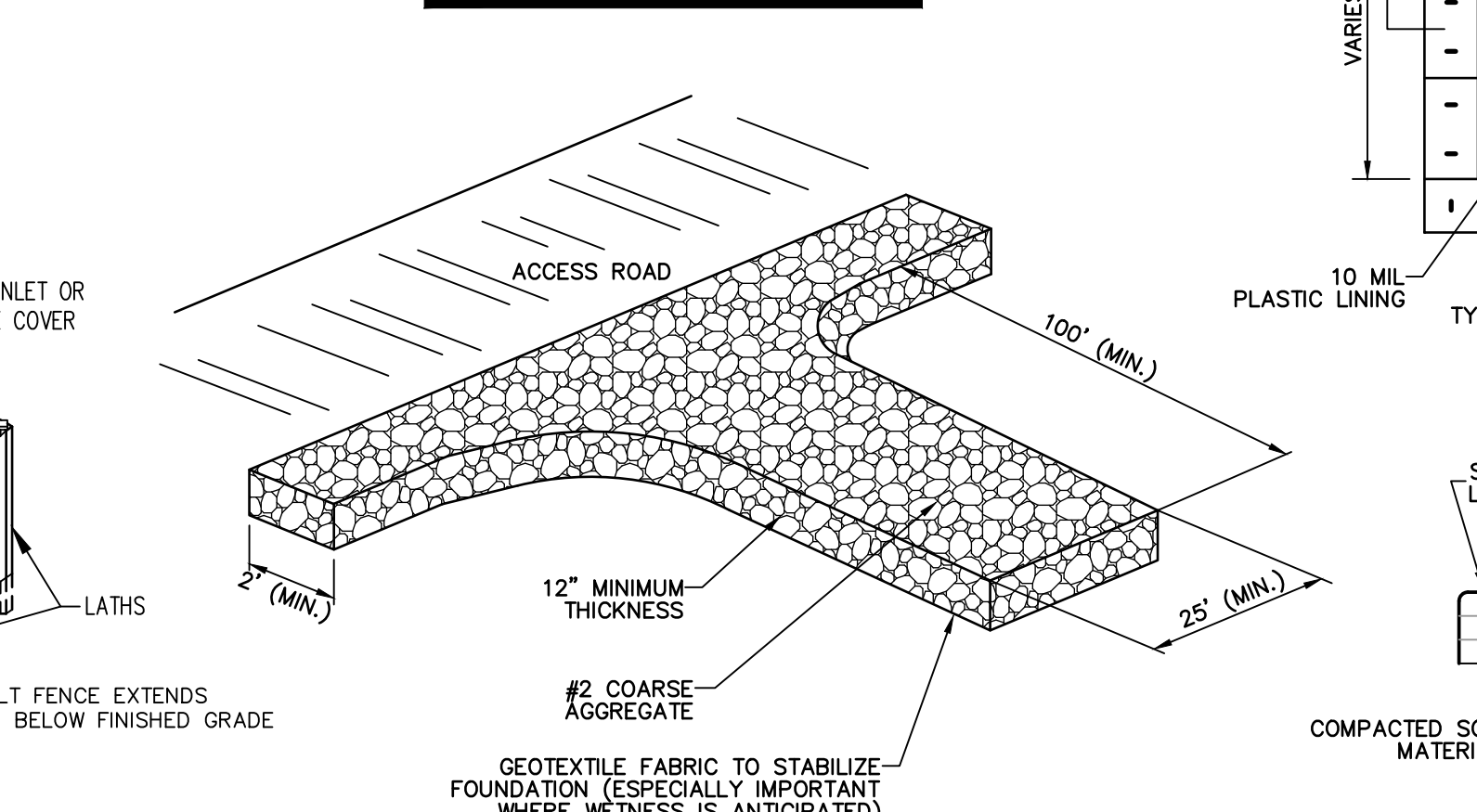
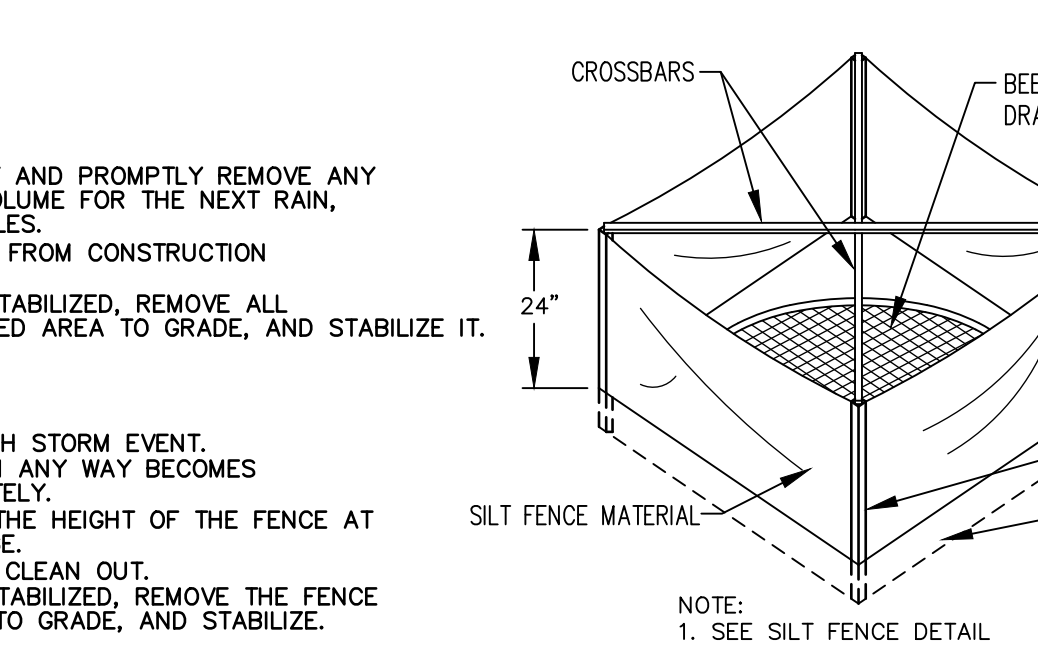
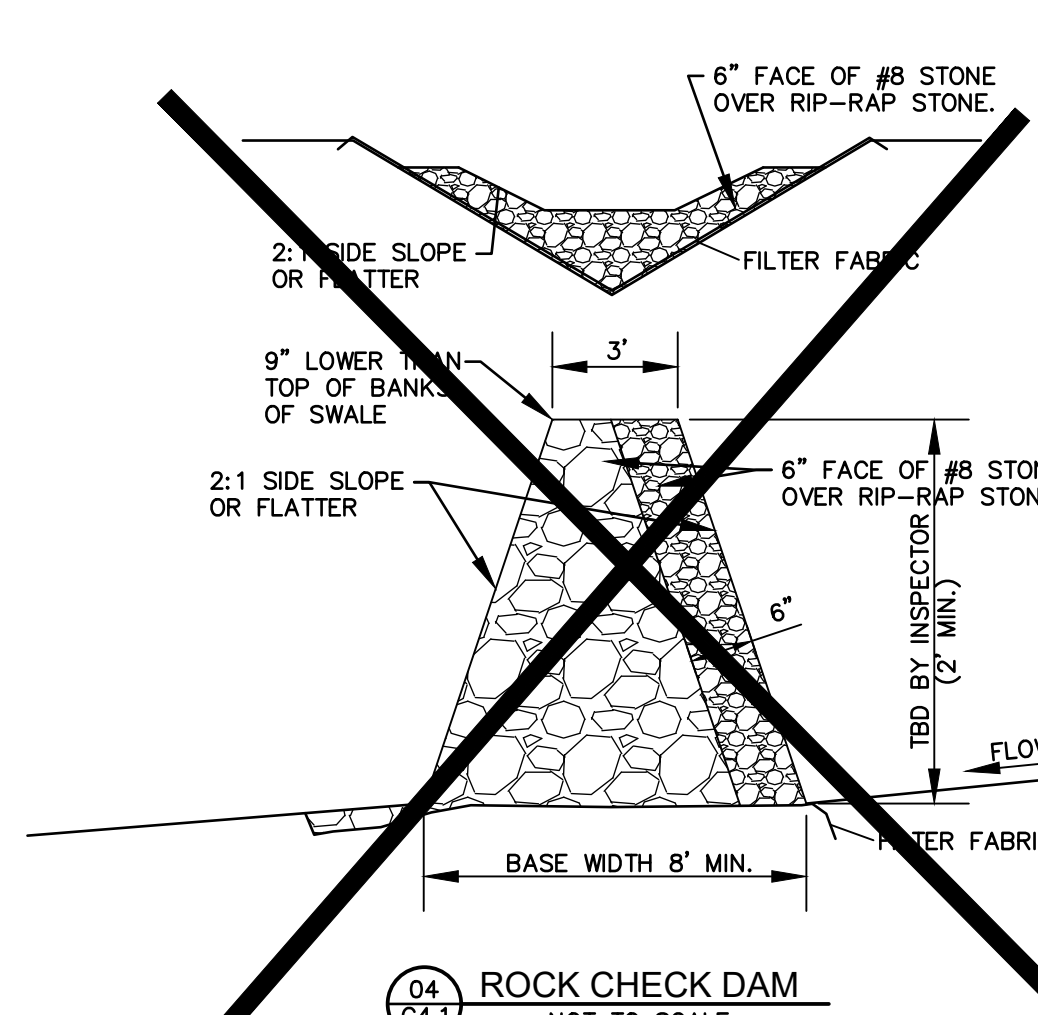

BDC REALTY GROUP, LLC  
6274 S FOX CHASE  
PENDLETON, IN 46064

**CIVIL SITE GROUP, INC.**  
718 Adams Street, Suite E  
Carmel, Indiana 46032  
Ph: (317) 810-1677

BRIAN S. CROSS  
REGISTERED PROFESSIONAL ENGINEER  
NO. PE10910647  
STATE OF INDIANA

*Brian S. Cross*  
DATE: 10/02/2025

DWN BY: BSC  
CHKD. BY: BSC  
SCALE: N/A  
DATE: 10/02/25

SHOPPES at BROOKSIDE - BLOCK A  
CR 600 W  
McCordsville, IN 46055

STORMWATER POLLUTION PREVENTION DETAILS  
PHASE III - NORTH BUILDING

PROJECT NUMBER  
BRG.008

DRAWING NUMBER  
**C4.1**  
SHEET 6 OF 24



**TOPOGRAPHIC & BOUNDARY NOTE**

ALL EXISTING HORIZONTAL AND VERTICAL INFORMATION HAS BEEN SHOWN PER A TOPOGRAPHIC SURVEY DATED 03/11/2024 PREPARED BY CROSSROAD ENGINEERS, P.C.; THEREFORE, CIVIL SITE GROUP, INC. CANNOT BE HELD RESPONSIBLE IF ACTUAL HORIZONTAL AND VERTICAL DATA IS DIFFERENT FROM THAT SHOWN ON THESE PLANS. CONTRACTOR IS RESPONSIBLE FOR FIELD VERIFICATION OF ALL EXISTING CONDITIONS PRIOR TO COMMENCING WITH CONSTRUCTION.

**FLOOD NOTE**

THIS LOT LIES ENTIRELY IN FLOOD HAZARD ZONE "X" AS SCALED FROM THE FLOOD INSURANCE RATE MAP (FIRM) FOR HANCOCK COUNTY, INDIANA, COMMUNITY NUMBER 180468, MAP NUMBER 18059C0016D, PANEL NUMBER 0016 D, DATED DECEMBER 4, 2007.  
REFERENCE NFIP FIRM MAP #18059C0016D, EFFECTIVE DATE: DECEMBER 4, 2007

**UTILITY LOCATE NOTE**

INDIANA 811 FAILED TO LOCATE ALL EXISTING UTILITIES ON AND/OR SURROUNDING THE SUBJECT SITE; THEREFORE, CONTRACTOR IS RESPONSIBLE TO LOCATE AND FIELD VERIFY ANY EXISTING UTILITIES BEFORE COMMENCING WITH CONSTRUCTION. CIVIL SITE GROUP, INC. CANNOT BE HELD RESPONSIBLE IF THE PROPOSED IMPROVEMENTS INTERFERE WITH ANY EXISTING UTILITY INFORMATION NOT SHOWN ON THESE PLANS.



**UTILITY VALVE NOTE**

ALL UTILITY VALVES AFFECTED BY CONSTRUCTION SHALL BE ADJUSTED TO FINAL GRADE AS NEEDED TO BE FLUSH WITH FINISHED PAVEMENT, SIDEWALK OR LANDSCAPE AREA.

**IRRIGATION NOTE**

SITE IRRIGATION IS NOT SHOWN ON THESE PLANS. IF SITE IRRIGATION IS REQUIRED, CONTRACTOR SHALL WORK WITH THE LOCAL WATER UTILITY TO DETERMINE THE REQUIREMENTS & LOCATION FOR THE IRRIGATION METER & SITE IRRIGATION SYSTEM.

**NOTE**

REFER TO ARCHITECTURAL & FOUNDATION PLANS FOR ALL BUILDING DIMENSIONS.

**GENERAL NOTES**

- TEMPORARY TRAFFIC CONTROL DURING CONSTRUCTION TO CONFORM TO APPLICABLE LOCAL AND STATE STANDARDS.
- ALL CONSTRUCTION ACTIVITY ON THIS SITE TO BE PERFORMED IN COMPLIANCE WITH APPLICABLE O.S.H.A. STANDARDS FOR WORKER SAFETY.
- IT SHALL BE THE CONTRACTORS RESPONSIBILITY TO FIELD VERIFY ALL UTILITY LOCATIONS & DEPTHS BEFORE CONSTRUCTION BEGINS.
- IT SHALL BE THE CONTRACTORS RESPONSIBILITY TO FIELD VERIFY ALL EXISTING ELEVATIONS BEFORE CONSTRUCTION BEGINS.

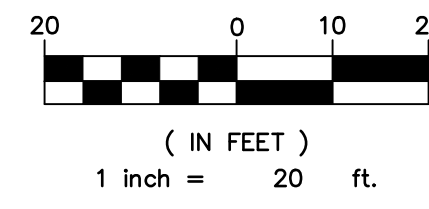

**REVISION RECORD**

REV	DATE	DESCRIPTION	DES BY	APP BY
1	11/04/25	TAC REVIEW REVISIONS	BSC	BSC

**LEGEND:**

- PROPERTY BOUNDARY
- RIGHT-OF-WAY
- PROPOSED STORM SEWER
- PROPOSED STORM STRUCTURE
- PROPOSED ELECTRIC SERVICE
- PROPOSED TELECOM SERVICE
- PROPOSED GAS SERVICE
- PROPOSED RPM - BLUE REFLECTOR
- PROPOSED PRIMARY 3Ø NINESTAR CONNECT ELECTRIC TRANSFORMER
- KICKER, PLUG, TEE, BEND FITTING
- GATE VALVE
- HYDRANT WITH HYDRANT VALVE
- 6" SAN. LATERAL CLEANOUT--CLEANOUTS INSTALLED IN PAVED AREAS MUST HAVE A HEAVY DUTY CASTING TO WITHSTAND TRAFFIC LOADING. REFER MCCORDSVILLE DETAIL SHEETS 8-10

**UTILITY CROSSINGS UNDER PAVEMENT**

ALL UTILITY CROSSINGS UNDER PAVEMENT MUST BE JACK & BORE OR DIRECTIONAL DRILLED. OPEN CUTS SHALL NOT BE PERMITTED.

**NOTE**

UTILITY WORK WITHIN THE EXISTING RIGHT-OF-WAY OR WITHIN 5' OF EXISTING R/W PAVEMENT REQUIRES FLOWABLE FILL.

**CITIZENS ENERGY NOTES:**

**Domestic Water / Fire Service:**

- All work must be completed by a bonded Contractor according to Section 1.13 of the Water Standards.
- The water/fire service permit cannot be approved until the sanitary lateral permit has been approved.
- Please note that open cutting the asphalt path and the method of restoration is subject to the City's approval, not Citizens.

**Service Line Requirements:**

- Ensure that a minimum of a 10' horizontal separation and an 18" vertical separation between sewer lines (sanitary or storm) and the water service lines is maintained.
- A sewer and water crossing must be at a minimum of 45 degrees.

**Domestic Service:**

- Please note that copper or ductile iron pipe must be run from 5 feet outside of the building footer into the building to the meter setup.
- Please note that open cutting the asphalt path and the method of restoration is subject to the City's approval, not Citizens.

**Fire Service:**

Please submit for a hydrant flow request: <https://www.citizensenergygroup.com/For-Partners/Contractors-Builders/Permits-and-Forms/Hydrant-Flow-Test>.

**Sanitary Sewer Lateral Service:**

- Full depth granular backfill required under pavement. Refer to Fig 400.01 on Sheet C7.3.
- Ensure that a minimum of a 10' horizontal separation and an 18" vertical separation between sewer lines (sanitary or storm) and the water service lines is maintained.
- Sewer lateral and utility crossings must be at a minimum of 45 degrees horizontal.
- Cleanouts installed in paved areas must have a heavy duty casting to withstand traffic loading. Refer to Fig 400.10 on Sheet C7.3.
- Tracer wire required to be attached to sewer laterals per Citizens Westfield Stds.

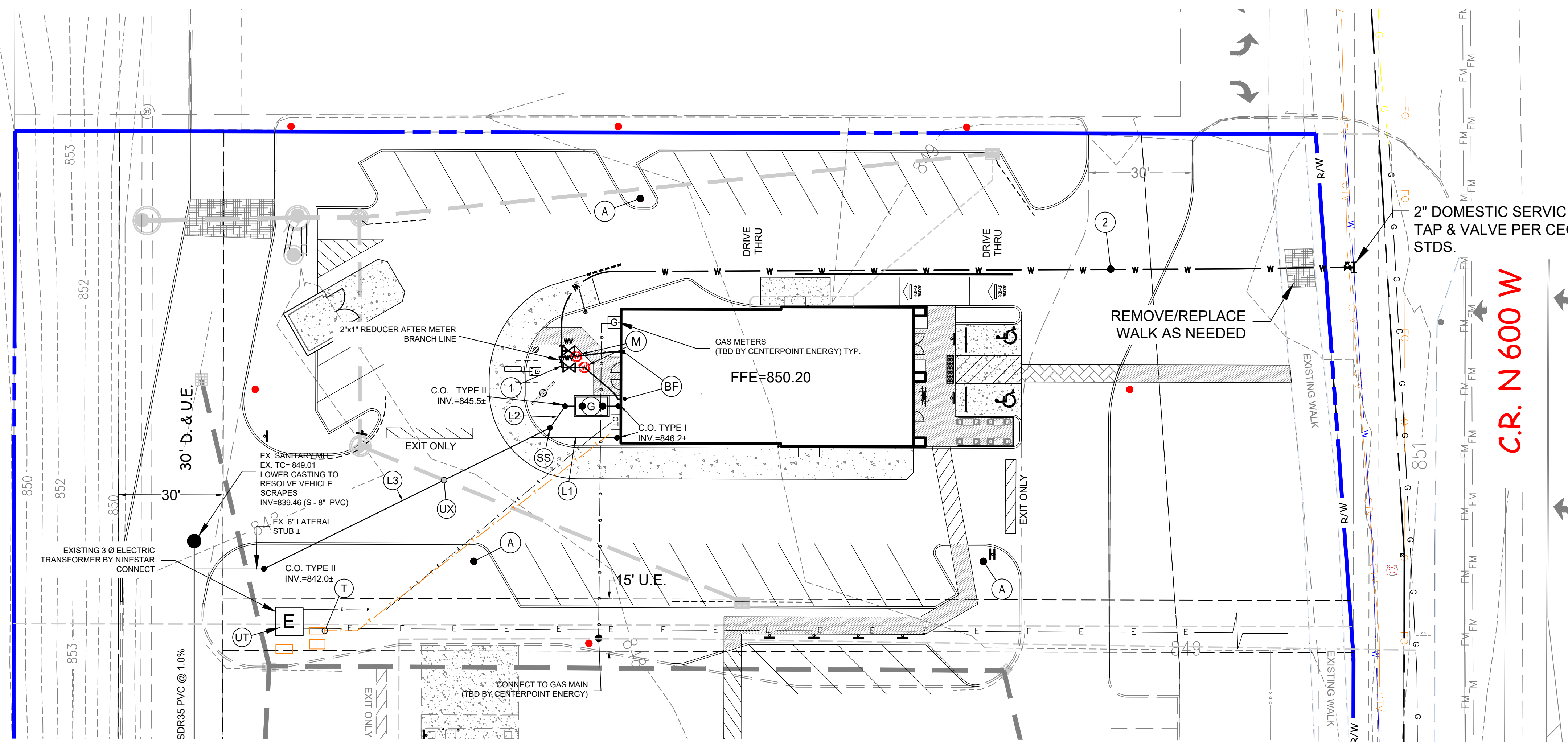

**PLAN NOTES:**

- (A) LIGHT POLE FOUNDATION (REFER TO LIGHTING PLAN)
- (UX) UTILITY CROSSING
- (L1) 15± LF OF 6-INCH SDR35 PVC (ASTM D-3034) @ 1.04% MIN. WITH TRACER WIRE ATTACHED PER MCCORDSVILLE STDS. REFER MCCORDSVILLE DETAIL SHEETS 8 & 9
- (L2) 26± LF OF 6-INCH SDR35 PVC (ASTM D-3034) @ 1.04% MIN. WITH TRACER WIRE ATTACHED PER MCCORDSVILLE STDS. REFER MCCORDSVILLE DETAIL SHEETS 8 & 9
- (L3) 92± LF OF 6-INCH SDR35 PVC (ASTM D-3034) @ 1.04% MIN. WITH TRACER WIRE ATTACHED PER MCCORDSVILLE STDS. REFER MCCORDSVILLE DETAIL SHEETS 8 & 9
- (CC) CONCRETE CRADLE REQ'D. BETWEEN PIPES
- (18) 10 FOOT HORIZONTAL & 18-INCH VERTICAL SEPARATION REQ'D. BETWEEN SEWER (SANITARY OR STORM) & WATER SERVICE LINES
- (UT) EXISTING 3Ø 120/208V ELECTRIC TRANSFORMER BY NINESTAR CONNECT
- (M) 3/4-INCH METER PIT PER CEG STDS. RPZ TO BE SET INSIDE BLDG. REFER TO CEG STD. PRACTICE T
- (1) 1-INCH I.D. COMMON DOMESTIC WATER SERVICE LINE (CTS POLY AWWA, PE3408 SDR9)
- (2) 2-INCH I.D. COMMON DOMESTIC WATER SERVICE LINE (CTS POLY AWWA, PE3408 SDR9); REFER TO CEG STD. PRACTICE N
- (BF) RPZ BACKFLOW TO BE SET INSIDE BLDG. PER CEG STDS.
- (T) TELECOM SERVICE - 4-INCH PVC CONDUIT (QTY 2)
- (G) 1000 GALLON (MIN) GREASE TRAP. REFER TO MCCORDSVILLE DETAIL SHEET 8 & DETAIL SHEET C7.1
- (SS) SAMPLING STRUCTURE DOWNSTREAM OF GREASE TRAP PER MCCORDSVILLE STDS.

**UTILITY NOTES**

- IT SHALL BE THE RESPONSIBILITY OF EACH CONTRACTOR TO VERIFY ALL EXISTING UTILITIES AND CONDITIONS PERTAINING TO THEIR PHASE OF WORK. IT SHALL ALSO BE THE CONTRACTORS RESPONSIBILITY TO CONTACT THE OWNER OF THE VARIOUS UTILITIES FOR PROPER STAKE LOCATIONS FOR EACH UTILITY BEFORE WORK IS STARTED. THE CONTRACTOR SHALL NOTIFY IN WRITING THE OWNER OR THE ENGINEER OF ANY CHANGES, OMISSIONS, OR ERRORS FOUND ON THESE PLANS OR IN THE FIELD BEFORE WORK IS STARTED OR RESUMED.
- STANDARD SPECIFICATIONS FOR THE LOCAL GOVERNING AGENCY SHALL APPLY FOR ALL SANITARY SEWERS, STORM SEWERS, AND WATER MAINS.
- ANY PART OF THE SANITARY OR STORM SEWER TRENCHES RUNNING UNDER PAVED AREAS TO BE BACKFILLED WITH GRANULAR MATERIAL.
- ALL WATER MAINS TO HAVE 60" MINIMUM COVER OVER TOP OF PIPE.
- STERILIZATION OF WATER MAIN SHALL BE IN ACCORDANCE WITH STATE BOARD OF HEALTH REQUIREMENTS. (APPLIES TO COMMERCIAL ONLY)
- CONTRACTOR RESPONSIBLE TO INSTALL ALL UNDERGROUND CONDUIT PER UTILITY COMPANY'S SPECIFICATIONS.
- CONTRACTOR RESPONSIBLE FOR RESTORATION TO ALL AREAS AFFECTED DURING CONSTRUCTION. REFER TO THE TOWN OF FISHERS STANDARDS FOR RESTORATION REGS.
- CONTRACTOR TO LOCATE ALL EXISTING UTILITIES AT ANY PROPOSED CROSSING AND PROVIDE EXISTING TOP-OF-PIPE ELEVATIONS WITHIN 10 DAYS OF NOTICE TO PROCEED. PROVIDE CONCRETE CRADLE AS REQUIRED FOR ANY VERTICAL SEPARATION LESS THAN 18 INCHES.

**SEWER LATERAL BACKFILL**

FULL DEPTH GRANULAR BACKFILL IS REQ'D. UNDER ALL PAVEMENT. REFER TO MCCORDSVILLE DETAILS SHEETS 9 & 10

**SITE LIGHTING NOTE**

SITE LIGHTING IS NOT SHOWN ON THESE PLANS. 2-1/2" CONDUITS (SITE LIGHTING & SECURITY) REQUIRED TO ALL PARKING LOT LIGHT POLE LOCATIONS. ALL CONDUIT RUNS SHALL BE TRENCHED INSTALLED WITH COMPACTED GRANULAR BACKFILL TO PAVEMENT SUBGRADE - FLOWED OR BAKED INSTALLATION OF CONDUITS ARE PROHIBITED

**BDC REALTY GROUP, LLC**  
6274 S FOX CHASE  
PENDLETON, IN 46064

**CIVIL SITE GROUP, INC.**  
718 Adams Street, Suite E  
Carmel, Indiana 46032  
Ph: (317) 810-1677

DATE: 10/02/2025

DWN BY: BSC  
CHKD. BY: BSC  
SCALE: 1" = 20'  
DATE: 10/02/25

**THE SHOPS at BROOKSIDE - BLOCK A**  
CR 600 W  
McCordsville, IN 46055

**UTILITY PLAN**  
PHASE III - NORTH BUILDING

PROJECT NUMBER  
**BRG.008**

DRAWING NUMBER  
**C5.0**  
SHEET 8 OF 24

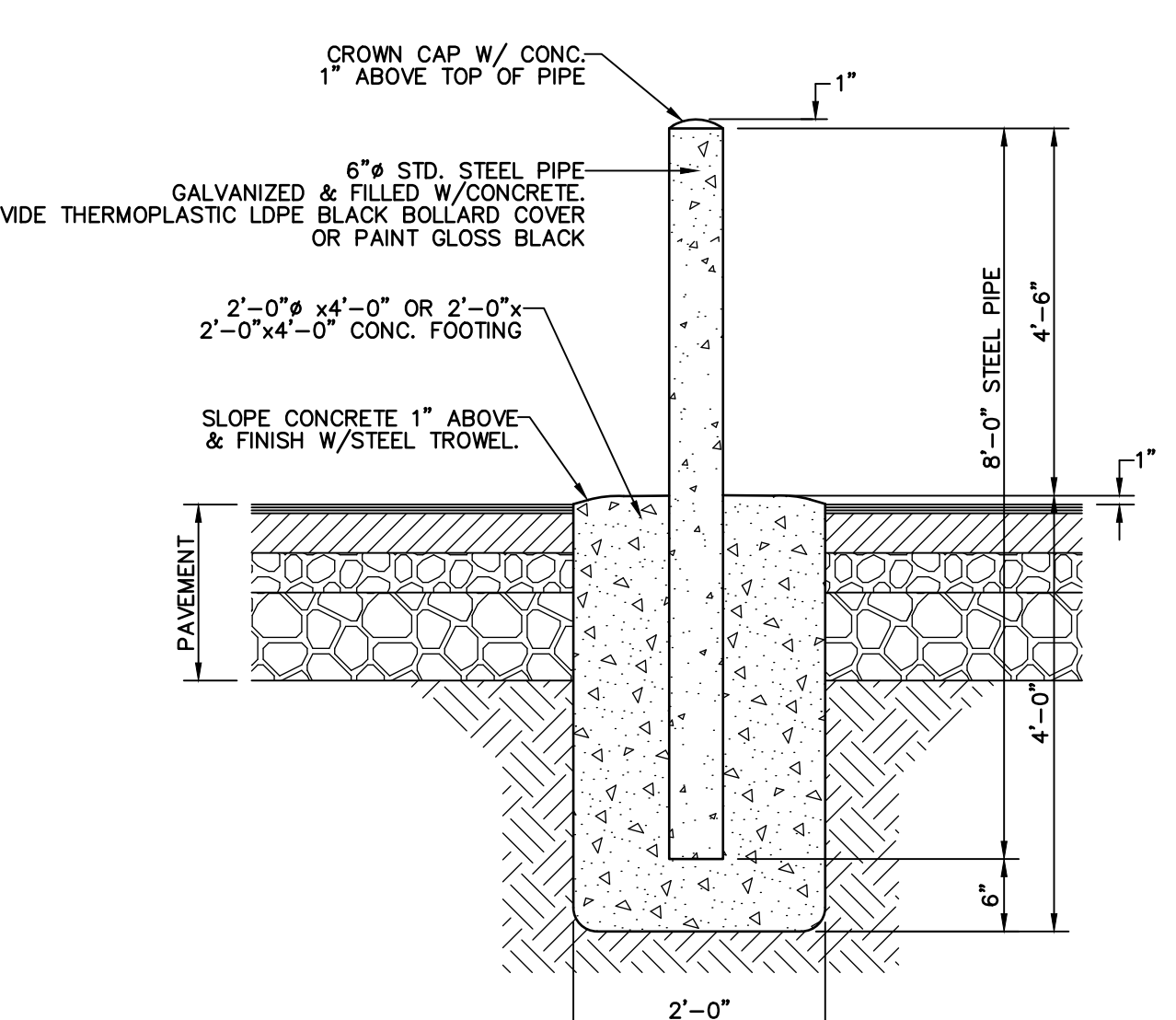
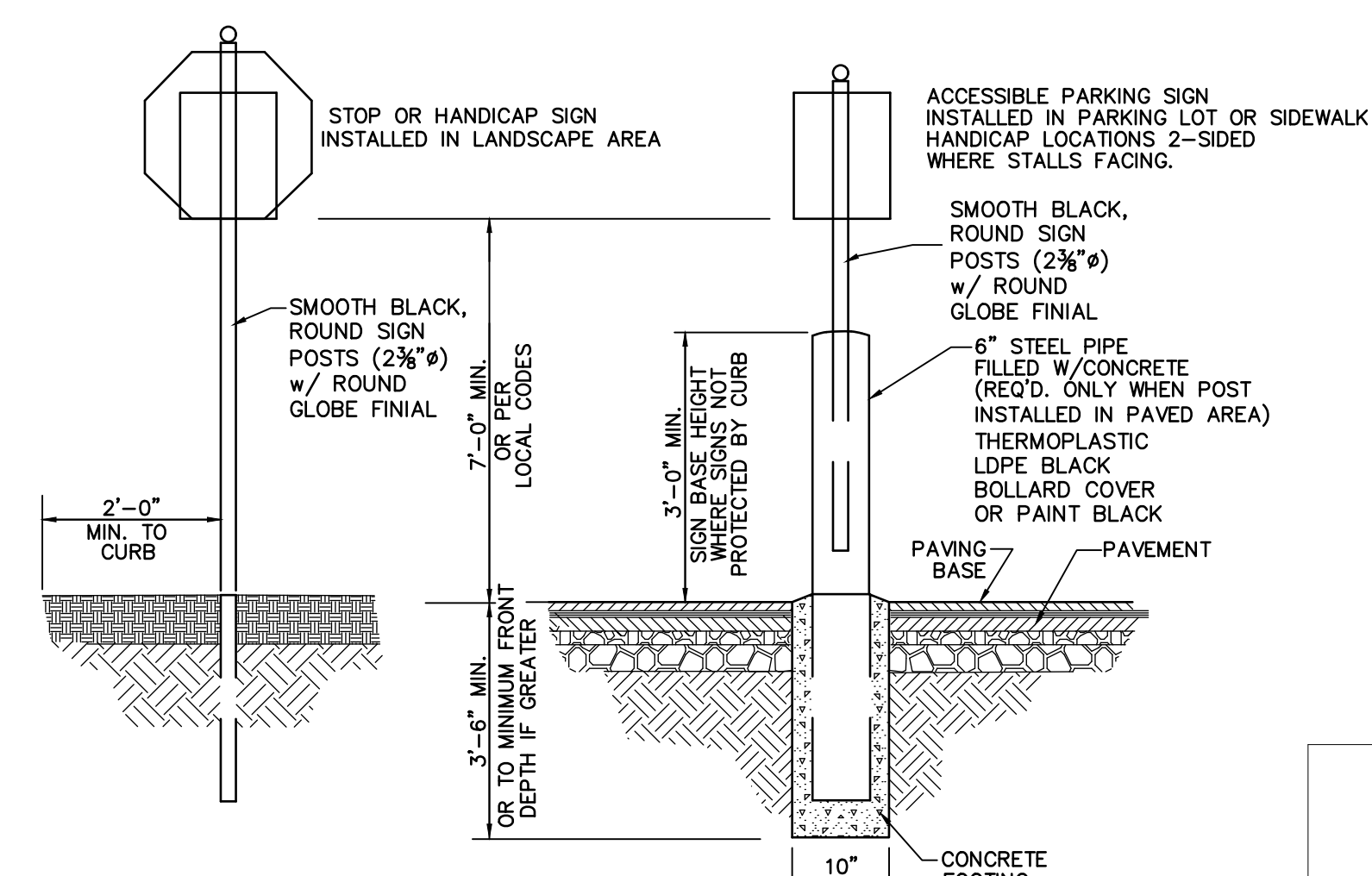
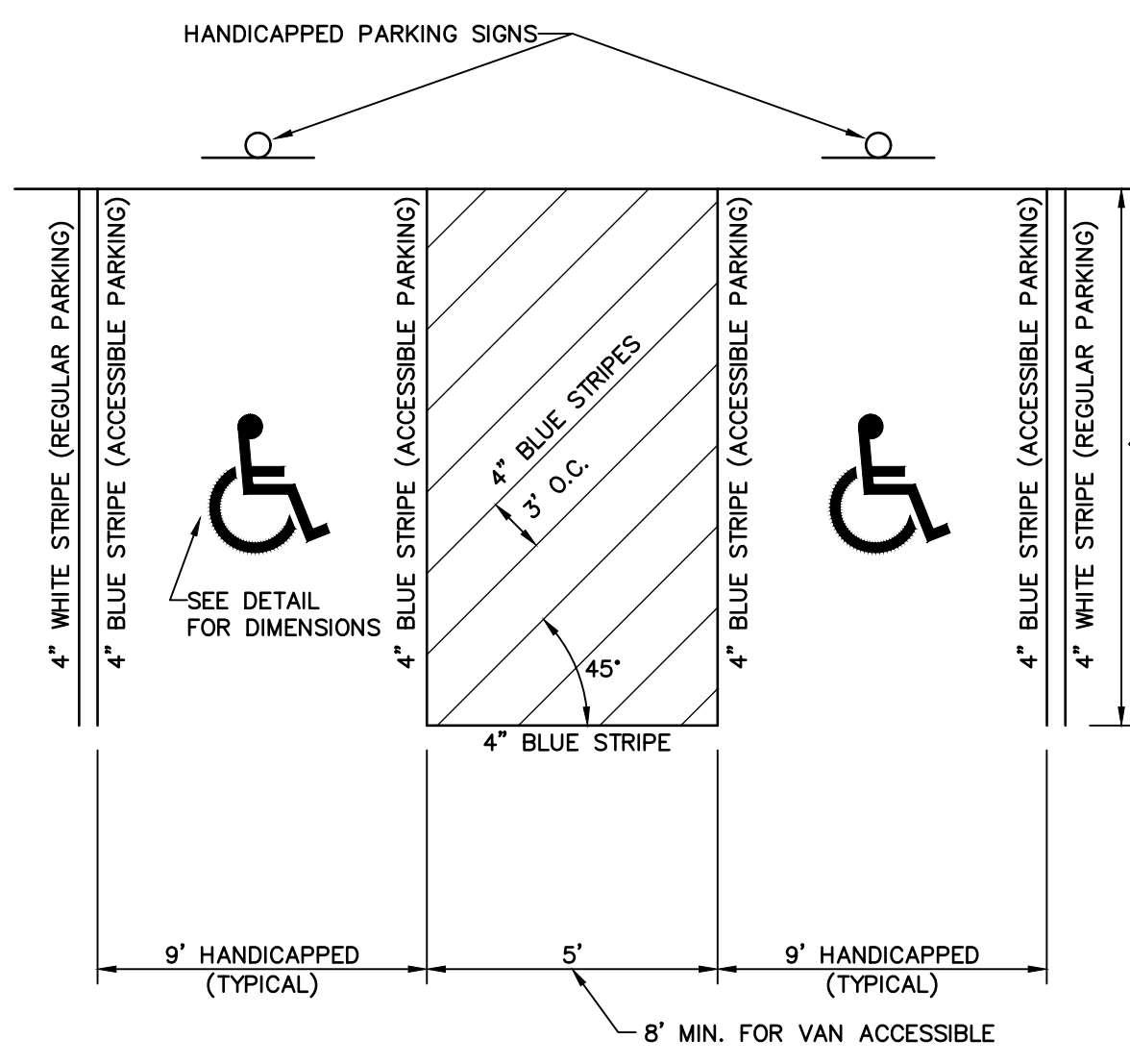
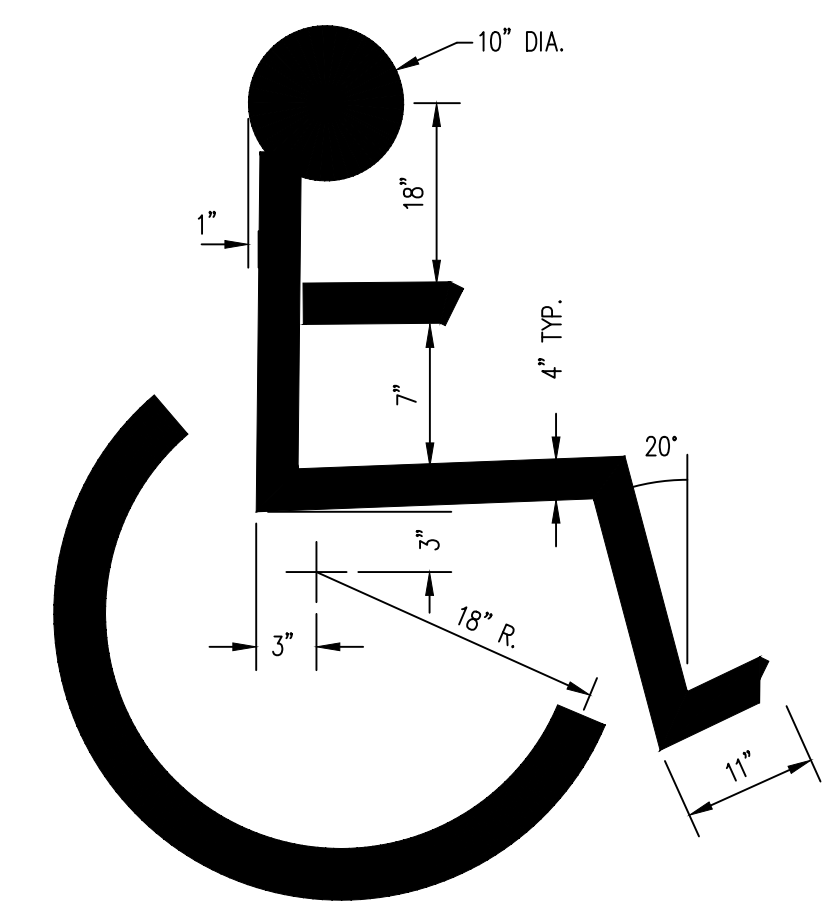
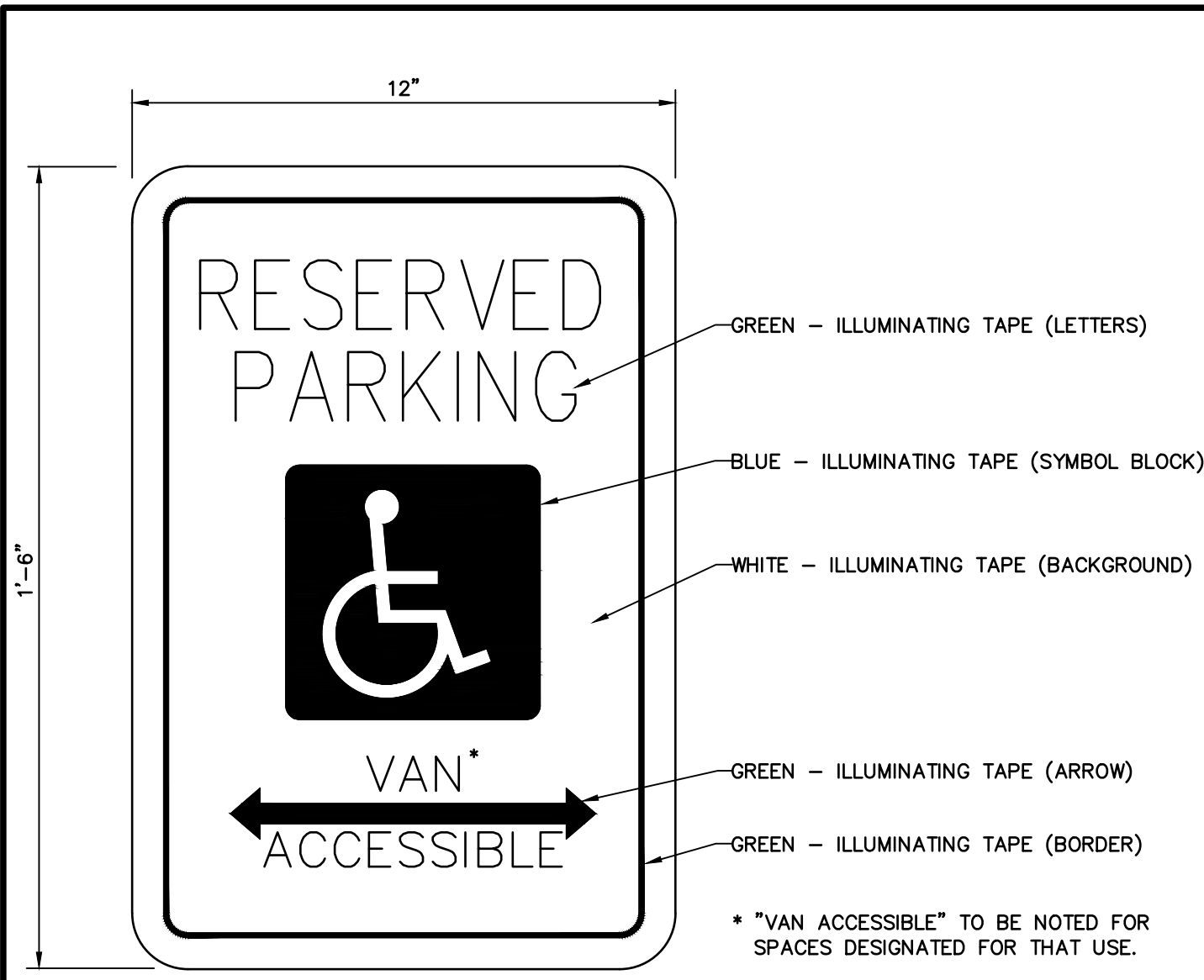

**Armor-Tile Tactile Systems**

ENGINEERED PLASTICS, INC.  
300 INTERNATIONAL DR., SUITE 100  
WILLIAMSVILLE, NY  
USA, 14221  
1 (800) 682-2525  
PHONE: (716) 629-3626  
FAX: 1 (800) 769-4463  
www.armor-tile.com

SELECT DESIRED COLOR:  
 LIGHT GREY  
 DARK GREY  
 DARK BLACK  
 PEARL WHITE  
 FEDERAL YELLOW  
 BLACK RED  
 CUSTOM CONTACT BLACK (MANUFACTURER)

DETAIL 1: 24" x 24" PLAN TILE

SECTION A-A: 10" HOLE THROUGH EMBEDMENT FLANGES (3 PER FLANGE)

SECTION B-B: 10" HOLE THROUGH EMBEDMENT FLANGES (3 PER FLANGE)

INTERNAL EMBEDMENT FLANGE AT 3" O.C.

NOTES:  
 1. INSTALLATION TO BE COMPLETED IN ACCORDANCE WITH MANUFACTURER'S SPECIFICATIONS.  
 2. DO NOT SCALE DRAWINGS.  
 3. FOR CUSTOM SIZING CONTACT MANUFACTURER.  
 4. CONTRACTOR NOTE: FOR PRODUCT AND COMPANY INFORMATION VISIT www.CADdetails.com/info REFERENCE NUMBER 61-016

**11 CAST IN PLACE**  
36" x 36" (ADA-C-246)

61-0216  
PROTECTED BY COPYRIGHT - 11/06/08  
www.CADdetails.com

**TOWN OF MCCORDSVILLE STANDARDS**

CONTRACTOR TO CONSTRUCT ALL APPLICABLE SITE IMPROVEMENTS TO THE TOWN OF MCCORDSVILLE CURRENT STANDARDS PER THE ATTACHED STANDARD DETAIL SHEETS.

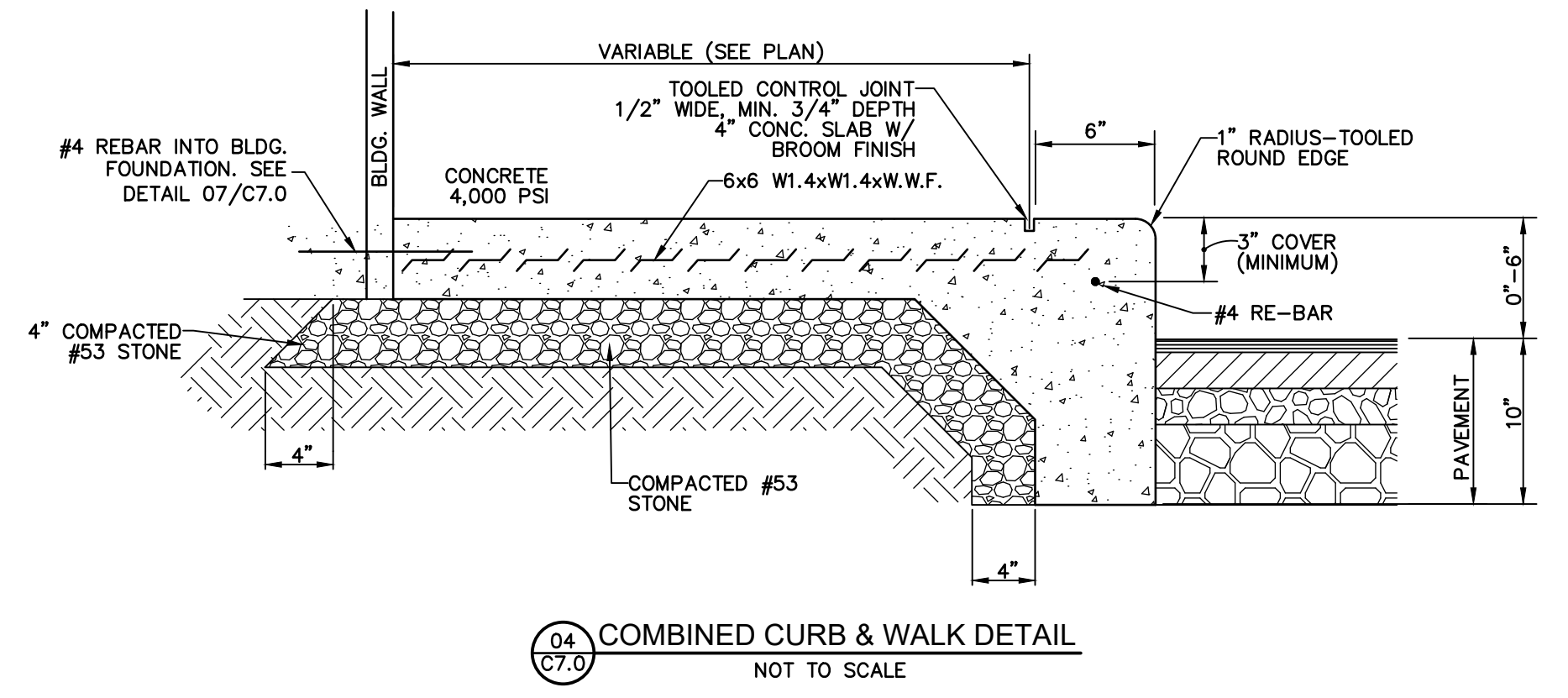
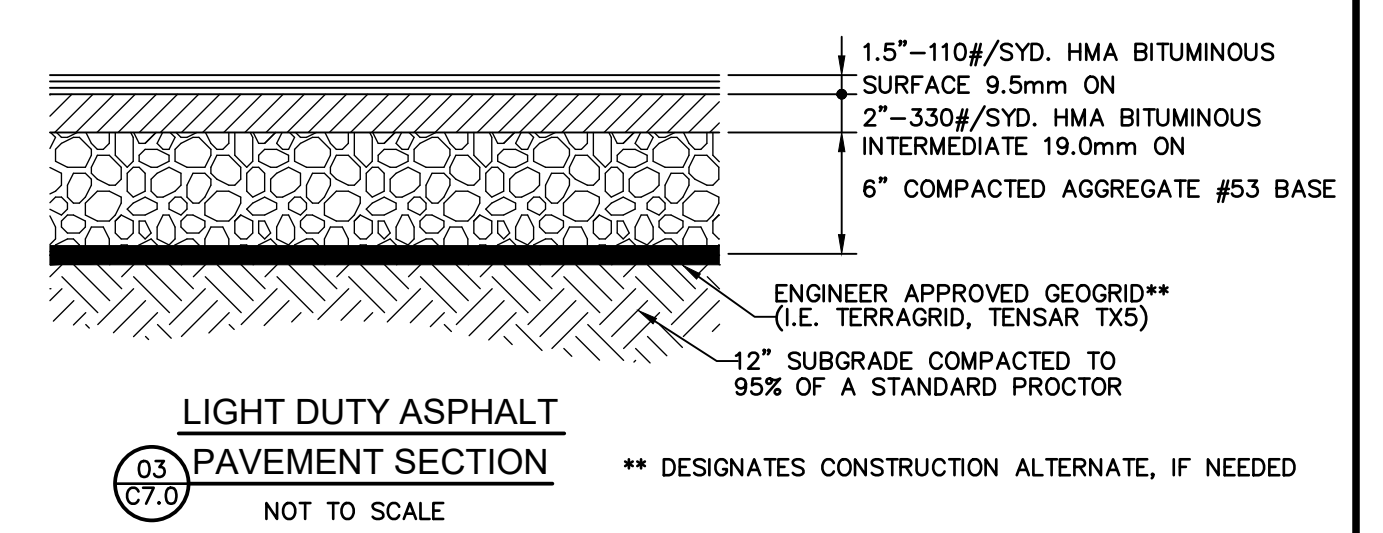
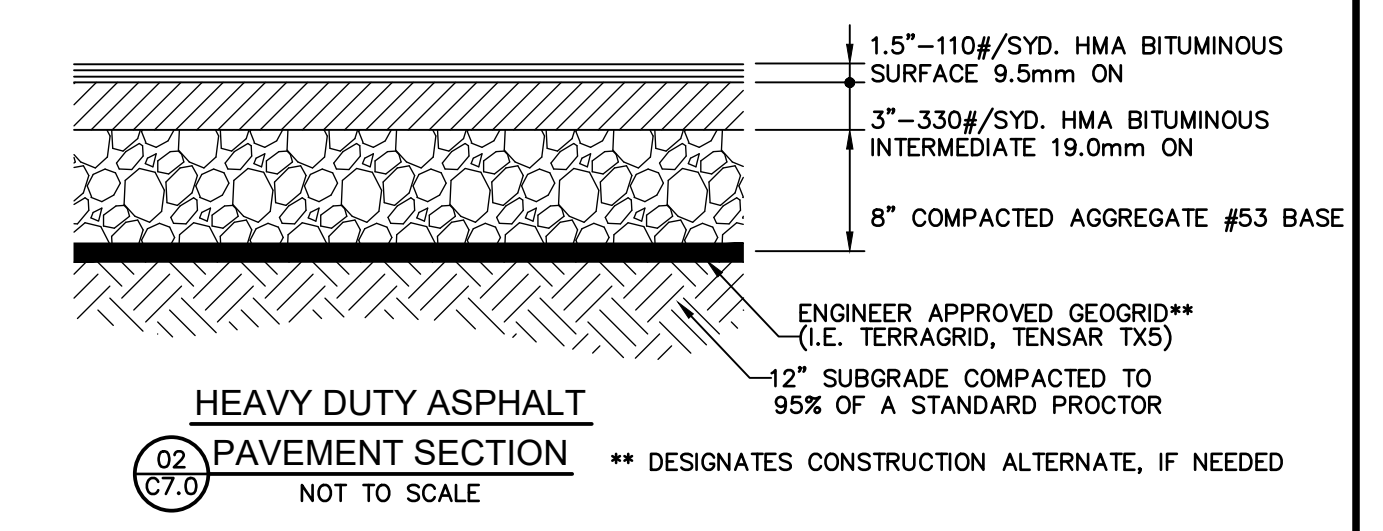
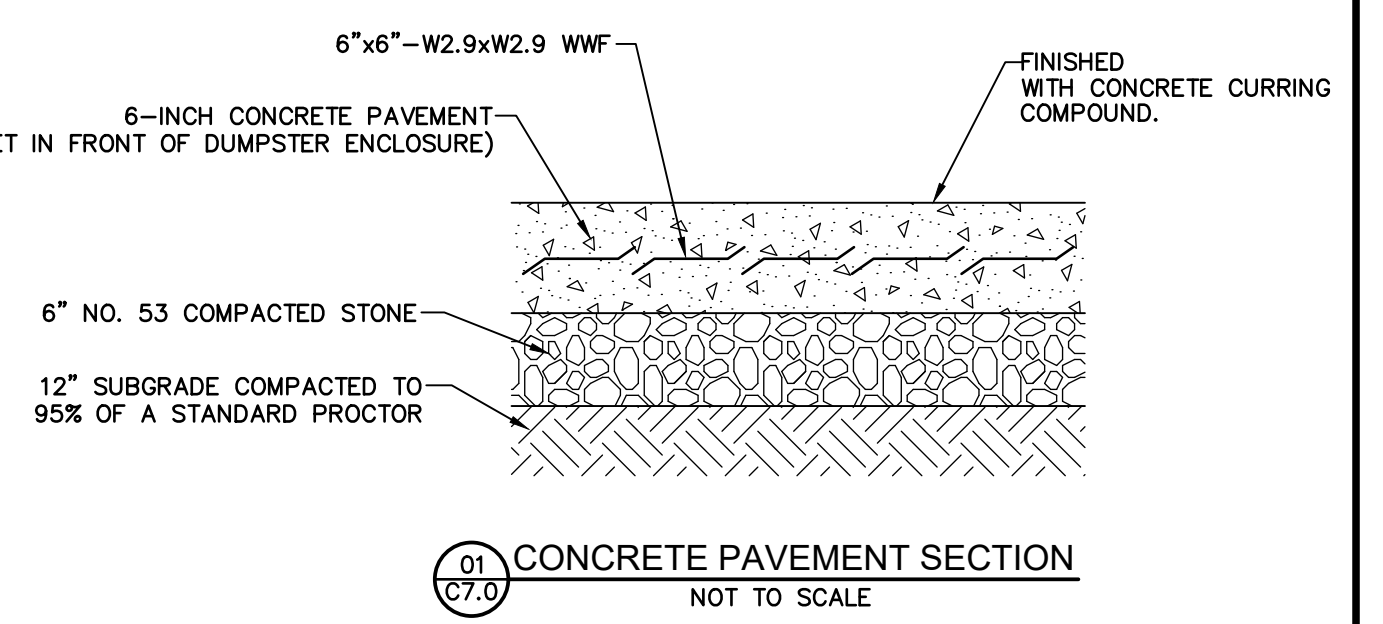
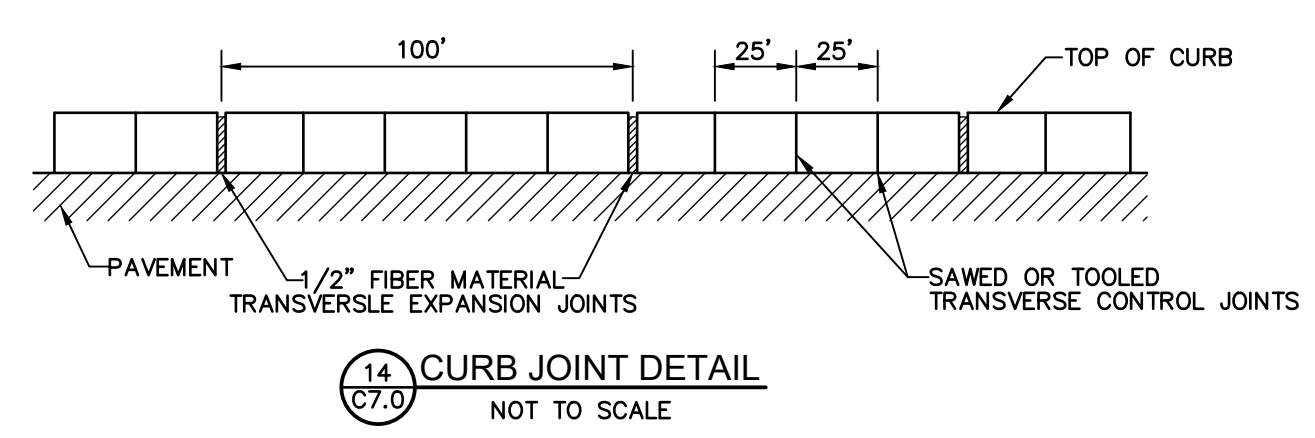
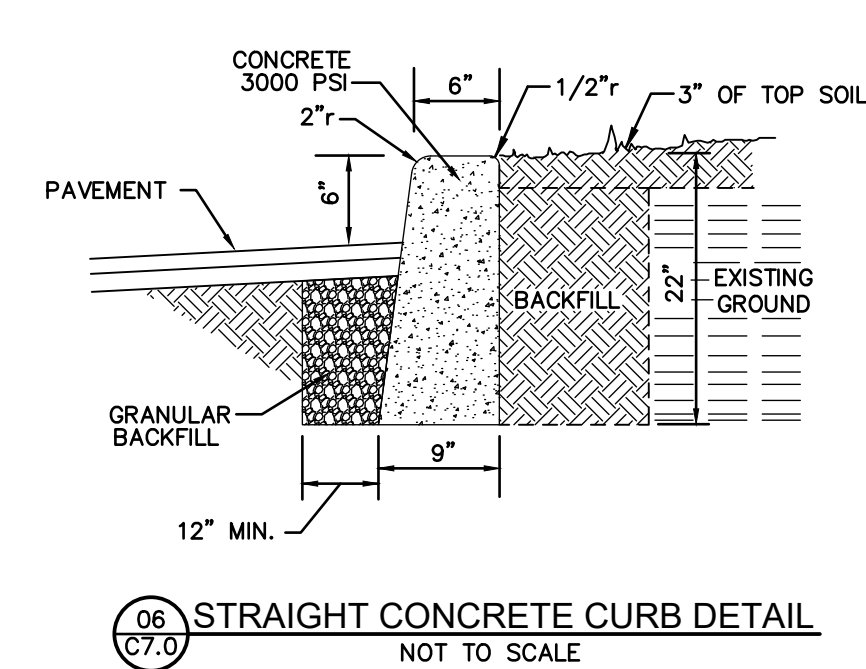
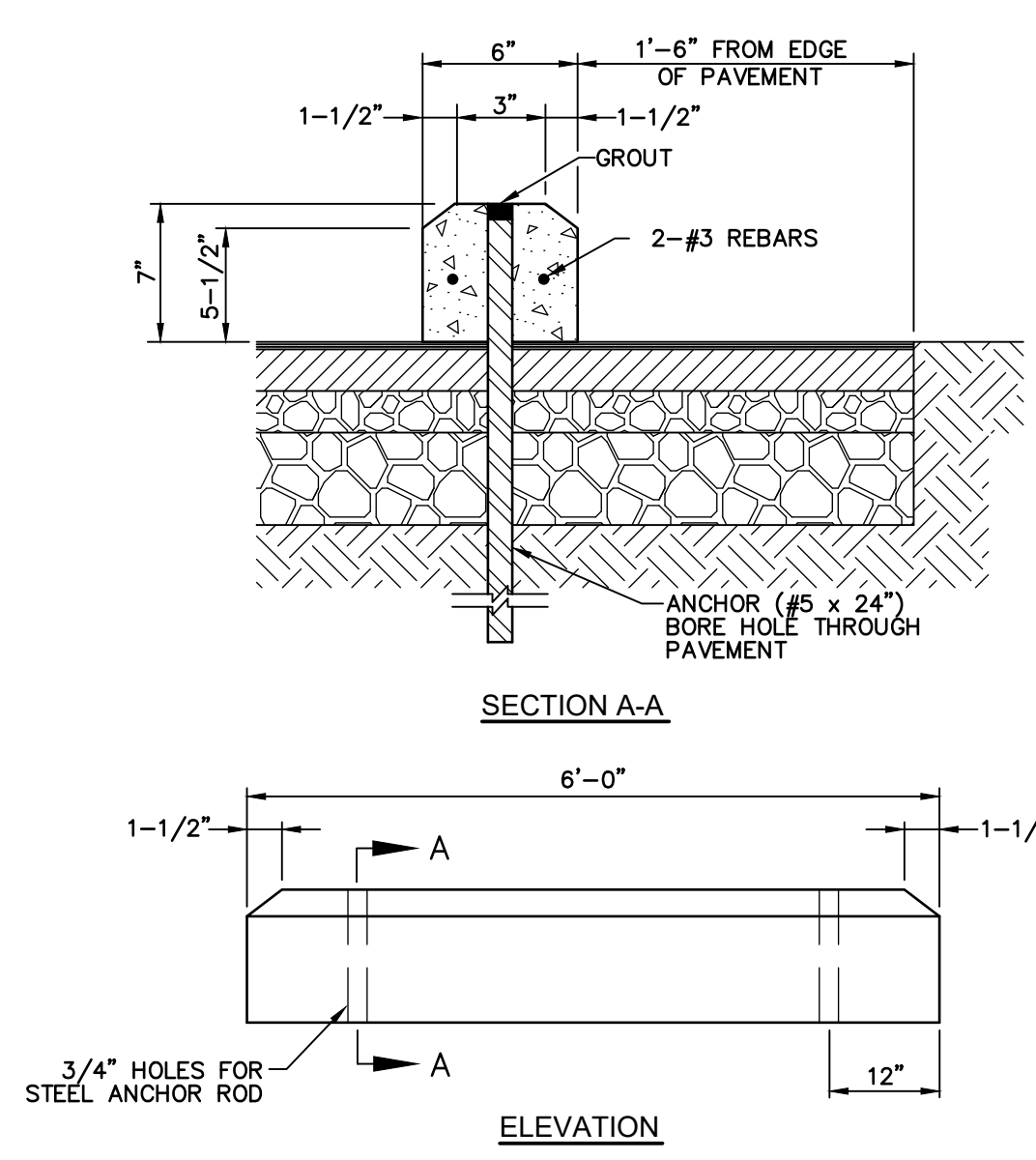
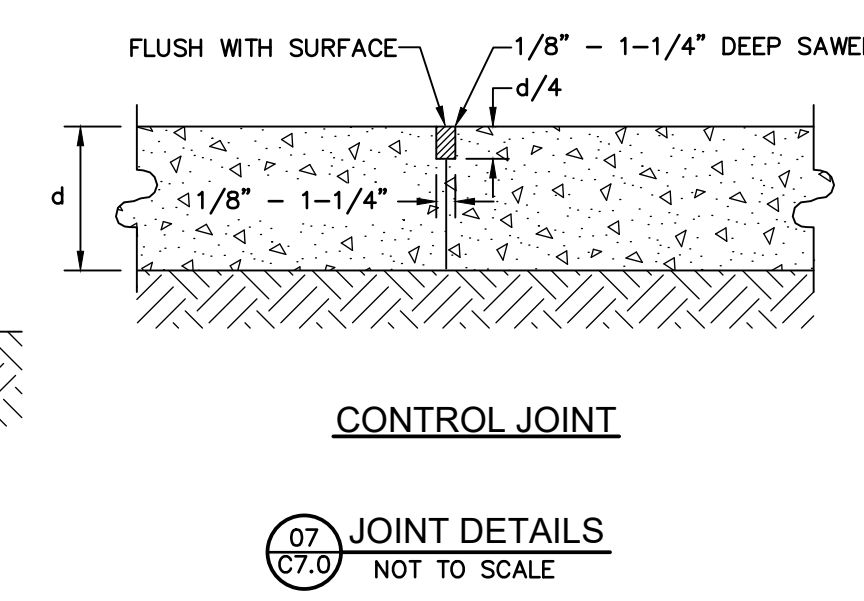
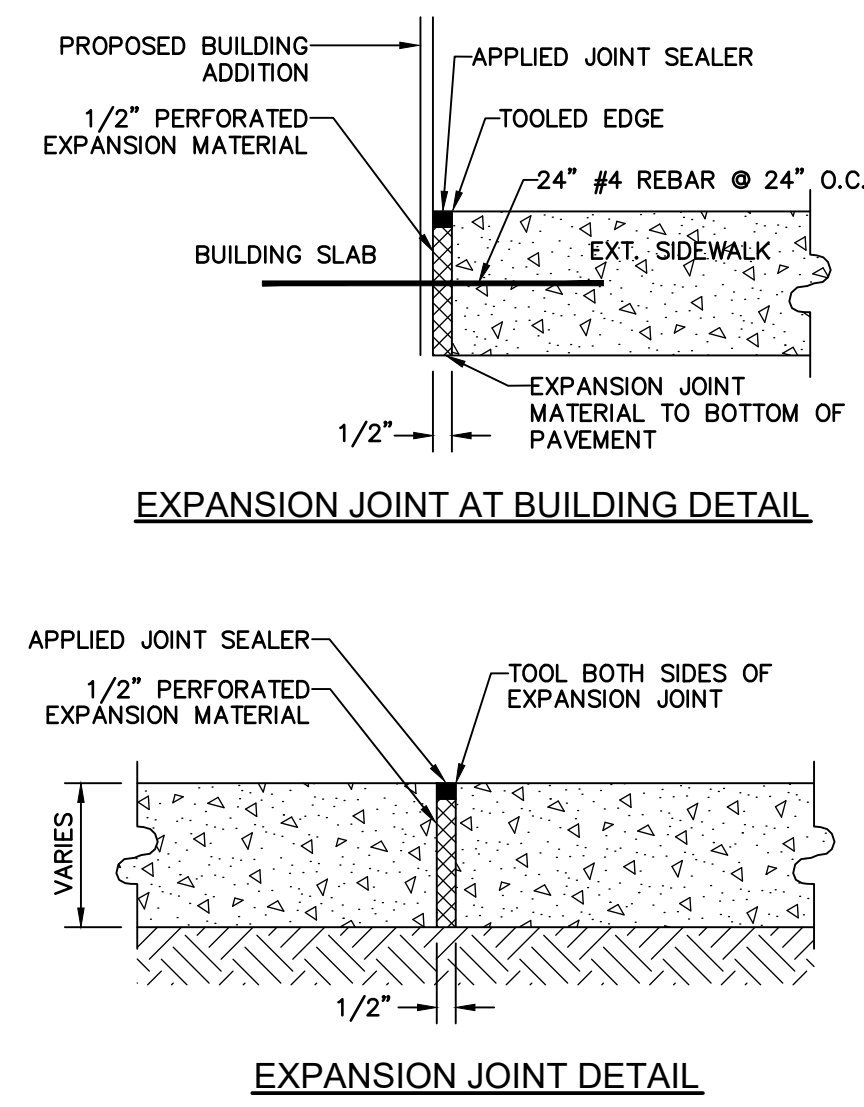

REVISION RECORD				
REV	DATE	DESCRIPTION	DES BY	APP BY

**BDC REALTY GROUP, LLC**  
6274 S FOX CHASE  
PENTLETON, IN 46064

**CIVIL SITE GROUP, INC.**  
718 Adams Street, Suite E  
Carmel, Indiana 46032  
Ph: (317) 810-1677

**BRIAN S. CROSS**  
REGISTERED PROFESSIONAL ENGINEER  
STATE OF INDIANA  
No. PE10910647  
DATE: 10/02/2025

DWN BY: BSC  
CHKD. BY: BSC  
SCALE: N/A  
DATE: 10/02/25

**SHOPPES at BROOKSIDE - BLOCK A**  
CR 600 W  
McCordsville, IN 46055

**GENERAL DETAILS**  
PHASE III - NORTH BUILDING

PROJECT NUMBER: BRG.008  
DRAWING NUMBER: **C7.0**  
SHEET 9 OF 24



REVISION RECORD				
REV	DATE	DESCRIPTION	DES BY	APP BY
1	11/04/25	TAC REVIEW; FLOWLINES/BENCH WALLS; BMP	BSC	BSC

**STORM SEWER INLET NOTE**

ALL STORM WATER INLETS & CATCH BASIN CASTINGS SHALL BE LABELLED WITH ENVIRONMENTAL MESSAGING "NO DUMPING, DRAINS TO STREAM" CAST IN RAISED OR RECESSED LETTERS AT A MIN. 1-INCH HEIGHT. A SYMBOL OF A FISH SHALL ALSO BE CAST WITH THE LETTERS

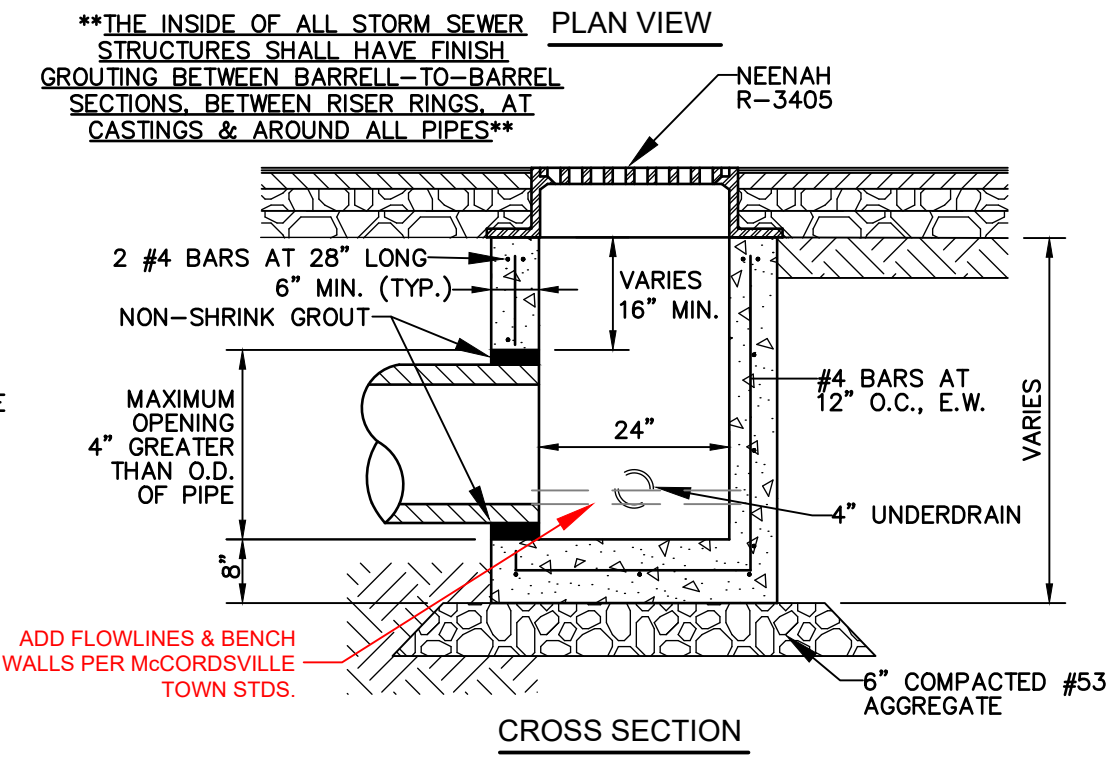
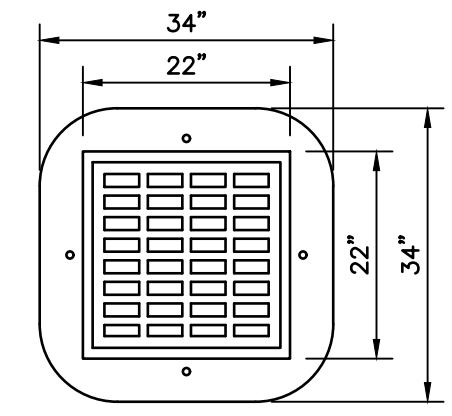
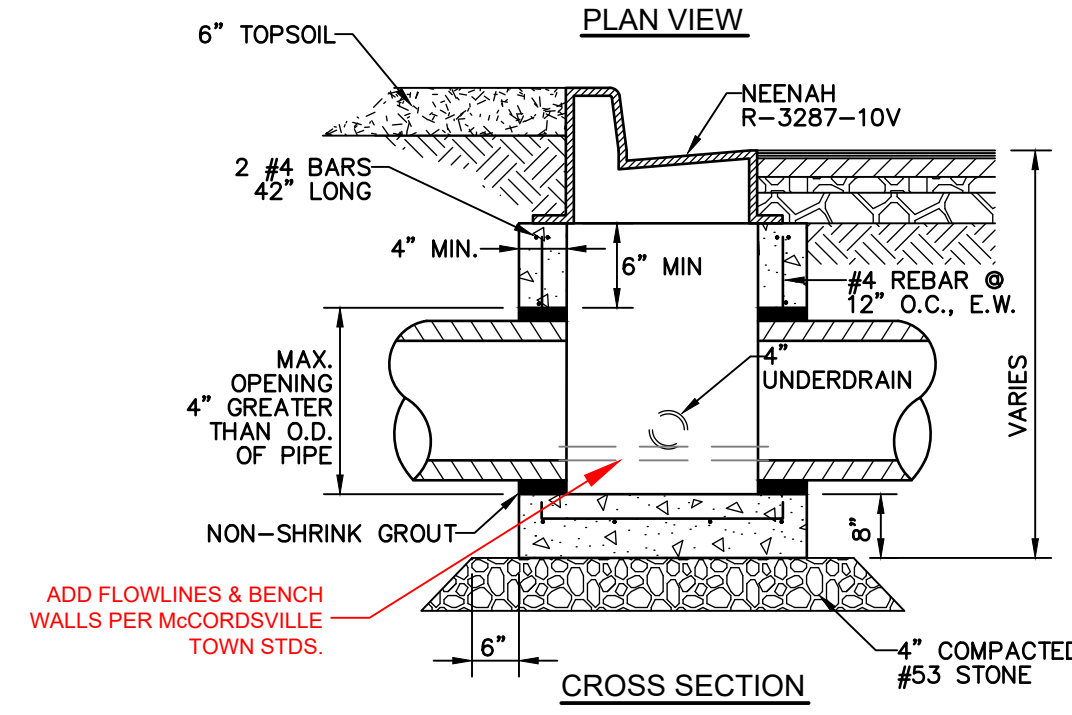
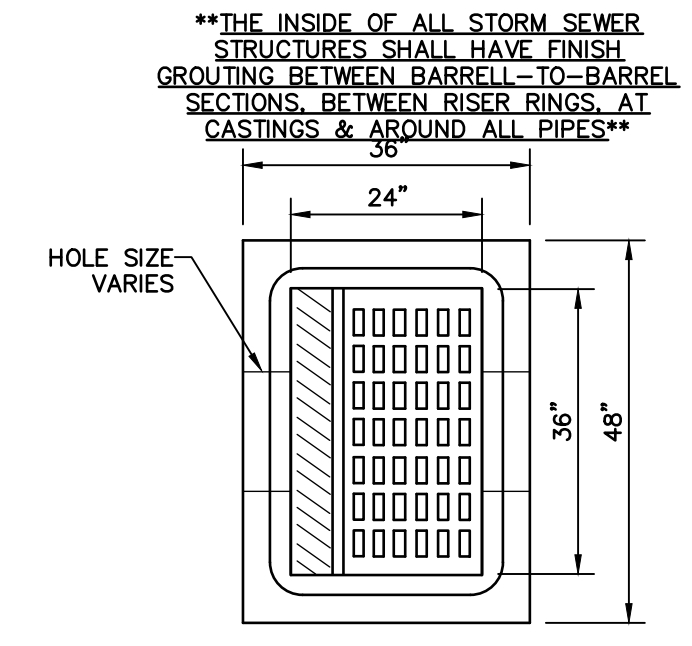

02 C7.1 PAVEMENT INLET TYPE "A" NOT TO SCALE

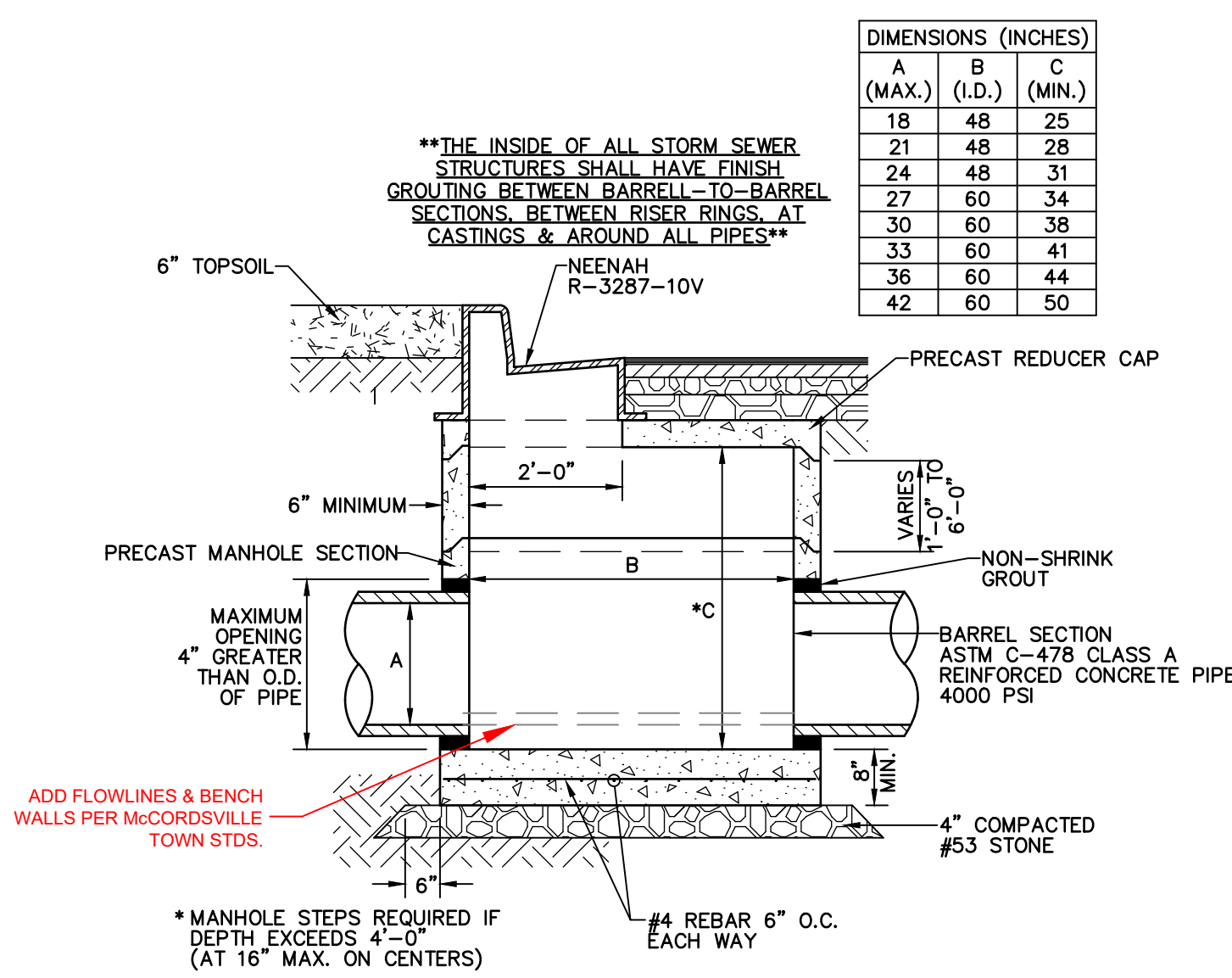

01 C7.1 CURB MANHOLE NOT TO SCALE

DIMENSIONS (INCHES)		
A (MAX.)	B (I.D.)	C (MIN.)
18	48	25
21	48	28
24	48	31
27	60	34
30	60	38
33	60	41
36	60	44
42	60	50

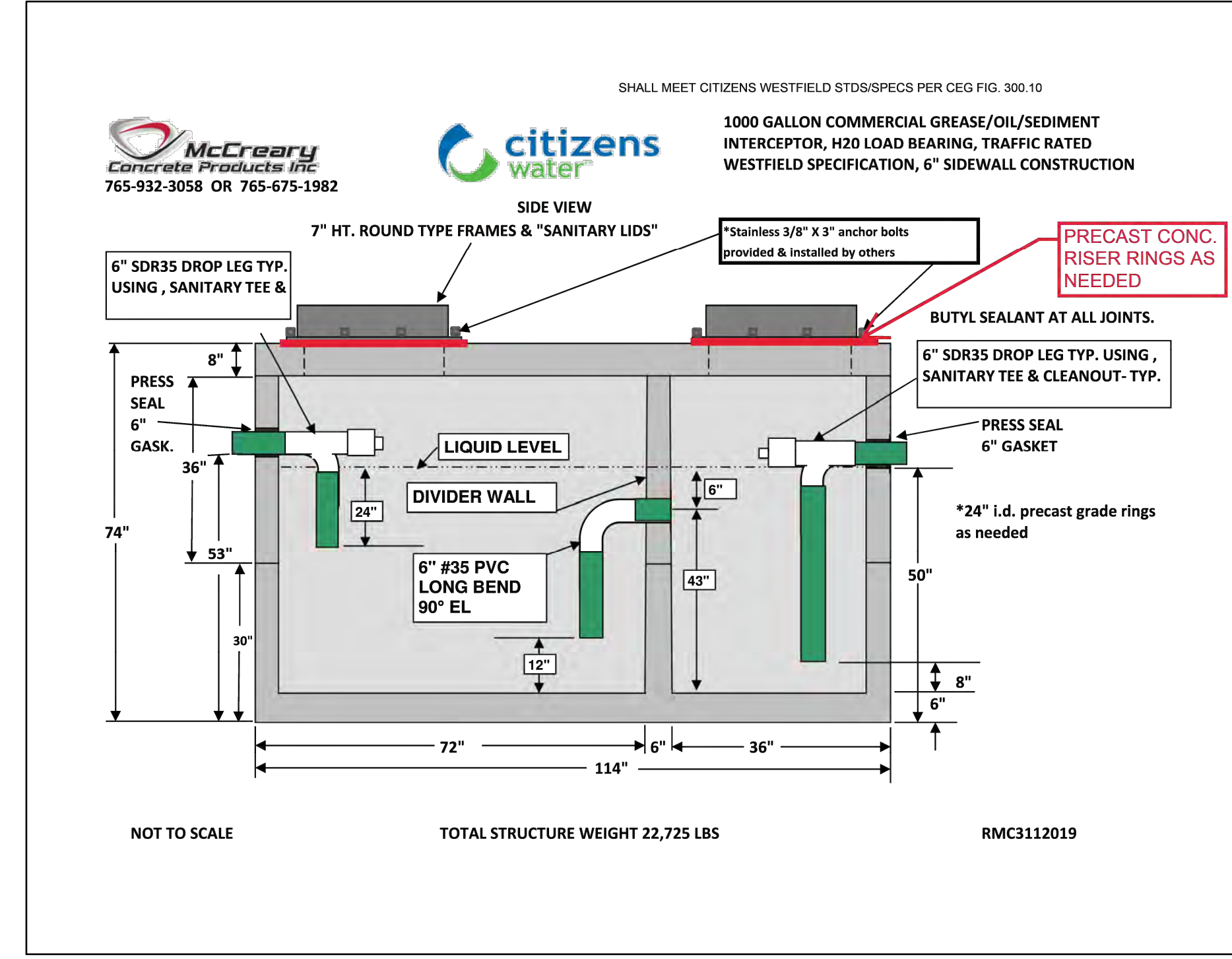

NOT TO SCALE TOTAL STRUCTURE WEIGHT 22,725 LBS RMC3112019

**AQUA SWIRL OFF-LINE ARRANGEMENT**

\*\*\*NOTE: BACKFILL AROUND THE PERIMETER OF THE STRUCTURE SHALL BE "B" BORROW OR EQUIVALENT GRANULAR MATERIAL COMPACTED TO 95% STANDARD PROCTOR DENSITY (INSTALLED IN MAX. 12" LIFTS)\*\*\*

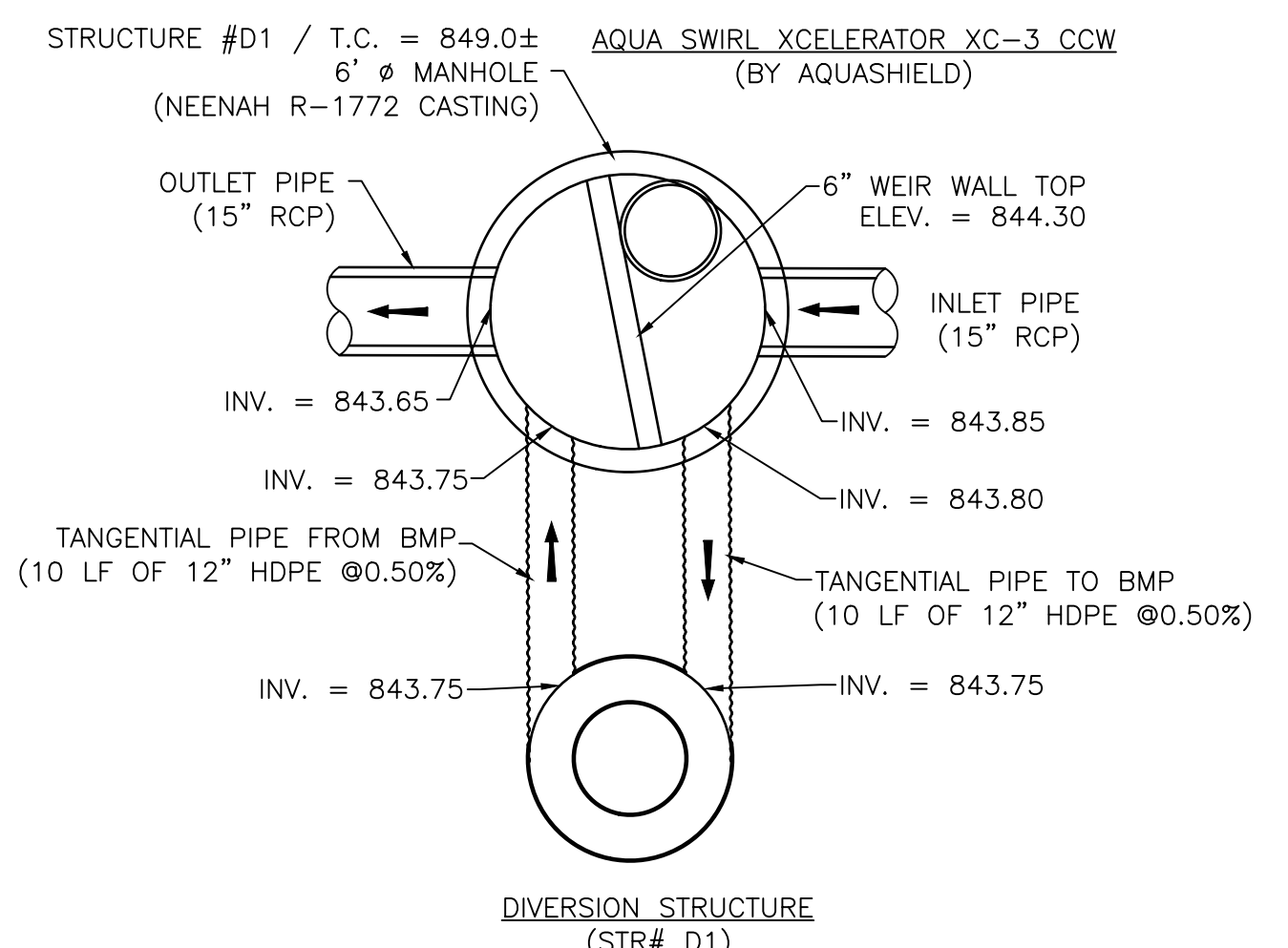

DIVERSION STRUCTURE (STR# D1)

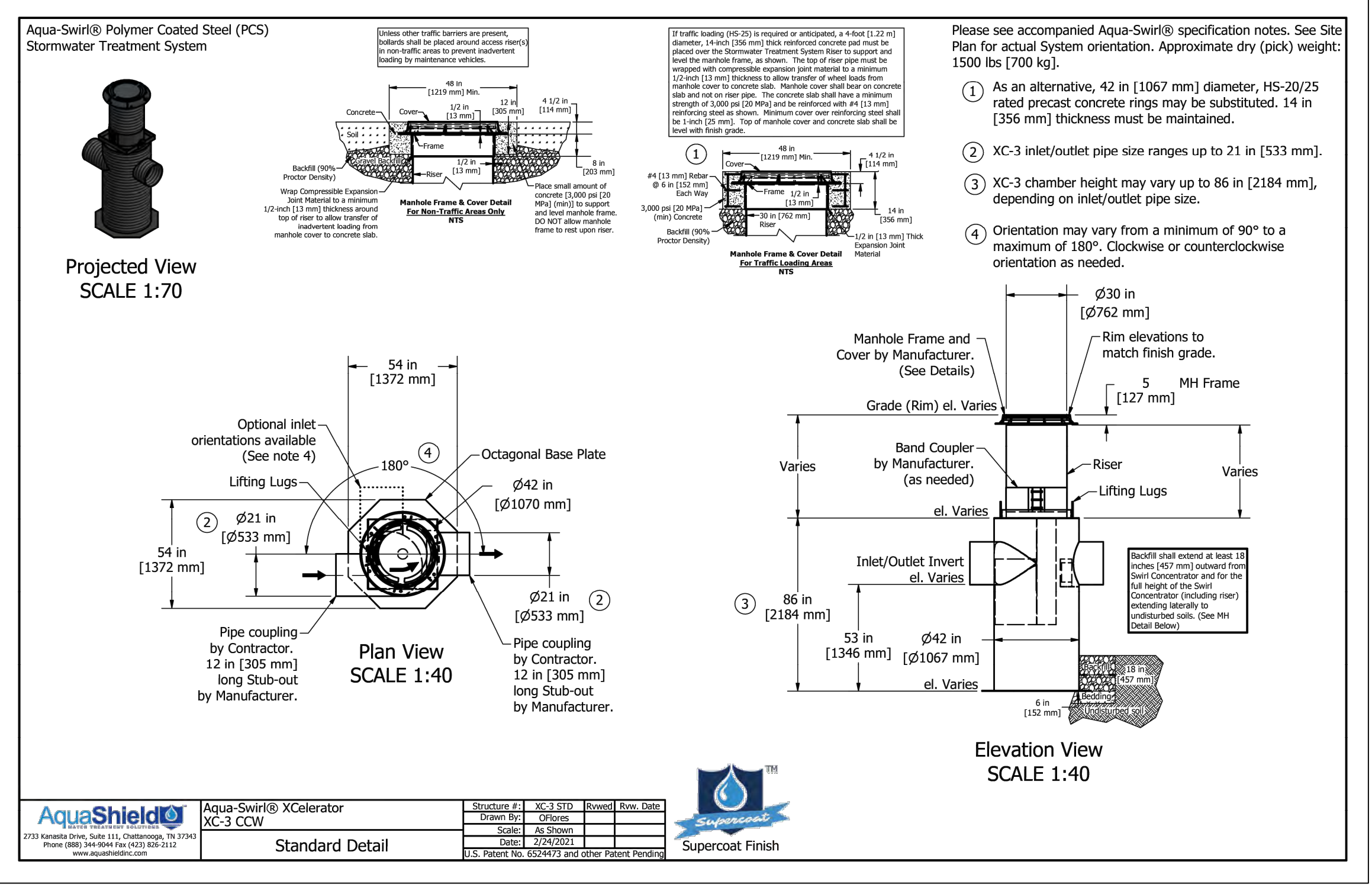

AquaShield®	Aqua-Swirl® Xcelerator XC-3 CCW	Structure #	XC-3 STD	Divided	Flow Depth
2733 Karanda Drive, Suite 111, Chesapeake, VA 23041	Phone 800-544-3444 Fax 757-533-3111	Scale	As Shown		
		Notes	1. As Shown		
			2. As Shown		
			3. As Shown		
			4. As Shown		
			5. As Shown		
			6. As Shown		
			7. As Shown		
			8. As Shown		
			9. As Shown		
			10. As Shown		
			11. As Shown		
			12. As Shown		
			13. As Shown		
			14. As Shown		
			15. As Shown		
			16. As Shown		
			17. As Shown		
			18. As Shown		
			19. As Shown		
			20. As Shown		
			21. As Shown		
			22. As Shown		
			23. As Shown		
			24. As Shown		
			25. As Shown		
			26. As Shown		
			27. As Shown		
			28. As Shown		
			29. As Shown		
			30. As Shown		
			31. As Shown		
			32. As Shown		
			33. As Shown		
			34. As Shown		
			35. As Shown		
			36. As Shown		
			37. As Shown		
			38. As Shown		
			39. As Shown		
			40. As Shown		
			41. As Shown		
			42. As Shown		
			43. As Shown		
			44. As Shown		
			45. As Shown		
			46. As Shown		
			47. As Shown		
			48. As Shown		
			49. As Shown		
			50. As Shown		
			51. As Shown		
			52. As Shown		
			53. As Shown		
			54. As Shown		
			55. As Shown		
			56. As Shown		
			57. As Shown		
			58. As Shown		
			59. As Shown		
			60. As Shown		
			61. As Shown		
			62. As Shown		
			63. As Shown		
			64. As Shown		
			65. As Shown		
			66. As Shown		
			67. As Shown		
			68. As Shown		
			69. As Shown		
			70. As Shown		
			71. As Shown		
			72. As Shown		
			73. As Shown		
			74. As Shown		
			75. As Shown		
			76. As Shown		
			77. As Shown		
			78. As Shown		
			79. As Shown		
			80. As Shown		
			81. As Shown		
			82. As Shown		
			83. As Shown		
			84. As Shown		
			85. As Shown		
			86. As Shown		
			87. As Shown		
			88. As Shown		
			89. As Shown		
			90. As Shown		
			91. As Shown		
			92. As Shown		
			93. As Shown		
			94. As Shown		
			95. As Shown		
			96. As Shown		
			97. As Shown		
			98. As Shown		
			99. As Shown		
			100. As Shown		

BDC REALTY GROUP, LLC  
6274 S FOX CHASE  
PENDLETON, IN 46064

**CIVIL SITE GROUP, INC.**  
718 Adams Street, Suite E  
Carmel, Indiana 46032  
Ph: (317) 810-1677

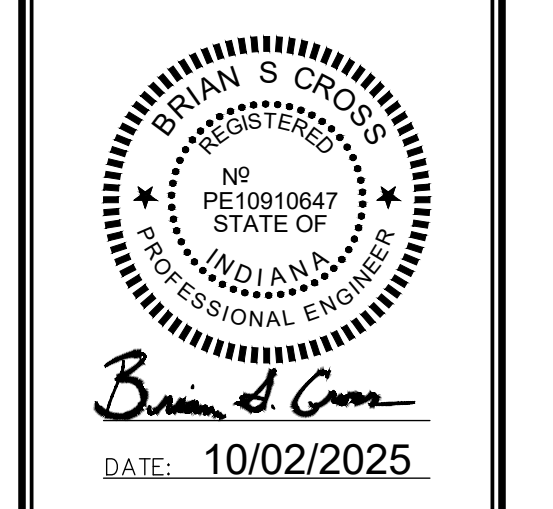

DWN BY: BSC  
CHKD. BY: BSC  
SCALE: N/A  
DATE: 10/02/25

SHOPPES at BROOKSIDE - BLOCK A  
CR 600 W  
McCORDSVILLE, IN 46055

GENERAL DETAILS  
PHASE III - NORTH BUILDING

PROJECT NUMBER  
BRG.008

DRAWING NUMBER  
**C7.1**  
SHEET 10 OF 24

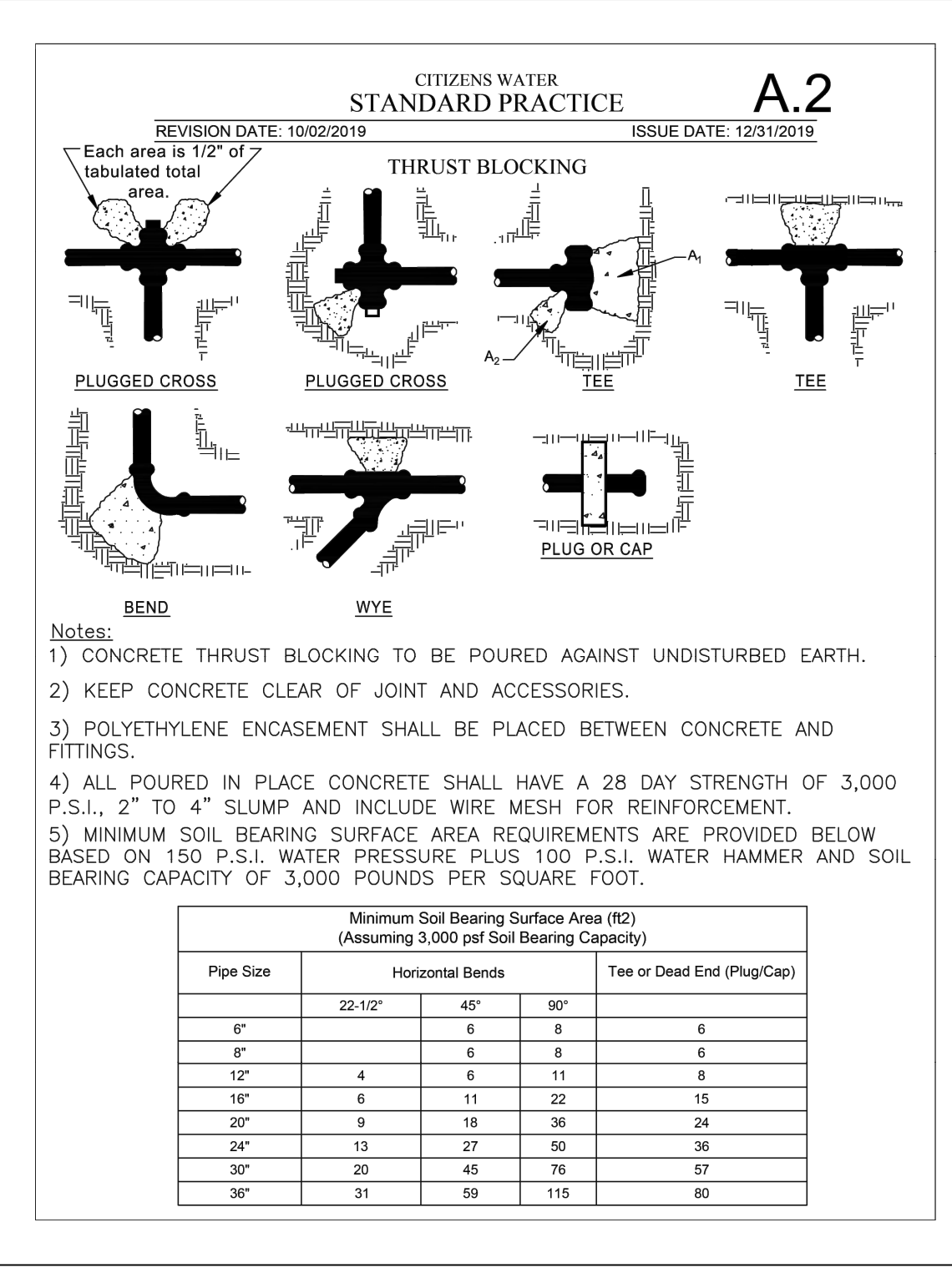
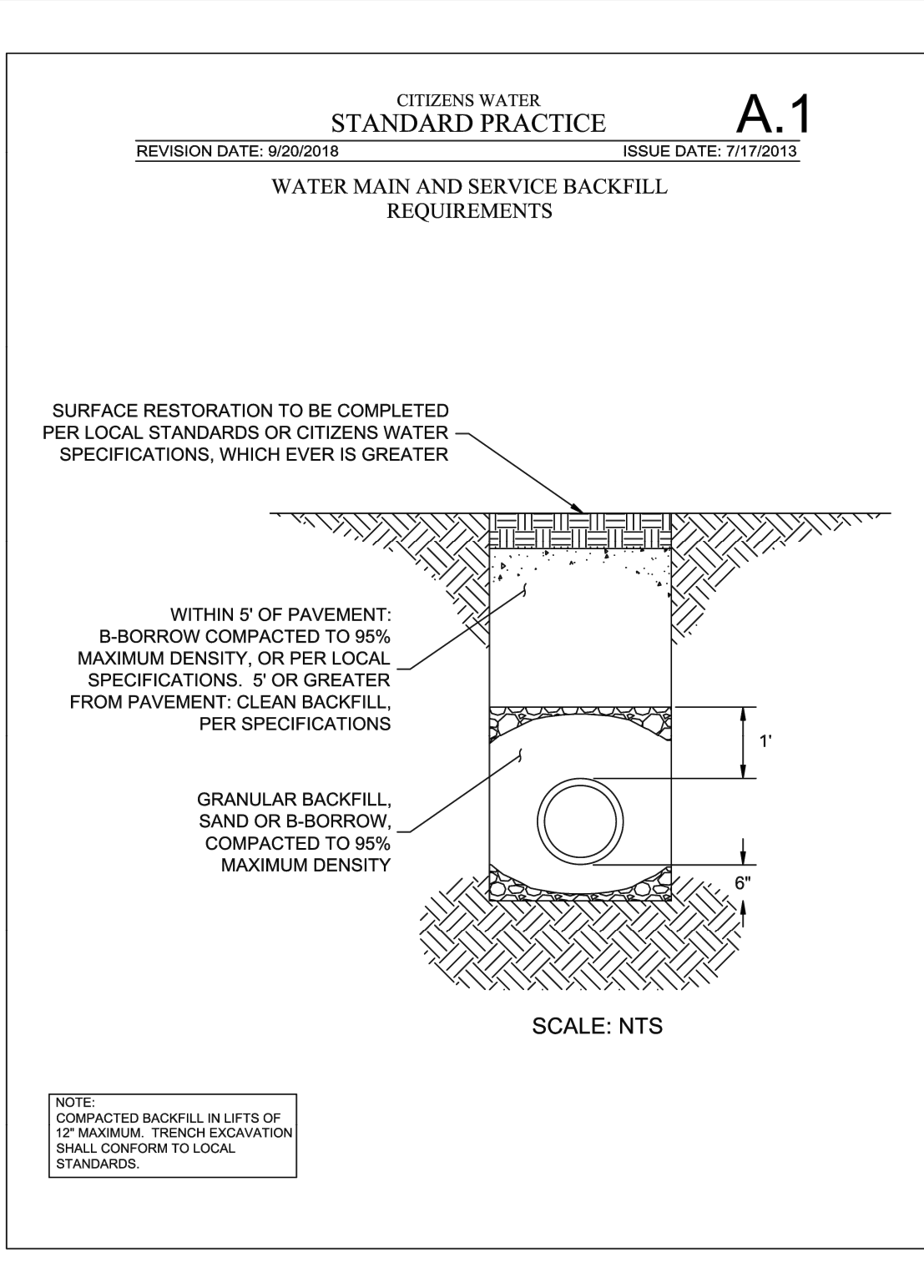
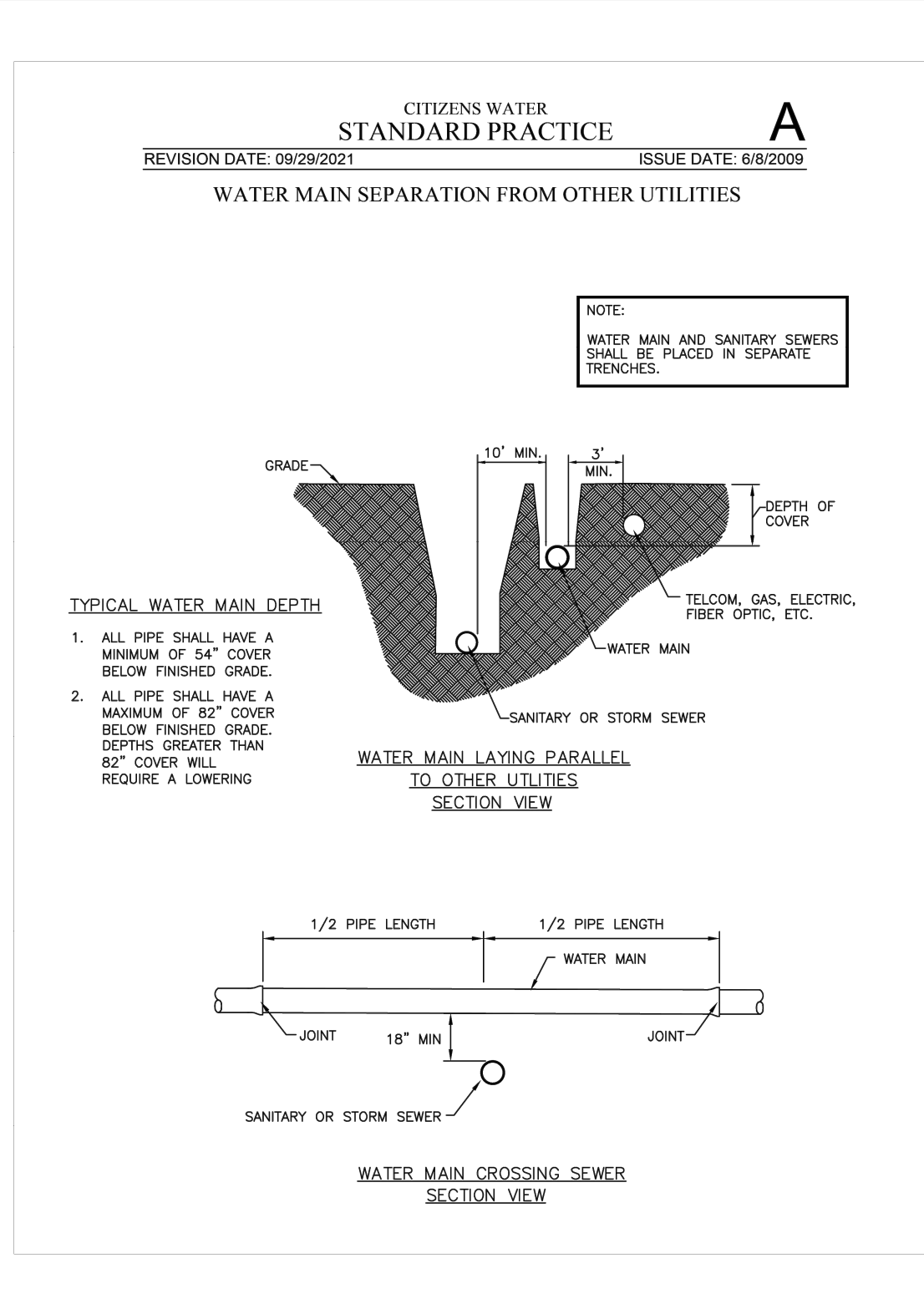

**REVISION RECORD**

REV	DATE	DESCRIPTION	DES BY	APP BY

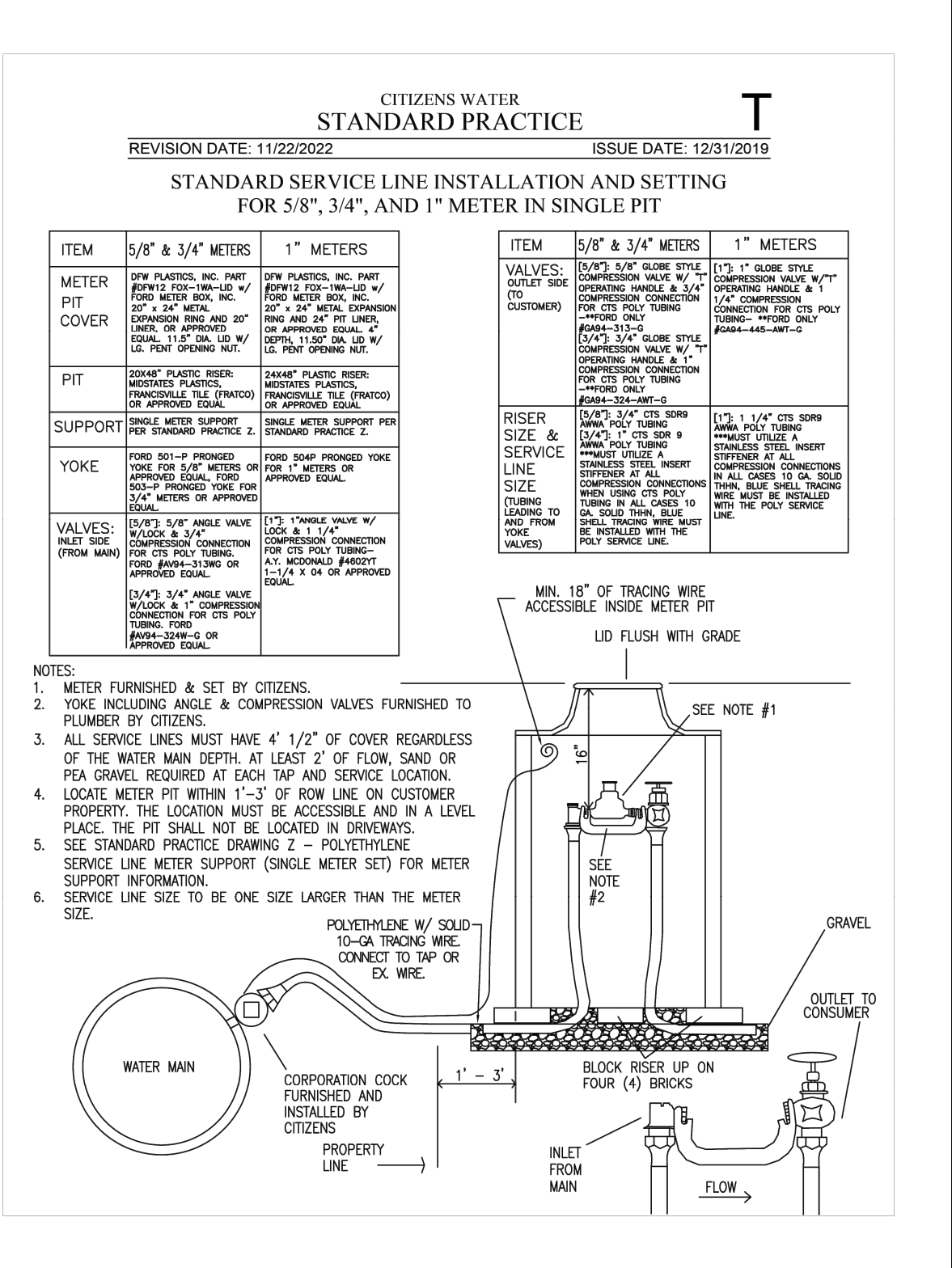
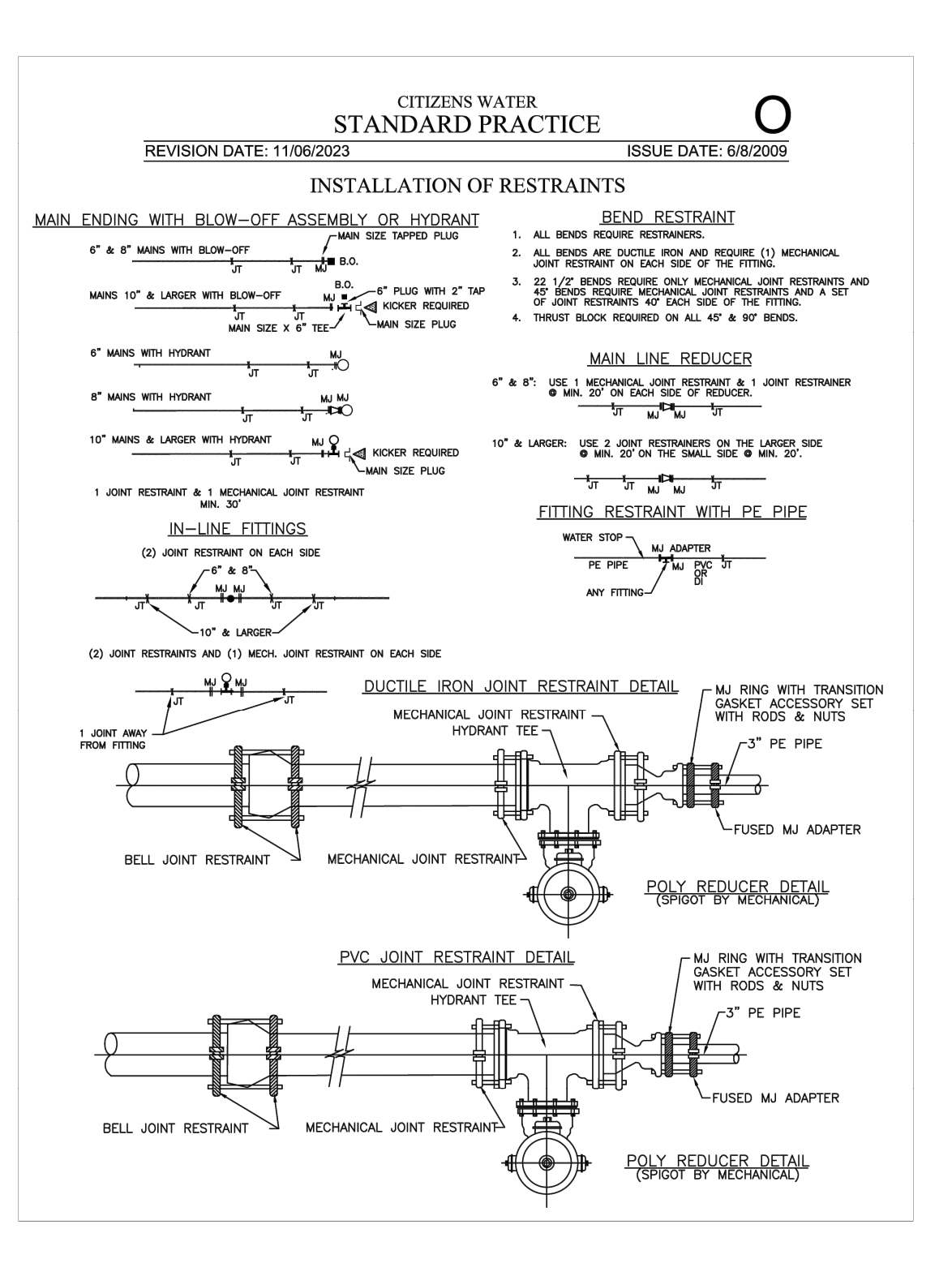
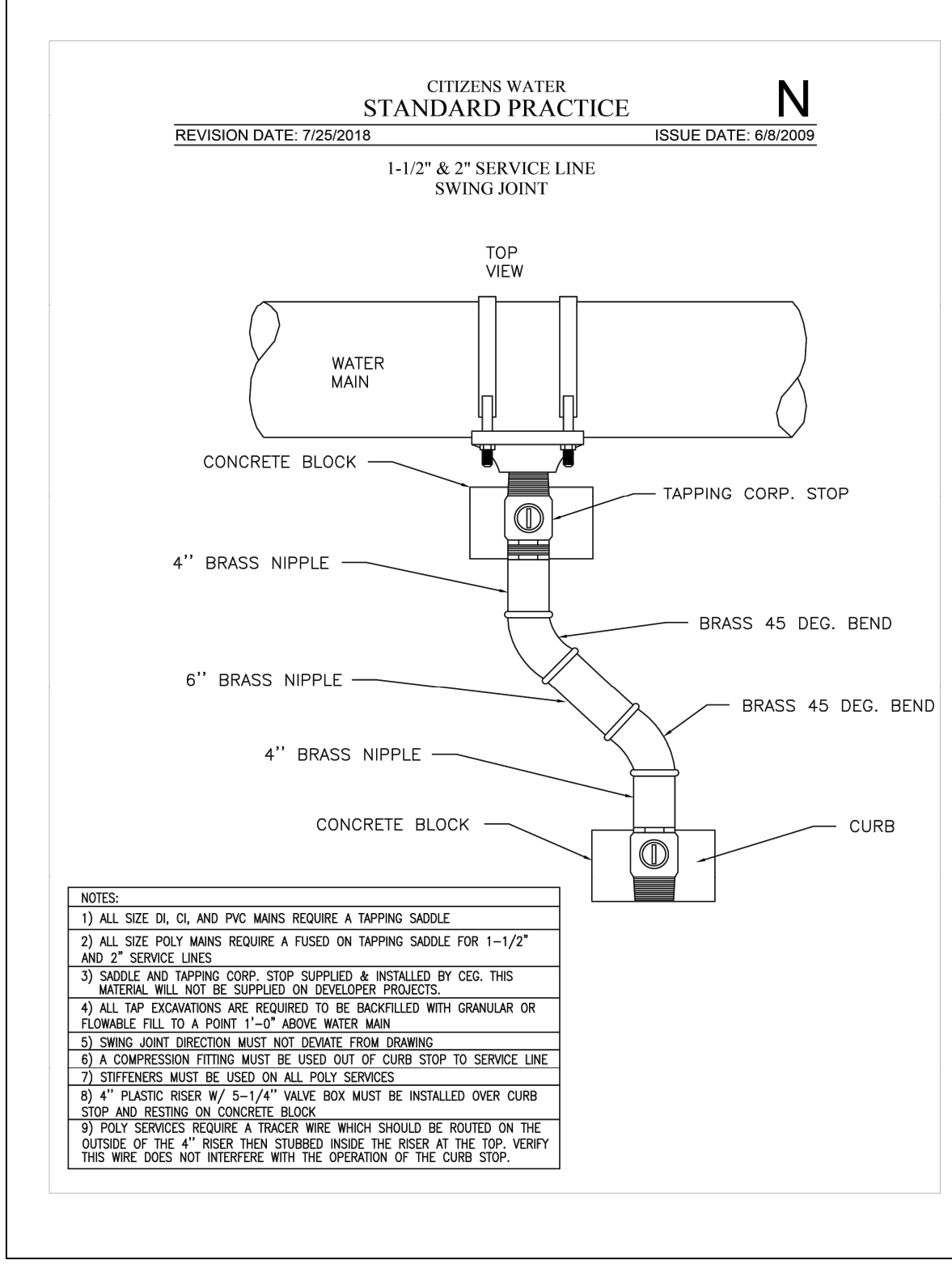

CITIZENS ENERGY GROUP WATER STANDARDS MANUAL, LATEST EDITION (JANUARY 2025), SHALL BE USED FOR ALL WATER SERVICE MATERIALS AND INSTALLATION ASSOCIATED WITH THESE CONSTRUCTION DOCUMENTS

**BDC REALTY GROUP, LLC**  
6274 S FOX CHASE  
PENDLETON, IN 46064

**CIVIL SITE GROUP, INC.**  
718 Adams Street, Suite E  
Carmel, Indiana 46032  
Ph: (317) 810-1677

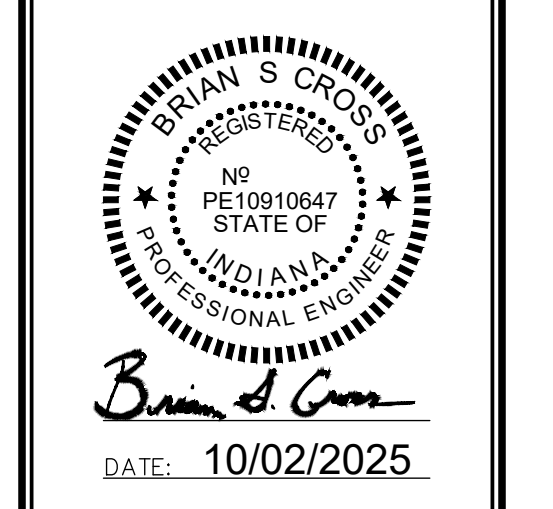

DWN BY: BSC  
CHKD BY: BSC  
SCALE: N/A  
DATE: 10/02/25

SHOPPES at BROOKSIDE - BLOCK A  
CR 600 W  
McCordsville, IN 46055

CITIZENS ENERGY GROUP  
WATER SERVICE DETAILS  
PHASE III - NORTH BUILDING

PROJECT NUMBER  
BRG.008

DRAWING NUMBER  
**C7.2**  
SHEET 11 OF 24



**PLANTING SCHEDULE**

SYMBOL	Quantity	Common Name	Scientific Name
	10	Japanese Zelkova (Min. 2.5" Caliper 6" Above Root Ball)	ZELCOVA SERRATA
	8	CRESENDO MAPLE (Min. 2.5" Caliper 6" Above Root Ball)	ACER SACCHRAUM 'MORTON'
	10	THORNLESS HONEY LOCUST (Min. 2.5" Caliper 6" Above Root Ball)	GLENDISIA TRIACANTHOS
	3	COLUMNAR EUROPEAN HORNBEAM (Min. 2.5" Caliper 6" Above Root Ball; B&B)	CARPINUS BETULUS FASTIGIATA
	74	DENSIFORMIS YEW - MIN. 18" HIGH, 4' O.C.	TAXUS X MEDIA 'DENSIFORMIS'
	46	SPIREA 'CRISP LEAF' - (Min. 18" High, 4' O.C.)	SPIRAEA X BUMALDA 'CRISPA'
	23	"GREEN VELVET BOXWOOD" (Min. 18" Height)	BUXUS x 'Green Velvet'
	13	"DWARF FOUNTAIN GRASS" - 4' O.C.	
	12	RED KNOCKOUT ROSE SHRUB - #3 CONT., 4' O.C.	ROSA - RADRAZZ
	2	Tiny Tuff Stuff (Hydrangea serrata "MAKD" USPP 24,842)	
	N/A	"SEA GREEN" JUNIPER 18" HIGH, 4' O.C. - TYP.	JUNIPERUS CHINENSIS
	15	Assorted "Happy Returns Daylily" and Hemerocallis "Tennessee Volunteer" Daylily	
	4	THUJA OCCIDENTALIS PYRAMIDALIS ARBORVITAE - (Min. 4' Height)	

**SPECIES NOTE**

THE SPECIES OF THE TREES AND SHRUBS SHOWN ON THIS LANDSCAPE PLAN ARE SUBJECT TO CHANGE BASED ON SEASONAL AVAILABILITY. ALL SUBSTITUTIONS WILL BE OF SPECIES APPROVED BY THE TOWN OF PENDELTON.



**LEGEND:**

- APPROX. PROJECT SITE LIMITS
- PARKING LOT PERIMETER (FOR INTERIOR % CALCULATION)
- 2-INCH DEEP HARDWOOD MULCH BED. COLOR SELECTED BY OWNER.
- BUILDING BASE LANDSCAPE RIVER ROCK BED OVER WEED BARRIER. TO BE SELECTED BY OWNER.

**PLAN NOTES:**

- (TR) TRASH ENCLOSURE - SEE ARCHITECTURAL PLAN FOR DETAIL
- (PS) PERMANENT SEED/STRAW MULCH DISTURBED AREAS
- (BR) DERO HOOP BIKE RACK HR-FT-EPX BLACK

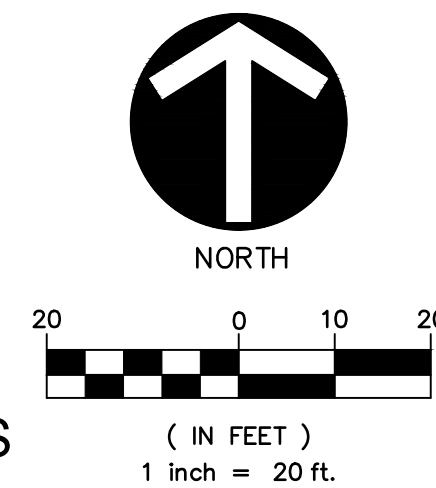

REVISION RECORD				
REV	DATE	DESCRIPTION	DES BY	APP BY
1	11/04/25	TAC REVIEW; BLDG. BASE / D.T. PLANTINGS	BSC	BSC

**IRRIGATION NOTE**

SITE IRRIGATION IS NOT SHOWN ON THESE PLANS. IF SITE IRRIGATION IS REQUIRED, CONTRACTOR SHALL WORK WITH THE LOCAL WATER UTILITY TO DETERMINE THE REQUIREMENTS & LOCATION FOR THE IRRIGATION METER & SITE IRRIGATION SYSTEM.

**LANDSCAPE NOTE**

ALL LANDSCAPING SHALL BE IN ACCORDANCE WITH THE TOWN OF MCCORDSVILLE ZONING ORDINANCE. THE MINIMUM LANDSCAPING IMPROVEMENTS ARE SUBJECT TO FINAL INSPECTION.

**TOWN OF MCCORDSVILLE STANDARDS**

CONTRACTOR TO CONSTRUCT ALL APPLICABLE SITE IMPROVEMENTS TO THE TOWN OF MCCORDSVILLE CURRENT STANDARDS PER THE ATTACHED STANDARD DETAIL SHEETS.

**NOTE**

REFER TO ARCHITECTURAL & FOUNDATION PLANS FOR ALL BUILDING DIMENSIONS.

**LANDSCAPE CALCULATIONS**

<b>PARKING PERIMETER:</b>	
SOUTH LENGTH:	127 FT
TREES REQ'D:	3 (1 TREE PER 50LF)
TREES PROVIDED:	3
<b>NORTH LENGTH:</b>	
TREES REQ'D:	184 FT
TREES PROVIDED:	4 (1 TREE PER 50LF)
<b>WEST LENGTH:</b>	
TREES REQ'D:	50 FT
TREES PROVIDED:	1 (1 TREE PER 50LF)
<b>PARKING:</b>	
INTERIOR PARKING AREA:	21,402 S.F.
LANDSCAPE AREA REQ'D:	1,071 S.F. (5%)
LANDSCAPE AREA PROVIDED:	1,127 S.F. (5.27%)
TREES REQ'D:	3 (1 TREE PER 2,400 SF PKG AREA)
PARKING SPACE AREA:	5,643 S.F.
TREES PROVIDED:	5
SHRUBS REQ'D:	12 (1 SHRUB PER 500 SF PKG AREA)
SHRUBS PROVIDED:	12
<b>BUFFER YARD (WEST):</b>	
BUFFER LENGTH:	142 FT
TREES REQ'D:	10 (7 TREES PER 100LF)
TREES PROVIDED:	12
SHRUBS REQ'D:	15 (10 SHRUBS PER 100LF)
SHRUBS PROVIDED:	16
<b>STREET FRONTAGE (OVERLAY):</b>	
LENGTH:	142 FT
TREES REQ'D:	3 (1 TREE PER 50LF)
TREES PROVIDED:	3

**EXISTING CONDITIONS NOTE**

CONTRACTOR TO VERIFY ALL EXISTING CONDITIONS, INCLUDING UTILITIES AND DRAINAGE INFRASTRUCTURE BEFORE COMMENCING WITH CONSTRUCTION. CONTRACTOR TO NOTIFY ENGINEER OF ANY DISCREPANCIES.

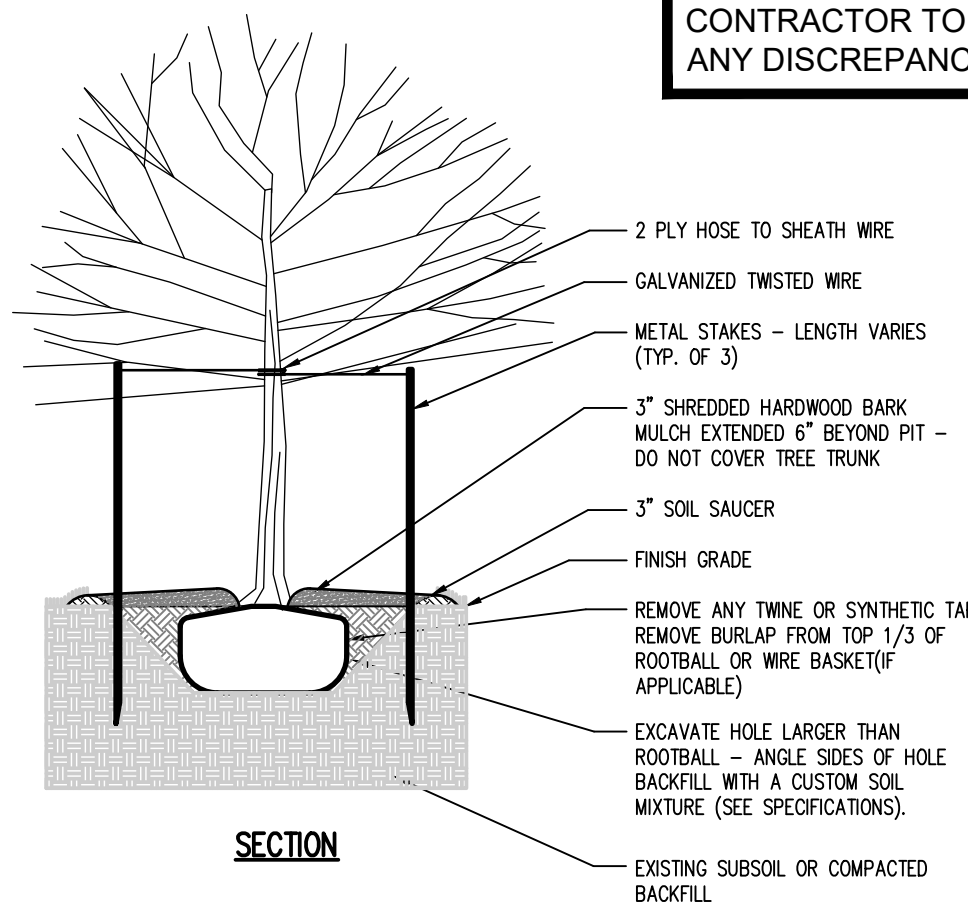

**DECIDUOUS TREE DETAIL**

SCALE: NOT TO SCALE

**LANDSCAPE NOTES:**

All species of plant materials and substitutions thereof are subject to acceptance by the Town of McCordsville Planning Department and approval of the Owner(s) or a representative of the Owner(s).  
 All plant materials are to be warranted for a period of no less than one year from final acceptance by the Owner(s) or a representative of the Owner(s).  
 All plant material is to be planted in a manner that ensures its survival. Any environmental or other type of situation that is noted by the landscape Contractor that could potentially injure the plant or shorten its longevity is to be made known to the Owner(s) and potential substitutions or corrections to the situation can be made at no expense to the Contractor.  
 All materials failing the one year warranty period are to be replaced at the expense of the Landscape Contractor.  
 Any deviation from responsible landscape practices and the Town of McCordsville Ordinances will result in the immediate termination of the Landscape Contract and the Contractor will pay all costs associated with the corrections.  
 All plant material is to come from respectable sources within 100 miles of the site on which it is being installed. If no source for a plant species or acceptable substitute is available within this area, the project Landscape Architect/Engineer is to be notified immediately to make a determination of possible options.  
 All plant material is subject to approval by the project Landscape Architect/Engineer prior to installation and may be rejected for reasons of health, aesthetics, size or other reasonable causes.  
 The Landscape Contractor is responsible for the timely installation of all material in his contract. Should there be a delay due to weather or other unforeseeable, natural circumstances, the timeline will be adjusted.  
 IRRIGATION CONTRACTOR IS RESPONSIBLE TO SUPPLY WATER METER PIT, SERVICE TAPS AT PUBLIC MAIN, AND ALL APPURTENANCES REQUIRED BY THE WATER SERVICE PROVIDER.

**TOPOGRAPHIC & BOUNDARY NOTE**

ALL EXISTING HORIZONTAL AND VERTICAL INFORMATION HAS BEEN SHOWN PER A TOPOGRAPHIC SURVEY DATED 03/11/2024 PREPARED BY CROSSROAD ENGINEERS, P.C.; THEREFORE, CIVIL SITE GROUP, INC. CANNOT BE HELD RESPONSIBLE IF ACTUAL HORIZONTAL AND VERTICAL DATA IS DIFFERENT FROM THAT SHOWN ON THESE PLANS. CONTRACTOR IS RESPONSIBLE FOR FIELD VERIFICATION OF ALL EXISTING CONDITIONS PRIOR TO COMMENCING WITH CONSTRUCTION.

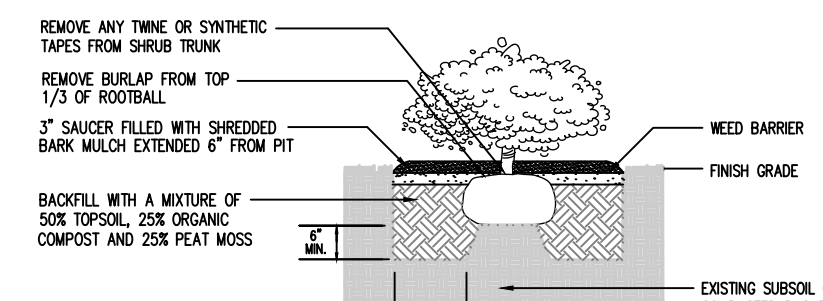

**SHRUB DETAIL**

SCALE: NOT TO SCALE

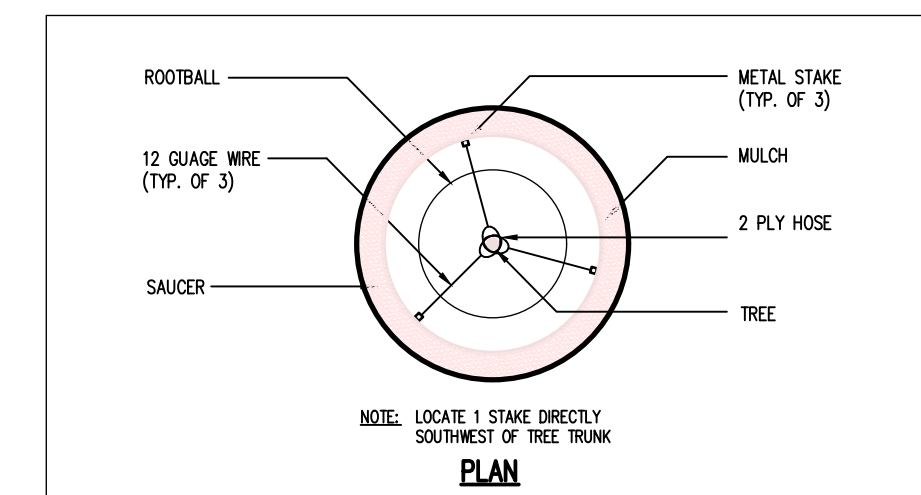

**TREE STAKING DETAIL**

SCALE: NOT TO SCALE

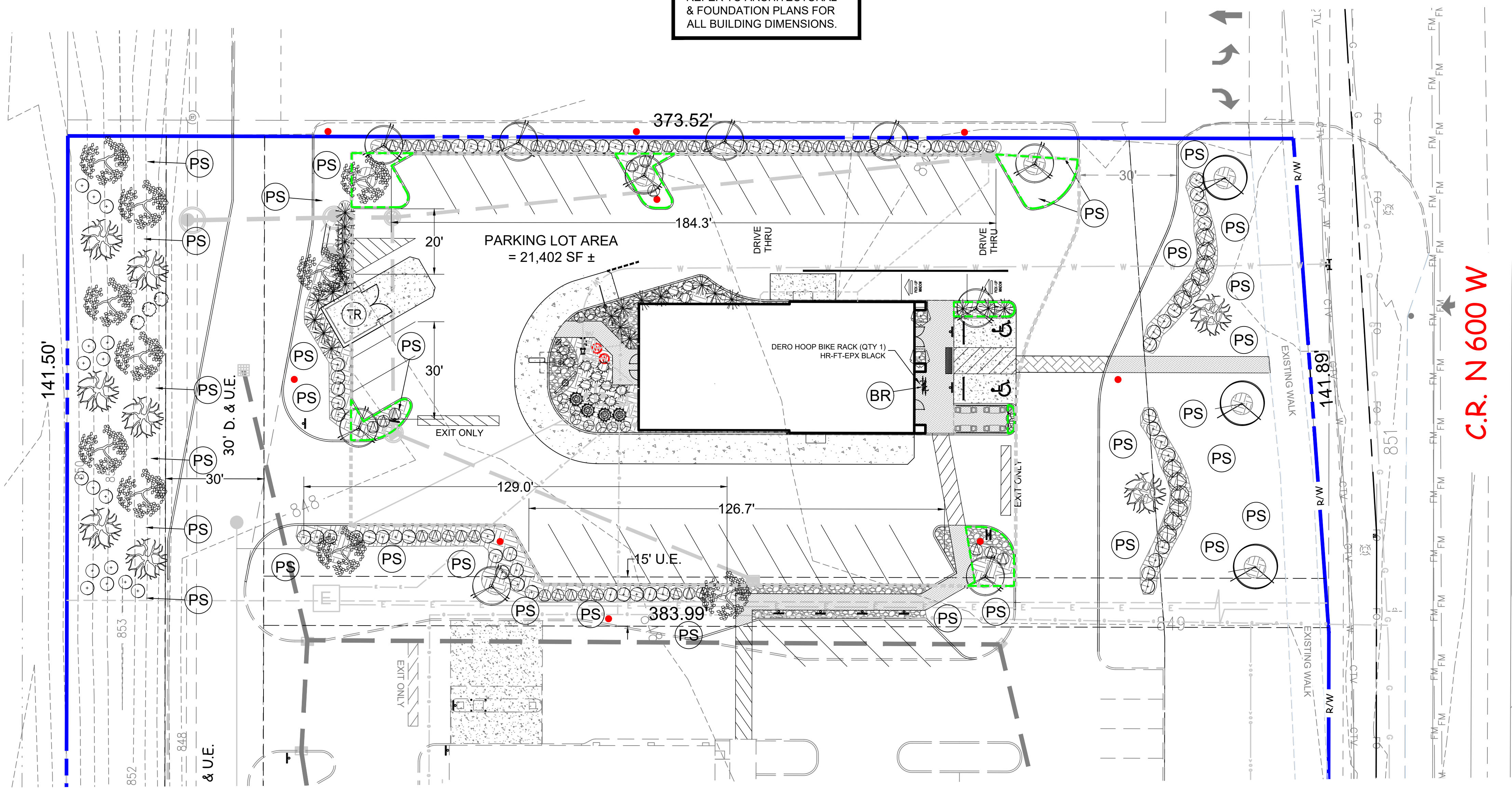

BDC REALTY GROUP, LLC  
 6274 S FOX CHASE  
 PENDELTON, IN 46064

CIVIL SITE GROUP, INC.  
 718 Adams Street, Suite E  
 Carmel, Indiana 46032  
 Ph: (317) 810-1677

BRIAN S. CROSS  
 REGISTERED PROFESSIONAL ENGINEER  
 NO. PE10910647  
 STATE OF INDIANA  
 Brian S. Cross  
 DATE: 10/02/2025

DWN BY:	BSC
CHKD. BY:	BSC
SCALE:	1"=20'
DATE:	10/02/25

SHOPPES at BROOKSIDE - BLOCK A  
 CR 600 W  
 MCCORDSVILLE, IN 46055

LANDSCAPE PLAN  
 PHASE III - NORTH BUILDING

PROJECT NUMBER  
**BRG.008**

DRAWING NUMBER  
**L1.0**  
 SHEET 13 OF 24

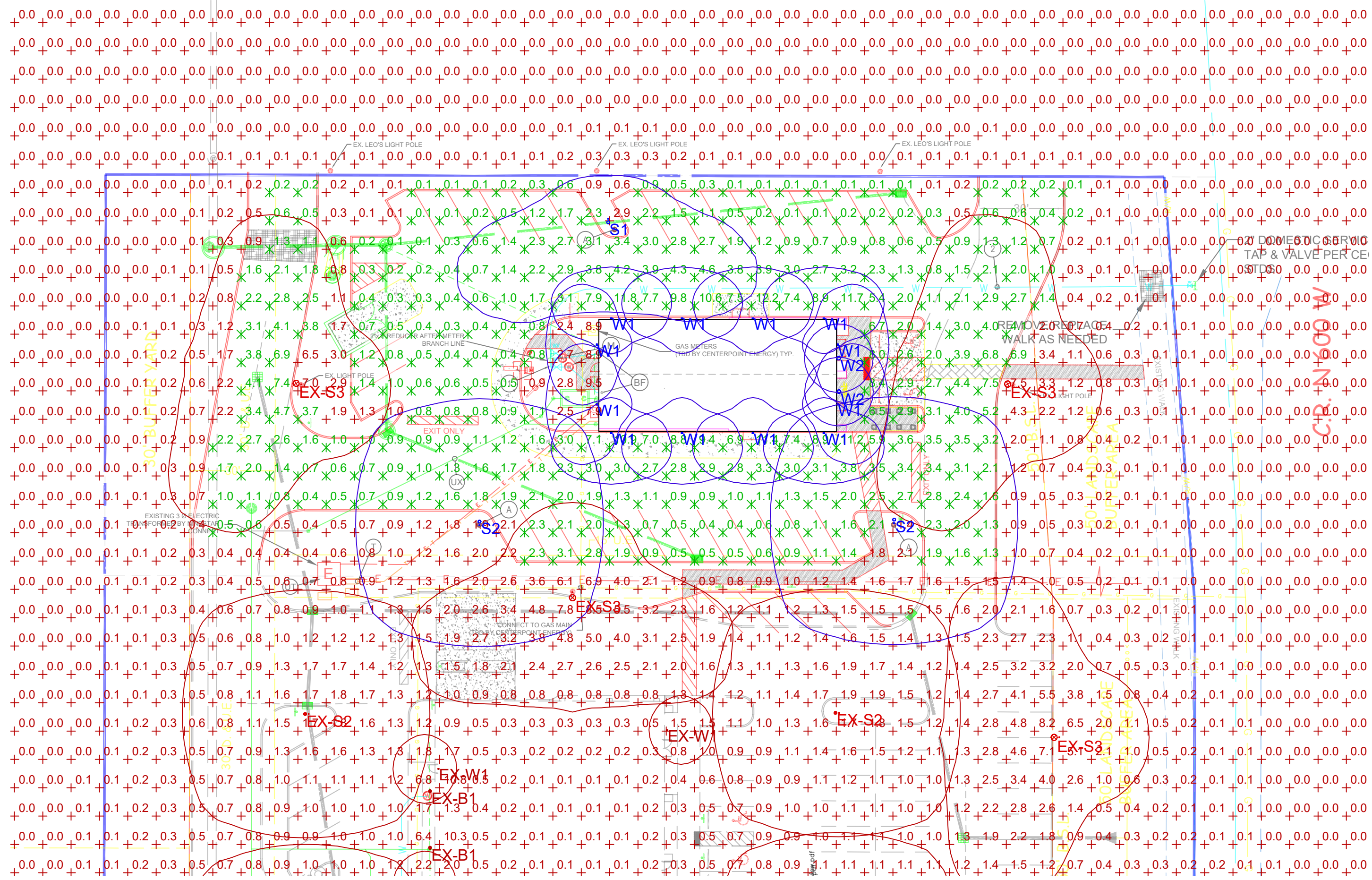

LIGHTING PHOTOMETRIC  
SCALE : 1/32" = 1FT

Statistics						
Description	Symbol	Avg	Max	Min	Max/Min	Avg/Min
Paved Areas_Grade	⌘	2.3 fc	12.2 fc	0.1 fc	122.0:1	23.0:1
Site_Grade	+	1.0 fc	12.2 fc	0.0 fc	N/A	N/A

Schedule								
Symbol	Label	QTY	Manufacturer	Catalog Number	Description	Lumens per Lamp	LLF	Wattage
⌘	EX-B1	6	Lithonia Lighting	KB48 LED 12C 350 40K ASY MVOLT	KB48 WITH 3 LIGHT BOARDS (12 LEDs), 350MA DRIVER, 4000K COLOR TEMP, AND ASYMMETRIC OPTIC	1210	0.95	16
⊗	EX-S2	9	EXISTING	EXISTING	EXISTING	9721	0.95	65.52
⊗	EX-S3	5	Lumenpulse	ALG-120277-CSL-L170-40K-CRI 80-3	Alliegra	14729	0.95	146
⊗	EX-W1	6	Lithonia Lighting	WPX0 LED ALO-1 40K MVOLT	WPX0 LED, 850 Lumen setting, 4000K Setting, 120-277V	829	0.95	6.0096
○	S1	1	Visionaire Lighting LLC	ODN1-TS-10L-3K-UNV-CLS MOUNTED AT 20'	ODEN 1 ARRAY 10000 LUMENS T3 CUTOFF LOUVER SHIELD 65W	7601	0.95	65.52
○	S2	2	Visionaire Lighting LLC	ODN1-TLS-10L-3K-UNV-CLS MOUNTED AT 20'	ODEN 1 ARRAY 10000 LUMENS T5LS CUTOFF LOUVER SHIELD 65W	9721	0.95	65.52
□	W1	12	EELP, Inc.	WPS3-E-40L-QT-40K-T3	Formed black metal housing - MOUNTED AT 16'-0" AFG	4614	0.95	40.9964
○	W2	2	America Nail Plate	WS16M016LDMW40K	WS16 16" WAREHOUSE SHADE, 16W CREE LED Module - Dome Lens, 4000K CCT - MOUNTED AT 16'-0" AFG	1852	0.95	17.45

Disclaimer: This lighting submittal is strictly based on the information provided by the manufacturer, and is provided without warranty as to accuracy, completeness, reliability or otherwise. If the information (including but not limited to floor plans, reflected ceiling plans, electrical plans and specifications) provided to LightSource Inc. is inaccurate or incomplete, or if the information is a false statement, the accuracy of proposed design may be adversely affected. Once this lighting submittal is received by the customer or end-user, the customer is the obligor of the installation and shall be responsible to consult with a professional engineering advisor to determine whether the proposed design meets the applicable project requirements for lighting system performance, code compliance, safety, suitability and effectiveness for use in a particular application. In no event will LightSource be responsible for any loss resulting from any use of any information contained in this lighting submittal.

**GENERAL NOTES**

- GENERAL PLAN NOTES:**
- MH: AS NOTED
  - POINTS CALCULATED AT: GRADE
  - LIGHT LOSS FACTOR: AS NOTED

No.	Revision/Issue	Date

**LightSource**  
THE LIGHTING & CONTROL EXPERTS

8719 CASTLE PARK DRIVE  
INDIANAPOLIS, IN 46256  
WWW.LIGHTSOURCEINDIANA.COM  
p:317-598-6900

**VILLAGES AT  
BROOKSIDE - PHASE  
II- SOUTH BUILDING**

**EXTERIOR LIGHTING PHOTOMETRIC**

Drawn By	ARH
Scale	As Noted
Date	10/13/2025
Drawing #	LS-25-2281 SITE
Sheet No.	<b>E101</b>

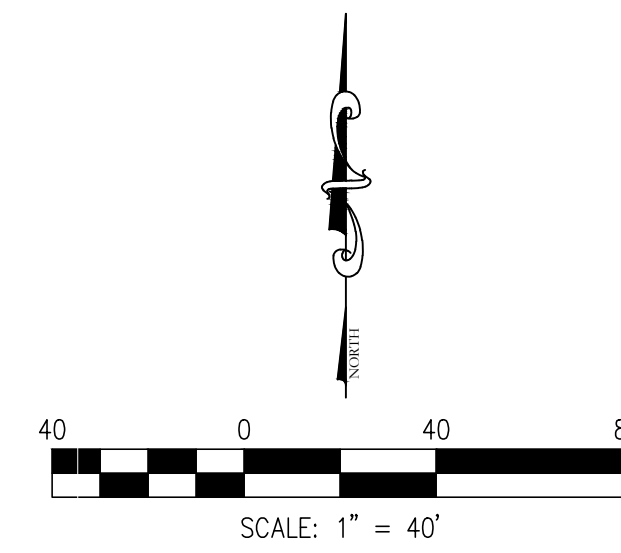
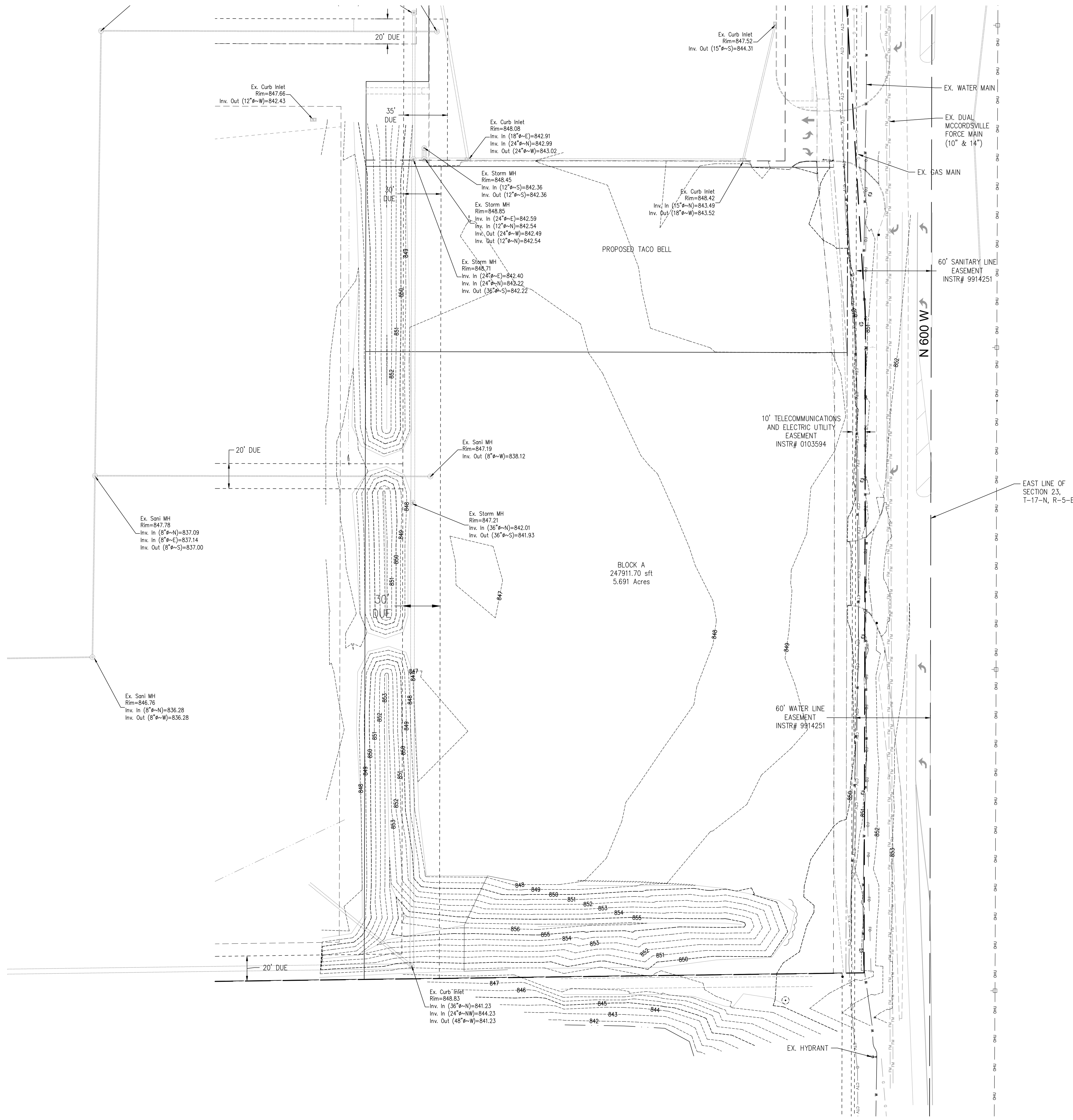

**TOPOGRAPHICAL NOTES**

1. THIS IS NOT A BOUNDARY SURVEY.
2. UTILITIES ARE GRAPHICAL REPRESENTATION PER SURVEY AND MAPPING.
3. EXISTING INFORMATION ON LOT 1, BLOCK A REFLECTS DESIGN INFORMATION PER PLANS DATED FEBRUARY 19, 2021 WITH A LATEST REVISION DATE OF MAY 14, 2021. ACTUAL IN PLACE ELEVATIONS WILL NEED TO BE CONFIRMED BY CONTRACTOR.

EXISTING UTILITY SIZE AND MATERIAL INFORMATION SHOWN ON THESE PLANS ARE PER THE BEST GRAPHICAL AND VISIBLE INFORMATION AVAILABLE. CONFLICTS MAY EXIST AND IT SHALL BE THE CONTRACTOR'S RESPONSIBILITY TO FIELD VERIFY ALL SIZING AND MATERIAL INFORMATION PROVIDED. IF ACTUAL CONDITIONS DIFFER FROM THAT INFORMATION SHOWN ON THE PLANS, THE CONTRACTOR SHALL, PRIOR TO THE INSTALLATION OF ANY PROPOSED INFRASTRUCTURE, NOTIFY THE DESIGN ENGINEER IMMEDIATELY.

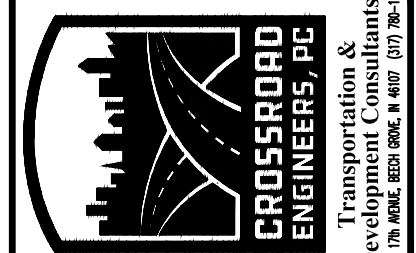

# TOPOGRAPHICAL SURVEY

## BLOCK A

JOB No. :  
 DATE : MARCH 11, 2024  
 DRAWN : KLF  
 CHECKED : GWC  
 DESIGNED :  
 APPR. :

NO.	DATE	REVISIONS	BY	APPR.

# McCordsville, Indiana

## Town Standards

### DIRECTIONS FOR USE

- 1.) The entire set of full size drawings shall be attached to the construction drawings and shall be considered part thereto. A partial set may be used for small projects when whole sections are not applicable. Approval of use of a partial set will be made by the Town Engineer at the time of approval of the construction drawings.
- 2.) Details prepared by outside sources shall not be included in the construction drawings when the said drawings cover work which is covered by McCordsville Standards.
- 3.) Individual McCordsville Standards that do not apply may be crossed out by the design engineer through placement of a single large X over the detail. Minor reference notations may be placed adjacent to individual standard titles for coordination. However, the standards themselves shall not be modified in any way.
- 4.) Details prepared by outside sources covering work which is not covered by the McCordsville Standards are the sole responsibility of the design engineer and shall be placed on sheets other than the McCordsville Standards.





### GENERAL NOTES

- 1.) Contractor shall verify the exact location of all existing utilities at least 48 hours prior to any construction or excavation. All utilities shall be adequately supported to minimize damage. The contractor shall be responsible for repairing damaged utilities to the satisfaction of the Town of McCordsville and the owner of the utility.
- 2.) All benchmarks and elevations shall be from NAD 1983 (Conus) Datum. All coordinates shall conform with the Hancock County GIS standard.
- 3.) Wherever proprietary equipment is specified, all proposals for substitution shall be submitted in writing to the Town Engineer and shall be subject to the findings of the Town Engineer and may be appealed to the Public Works Committee.
- 4.) Whenever trench opening encroaches within 5 feet of an existing or proposed street or sidewalk, "B"-Borrow compacted in accordance with the most recent INDOT standard specifications shall be required. Approved backfill may be used under proposed sidewalks provided sidewalks are constructed six months after backfilling of the trench.
- 5.) Installation of or provisions for installation of all underground utilities (including service laterals) to be placed under pavement areas shall be established prior to the construction of pavements including lime stabilization.

### REVISION LOG

SHEET NO.	SHEET DESCRIPTION	ISSUED	REVISED	REVISED	REVISED	REVISED
SHEET 1	DIRECTIONS FOR USE, GENERAL NOTES & REVISION LOG	06/14/05	05/02/2023			
SHEET 2	RIGHT-OF-WAY SECTIONS & PAVEMENT SPECIFICATIONS	06/14/05	05/02/2023	05/09/2025		
SHEET 3	RIGHT-OF-WAY DETAILS	06/14/05	05/02/2023			
SHEET 4	UTILITY LOCATION GUIDELINES	06/14/05	05/02/2023			
SHEET 5	DRIVE WAYS, SIDEWALKS, AND HANDICAP RAMPS	06/14/05	05/02/2023			
SHEET 6	STORM SEWER STRUCTURE DETAILS	06/14/05	05/02/2023			
SHEET 7	STORM SEWER BEDDING DETAILS AND GENERAL NOTES	06/14/05	05/02/2023			
SHEET 8	SANITARY SEWER SPECIFICATIONS	06/14/05				
SHEET 9	SANITARY SEWER DETAILS	06/14/05				
SHEET 10	SANITARY SEWER LIFT STATION STANDARDS & GUIDELINES	06/14/05	05/02/2023			

### TOWN OF McCORDSVILLE



  
 THOMAS STRAYER TOWN COUNCIL PRESIDENT  
  
 GRANT ADAMS PUBLIC WORKS CHAIRMAN  
  
 TONYA GALBRAITH TOWN MANAGER  
  
 RONALD D. CRIDER PUBLIC WORKS COMMISSIONER

HOLEY MOLEY SAYS

"DIG SAFELY"



**"IT'S THE LAW"**  
 CALL 2 WORKING DAYS BEFORE YOU DIG  
**1-800-382-5544**  
 CALL TOLL FREE  
 PER INDIANA STATE LAW IC8-1-26,  
 IT IS AGAINST THE LAW TO EXCAVATE  
 WITHOUT NOTIFYING THE UNDERGROUND  
 LOCATION SERVICE TWO (2) WORKING DAYS  
 BEFORE COMMENCING WORK.

REVISIONS				RECOMMEND FOR APPROVAL  DESIGN ENGINEER	7/2/05 DATE	TOWN OF McCORDSVILLE	SHEET
REV. NO.	DESCRIPTION	DATE				1	OF
1	Various changes in red	4/18/2023				<b>DIRECTIONS FOR USE, GENERAL NOTES &amp; REVISION LOG</b>	

**LIME STABILIZATION**

**DESCRIPTION:** This work shall consist of upgrading of mostly fine grained soils by uniformly mixing small amounts of lime (~~3 to 6%~~ **4.5%**) by weight to provide a working platform for the road subbase.

**MATERIALS:** Material shall meet the requirements of the Section 913 of the INDOT Standard Specification  
**Cement (3% by weight) may be used as an alternative.**  
**LIME:**

- a) High calcium or dolomite Hydrated Lime (Ca(OH)<sub>2</sub> + Mg(OH)<sub>2</sub>) shall have a minimum of 90% total available calcium hydroxide content and the hydrates must contain no more than 5% carbon dioxide content if sampled at the lime plant, or no more than 7% if sampled at the job site.
- b) High calcium hydrated lime shall have a minimum available calcium hydroxide Ca(OH)<sub>2</sub> content of 90%. The method used for determination of available lime shall conform to AASHTO T219-72 or ASTM C25.
- c) Maximum Mechanical Moisture content shall be 4%.
- d) Gradation: All hydrated lime shall conform to the following gradation requirement. At least 85% passing a #200 sieve (0.075 mm). Determination of particle size shall conform to the provision for wet sieving on ASTM C110.
- e) ~~Quicklime or Kiln dust shall not be used.~~
- f) ~~Other lime products such as quicklime - high calcium (CaO) or Dolomite (CaO - MgO) may be substituted with written approval by the Town Engineer. By product lime (kiln dust) shall not be used.~~

**WATER:** Water used for lime modification shall be in accordance with all applicable requirements of 913 and 913.01 of the INDOT Specifications, except that the minimum acceptable pH is 6.5.

**STORAGE AND HANDLING**

- a) Hydrated lime shall be stored and handled in closed weatherproof containers until immediately before distribution on the subgrade. Hydrated lime in bags shall be stored in weather protected conditions with adequate protection from ground dampness, and the facility shall be approved by the Town Engineer prior to commencement of any lime work.
- b) Each shipment shall be accompanied by a bill of lading and by a certificate of compliance stating conformance to the applicable specification requirements. The certificate of compliance shall be submitted to the Town Engineer prior to the proof roll on the subgrade.
- c) The Contractor shall take appropriate preventive and protective (safety) measure that shall be exercised by those working with this material. All safety measures shall comply with applicable OSHA requirements.

**MIXTURE COMPOSITION:**

- a) **Mix Design:** Lime will be proportioned within a range of 3 to 6 percent of soil (oven - dry basis). The required proportion of lime will be recommended by the Contractor and approved by the Town Engineer prior to construction using samples of soil and lime. The Town Engineer reserves the right to make such adjustments of lime proportioning as are considered necessary during the progress of the work within the range specified.
- b) Source or type of lime shall not be changed during the progress of the work without permission of the Town Engineer. However, the Town Engineer may choose to use different types of lime on different portions of the project, but shall not be mixed.

**CONSTRUCTION REQUIREMENTS:**

- a) **Temperature and Weather Limitations:** No lime modification shall be performed at a soil temperature less than 45 degrees Fahrenheit (7 degrees C) and the air temperature rising, of subgrade soil when it is measured 4" (100 mm) below the surface. Lime shall not be mixed with frozen soils or with soil containing frost.
- b) **Preparation of Existing Roadway:** All deleterious material, such as stumps, roots, turf, etc. and aggregate larger than 3" (75 mm) shall be removed. Any soft organic soils shall be removed as directed by the Town Engineer.
- c) **Spreading of Lime:** The roadbed shall be scarified or disked prior to distribution of the lime. The machine shall be of such design that a visible indication is given at all times that the machine is cutting to the required depth; The lime shall than be distributed uniformly over the surface by means of cyclone, screw-type, or pressure manifold type distributor. The Town Engineer may reject any procedure which does not provide even distribution of lime.

Lime shall not be applied when wind conditions are such that blowing lime becomes objectionable to adjacent property owners or creates a hazard to traffic on adjacent roadways.

The spreading of lime shall be limited to the amount which can be incorporated after mixing. In no case shall compaction be started later than three (3) days after mixing into the soil. In the event that rain intervenes causing cessation of work and exposure of the lime to washing or blowing, the Town Engineer may require additional lime to be spread.

d) **Mixing:** The lime, soil and water (if necessary) shall be thoroughly blended by rotary speed mixers or a disc harrow. The mixing shall continue until a homogeneous layer of the required thickness has been obtained and clods are broken down so that 100%, exclusive of rock particle, will pass a one-inch (25 mm) sieve and at least 60% will pass a 4 sieve (4.75 mm). The loose thickness of a single lime modified layer shall not exceed eight (8) inches (200 mm) if a disc harrow is used and fourteen (14) inches (355 mm) if a rotary speed mixer is used.

e) **Compaction:** Compaction of the mixture shall begin as soon as is practicable mixing unless approved by the Town Engineer. If compaction is to be delayed, the surface of the lime modified soil shall be crown-graded and sealed by either blade dragging or light rolling immediately after mixing.

Compaction shall be continued until the Contractor has shown that the lime modified layer has a density not less than 100 percent within the special subgrade treatment zone and/or 95 percent below special subgrade treatment zone, of the maximum dry density.

The standard dry density of the lime treated soil shall be obtained by AASHTO 99. The field in-place dry density will be obtained by the Contractor in accordance with AASHTO T 191.

Aeration by means of further mixing, or the addition of water and further mixing, may be required by the Town Engineer to achieve the required compaction.

f) **Finishing:** When compaction of the lime modified soil is nearing completion, the surface shall be shaped to the required line, grades and cross section, and compaction continued until uniform and adequate compaction is obtained.

The Town Engineer reserves the right to determine the actual thickness of the completed and cured layer by coring or other means at the owner's expense, and any deficient areas shall be acceptably corrected.

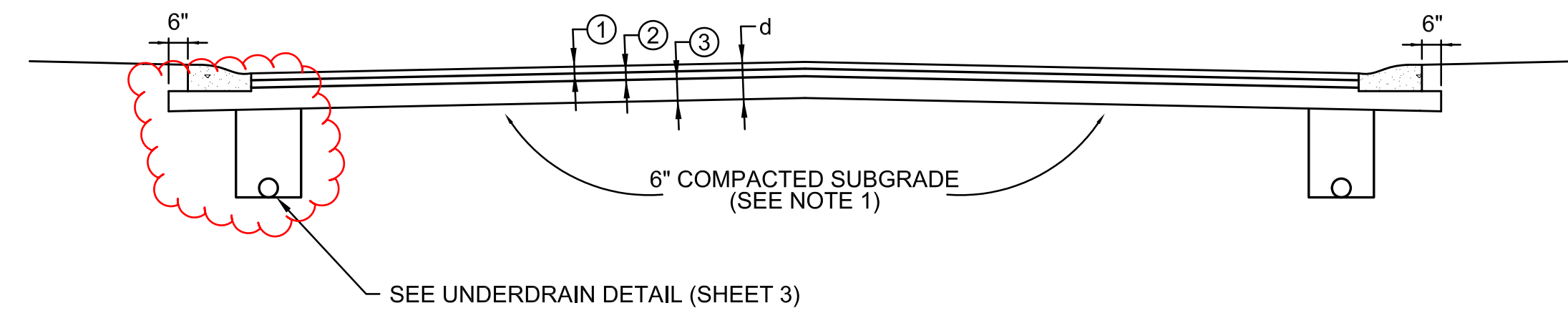

**NOTES:**

- 1. HMA SHALL BE PRODUCED FROM AN INDOT CERTIFIED HMA PLANT, IN ACCORDANCE WITH INDIANA TEST METHOD (ITM) 583.
- 2. THE CONTRACTOR SHALL PROVIDE A COPY OF THE CERTIFICATION TO THE TOWN ENGINEER AT OR BEFORE THE INSTALLATION OF THE HMA.
- 3. PG BINDER MATERIAL (LIQUID) SHALL BE PG-64-22 FOR TYPE A AND TYPE B MIXES.
- 4. RECYCLED MATERIALS, UP TO 25%, MAY BE USED BASE. ~~IF OVER 15% RECYCLED MATERIAL IS USED, PG BINDER 58-28 SHALL BE USED RATHER THAN PG-64-22.~~

- LOCAL ROAD**
- d = 12"
- ① 1.5" HMA, TYPE A, 9.5 MM SURFACE
  - ② 2.5" HMA, TYPE A, 19.0 MM INTERMEDIATE
  - ③ 4" COMPACTED AGGREGATE BASE #53  
4" COMPACTED AGGREGATE BASE #2

- LOCAL COLLECTOR ARTERIAL ROAD**
- d = 15"
- ① 1.5" HMA, TYPE A, 9.5 MM SURFACE
  - ② 2.5" HMA, TYPE A, 19.0 MM INTERMEDIATE
  - ③ 3" HMA, TYPE A, 25.0 MM BASE
  - ④ 4" COMPACTED AGGREGATE BASE #53  
4" COMPACTED AGGREGATE BASE #2

**Arterial Road (CR 600 West / Mt Comfort Road)**  
 ENTRANCE ASPHALT SECTION (WITHIN CURB - NGSDW R.O.W.) IS AS FOLLOWS:

- COLLECTOR ROAD**
- d = 18"
- ① 1.5" HMA, TYPE B, 9.5 MM SURFACE
  - ② 2.5" HMA, TYPE B, 19.0 MM INTERMEDIATE
  - ③ 6" HMA, TYPE B, 25.0 MM BASE
  - ④ 4" COMPACTED AGGREGATE BASE #53  
4" COMPACTED AGGREGATE BASE #2

- 1.5" HMA SURFACE 9.5mm
- 2.5" HMA INTERMEDIATE 12.5mm
- 4" HMA BASE 19.0mm
- 6" HMA BASE 19.0mm
- 4" COMPACTED AGGREGATE #53
- 4" COMPACTED AGGREGATE #2
- LIME STABILIZED SUBGRADE (SEE McCORDSVILLE SPECIFICATIONS)

**PAVEMENT CONSTRUCTION**

SCALE: NONE

**PAVEMENT CONSTRUCTION**

- 1.) Subgrade shall be lime stabilized per the lime stabilization specification on this sheet.
- 2.) Adequacy of existing subgrades shall be determined solely by the town based on a contractor performed proof roll with a fully loaded tri-axle dump truck. A proof roll shall be performed on all street subgrade prior to placing stone, under drains and installing curb. A second proof roll shall be performed on the stone prior to placing the asphalt base. The adequacy of the stone and subgrade shall be determined solely by the town.
- 3.) Place tack coat in accordance with the most recent INDOT standard specifications for asphalt pavement sections.
- 4.) Local ~~Arterial~~ **Collector** Road is defined as a low capacity and low speed roads within subdivisions whose function is to become a collector street for local subdivision traffic and move traffic from within the community to other locations in the community and to the existing county roads. Whether a street is defined as a Local Arterial Road is at the sole discretion of the Public Works Commissioner.
- 5.) Installation of or provisions for installation of all underground utilities (including service lines and laterals) shall be placed prior to the construction of pavement including lime stabilization.
- 6.) Paving of base and/or intermediate shall occur when temperatures are 32 degrees and rising. Surface paving of 1.5" or greater shall be when temperatures are 40 degrees and rising. Surface paving of 1" or less shall be when temperatures are 45 degrees and rising.

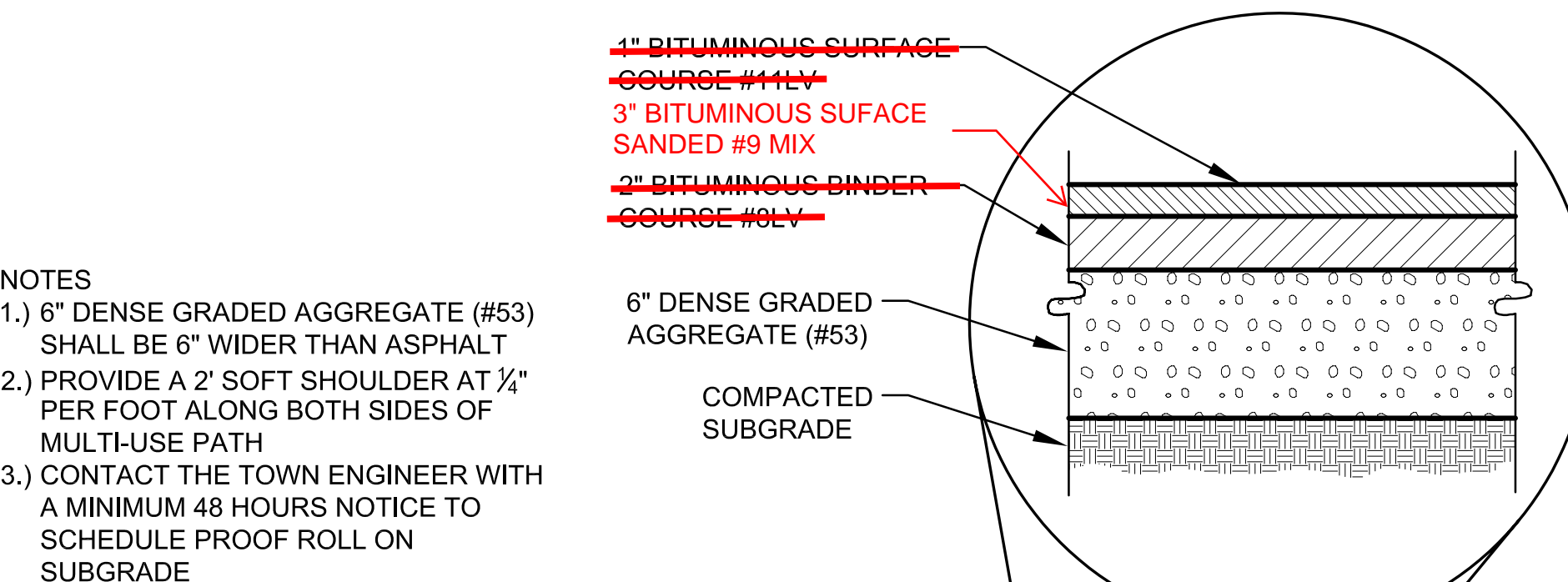

**NOTES**

- 1.) 6" DENSE GRADED AGGREGATE (#53) SHALL BE 6" WIDER THAN ASPHALT
- 2.) PROVIDE A 2" SOFT SHOULDER AT 1/4" PER FOOT ALONG BOTH SIDES OF MULTI-USE PATH
- 3.) CONTACT THE TOWN ENGINEER WITH A MINIMUM 48 HOURS NOTICE TO SCHEDULE PROOF ROLL ON SUBGRADE

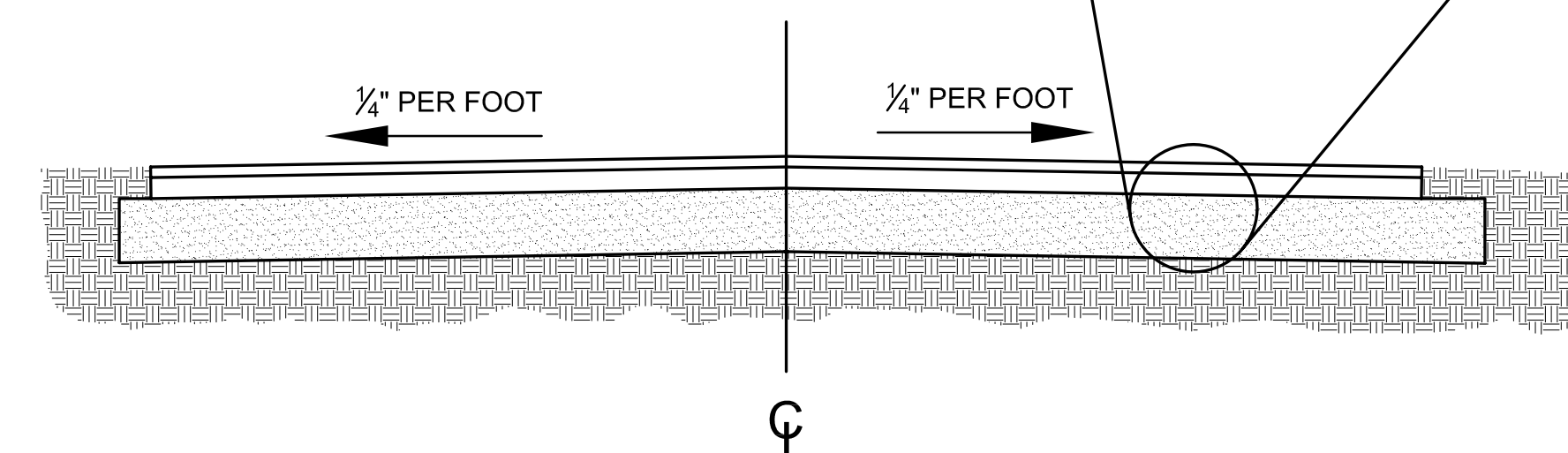

**MULTI-USE PATH DETAIL**

SCALE: NONE

REVISIONS		
REV. NO.	DESCRIPTION	DATE
1	Various changes in red	4/18/2023

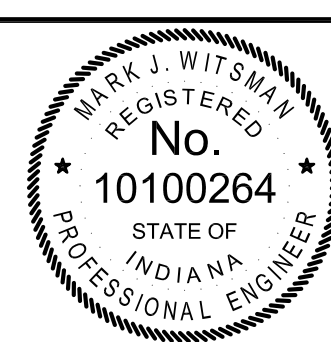

RECOMMEND FOR APPROVAL	<i>[Signature]</i>	7/12/05
DESIGN ENGINEER		DATE
APPROVED	<i>[Signature]</i>	7/12/05
PUBLIC WORKS COMMISSIONER		DATE
APPROVED	<i>[Signature]</i>	7/12/05
TOWN COUNCIL PRESIDENT		DATE

<b>TOWN OF McCORDSVILLE</b>	<b>TOWN STANDARDS RIGHT-OF-WAY SECTIONS &amp; PAVEMENT SPECIFICATIONS</b>	<b>SHEET</b>
		<b>2 OF 10</b>



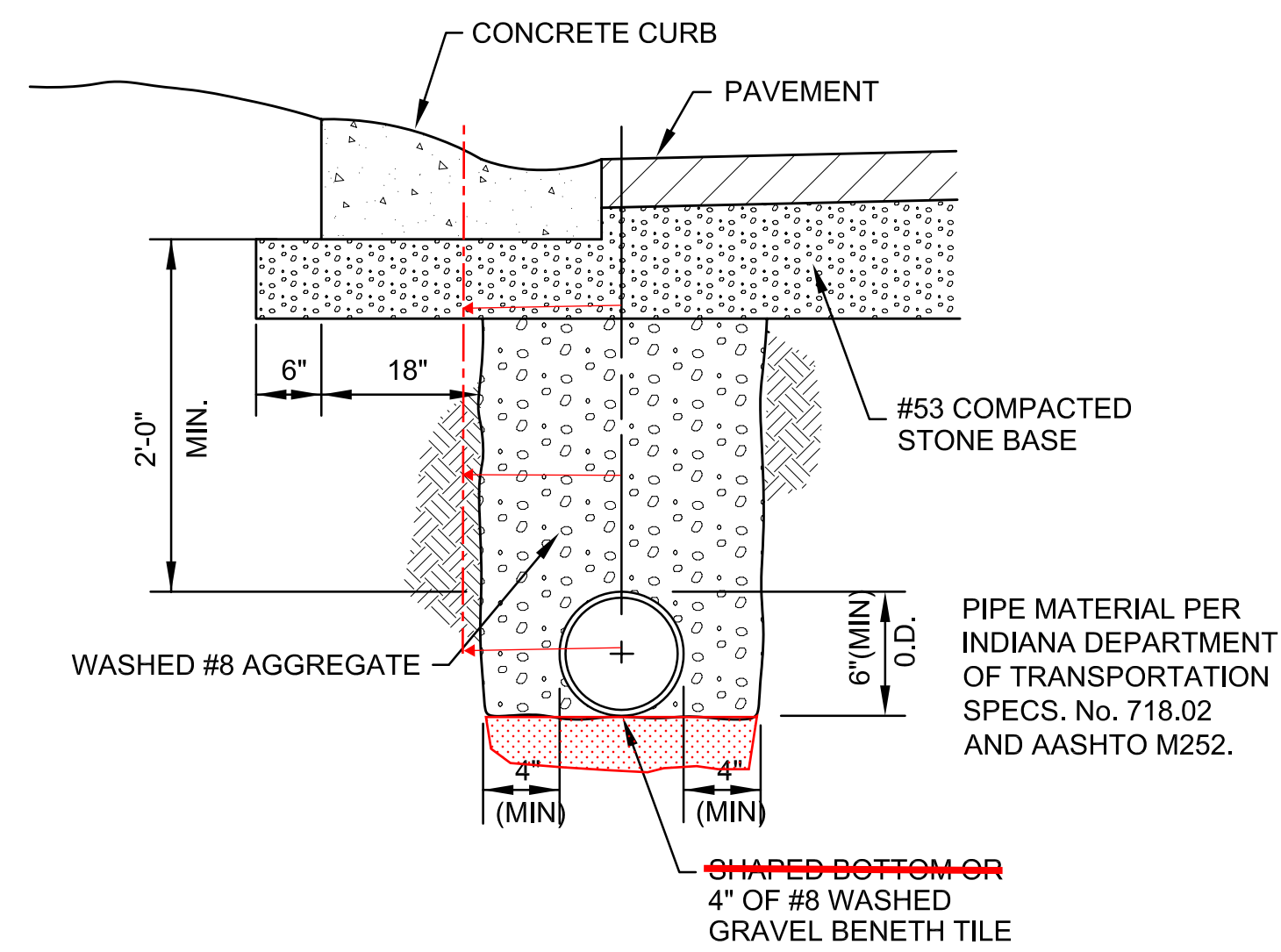

**UNDERDRAIN DETAIL**  
SCALE: NONE

**STREET SIGN STANDARDS**

All traffic and road name signs in and as a result of a major subdivision or a minor subdivision with newly constructed streets, shall be supplied and installed by the developer. The placement of the signs shall be as shown on the traffic sign plan that is to be submitted with the construction drawings. The traffic sign plan shall show the type of sign, size of sign, location of sign with dimensions and the streets to scale. **A five (5) year maintenance bond shall be posted on the signs.** The installer or developer shall notify the Town Engineer in writing when the signs are installed, so they can be inspected. Also include the date and time of installation of each sign. The plat shall not be recorded until the signs have been accepted.

**TRAFFIC SIGNS**

- 1.) Traffic signs shall be designed and installed to conform with the applicable requirements of the Indiana Manual of Uniform Traffic Control Devices, latest edition.
- 2.) No spliced sheeting unless acceptable by the Indiana Department of Transportation standard specifications, latest edition.
- 3.) Reflective sheeting for traffic signs shall be encapsulated lens (high intensity).
- 4.) Posts used for traffic signs shall be **3/8" galvanized channel posts, 2 3/8" galvanized round posts with a 8" equilateral triangle**
- 5.) Traffic sign height shall comply with the Indiana Manual of Uniform Traffic Control Devices, latest edition. **welded to 24" from the bottom of the post.**
- 6.) Posts shall be installed with no less than three (3) feet of post in the ground.
- 6.) Backing material will be made of sheet aluminum.
- 7.) Bolts for mounting shall be 5/16" galvanized, stainless steel **or plated carriage bolts.**
- 8.) The number of posts for mounting and the minimum thickness or gage of sheet shall be as shown for the appropriate sign width:

WIDTH(inches)	NO. OF POSTS	THICKNESS (inches) ALUMINUM SHEET
Up to 24"	1	0.080
25" to 30"	1	0.080
31" to 60"	2	0.100
61" and over	2	0.125

**STREET NAME SIGNS**

- 1.) Intersections shall have one (1) road name sign for each street. **(Diamond grade reflectivity) with white border.**
- 2.) All road name signs shall be made of an aluminum extruded blade. **black**
- 4.) Reflective sheeting for road name signs shall be inclosed lens (high intensity), **green in color.**
- 5.) Letters and numerals for the road name signs shall be high intensity reflective **sheeting, series B** letters, and white in color.
- 3.) Posts used for road name signs shall be **2 1/2" galvanized channel posts, 2 3/8" galvanized round posts.**
- 6.) Minimum height to bottom of sign for road name signs shall be seven (7) feet.
- 7.) Posts shall be installed with no less than three (3) feet of post in the ground.
- 8.) Material for posts shall be galvanized steel.
- 7.) Bolts for mounting shall be 5/16" galvanized, stainless steel or plated carriage bolts.

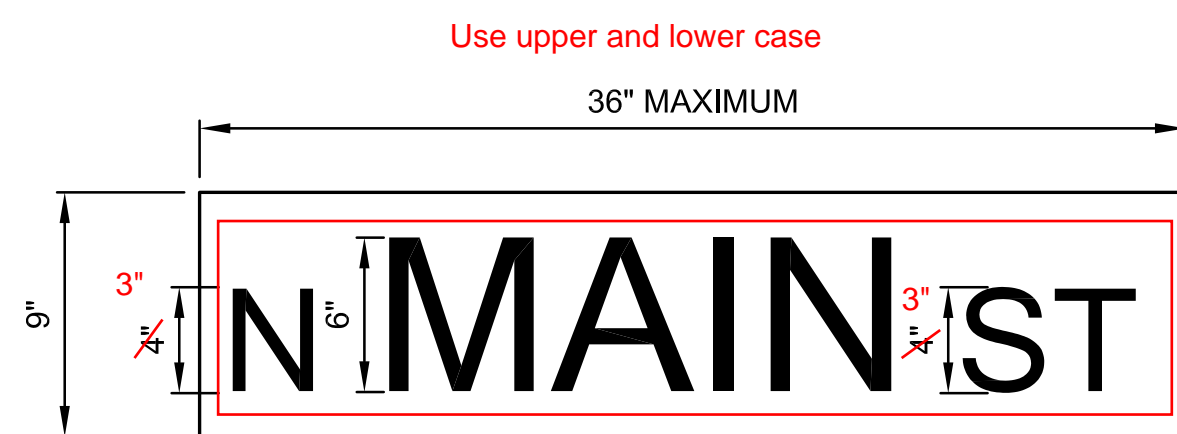

**ROAD NAME SIGN DETAIL**  
SCALE: NONE

1. THE EXISTING PAVEMENT IS TO BE SAW CUT TO PROVIDE A CLEAN JOINT.
2. TRENCH SPOIL IS TO BE REMOVED FROM THE WORK SITE AND DISPOSED OF OUT OF THE RIGHT-OF-WAY AT A PREDESIGNATED APPROVED AREA.
3. FLOWABLE FILL IS TO BE POURED INTO THE TRENCH TO SERVE AS BACKFILL, TO THE DIMENSIONS AND SPECIFICATIONS LISTED IN THIS DETAIL.
4. THE ASPHALT PATCH IS TO CONSIST OF A MINIMUM OF 5 (FIVE) INCHES OF #8 HAC BITUMINOUS BINDER AND 1 (ONE) INCH OF #11 HAC BITUMINOUS SURFACE. IF THE EXISTING PAVEMENT IS THICKER THAN 6 (SIX) INCHES, ADDITIONAL BINDER IS TO BE USED TO MATCH THE EXISTING PAVEMENT THICKNESS. IN NO CASE IS LESS THAT 6 (SIX) INCHES OF ASPHALT TO BE USED.
5. THE EXISTING PAVEMENT IS TO BE TACK COATED PRIOR TO THE LAYING OF NEW ASPHALT. TACK COAT IS TO BE APPLIED AS SPECIFIED IN THE LATEST INDOT SPECIFICATIONS, SECTIONS 409 AND 902.
6. THE NEW SURFACE IS TO BE SLOPED AT THE SAME RATE AS THE EXISTING SURFACE.
7. A 2 (TWO) INCH WIDE BAND OF CRACK SEALANT IS TO BE APPLIED ALONG THE JOINT BETWEEN THE EXISTING AND NEW ASPHALT SURFACE. SEALANT IS TO BE APPLIED IN ACCORDANCE WITH INDOT SPECIFICATIONS, SECTION 305.
8. THE FLOWABLE FILL MIX IS TO CONTAIN, FOR EVERY CUBIC YARD OF BATCH MATERIAL, NO MORE THAN 50 LBS OF PORTLAND CEMENT, NO MORE THAN 500 LBS OF WATER.
9. THE COMPRESSIVE STRENGTH OF THE FLOWABLE FILL IS NOT TO EXCEED 100 PSI AT 28 DAYS.

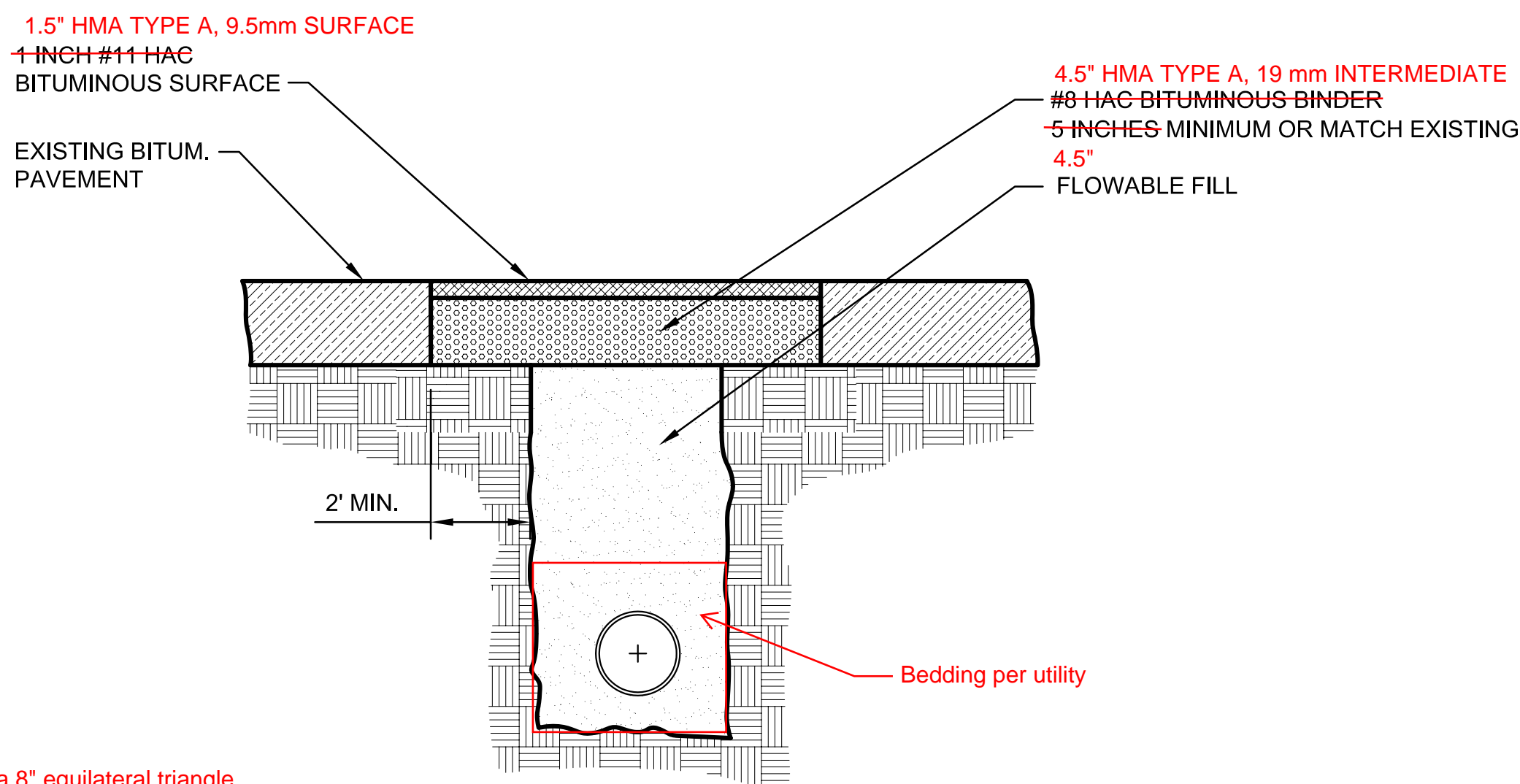

**ROAD CUT PATCH DETAIL**  
NOT TO SCALE

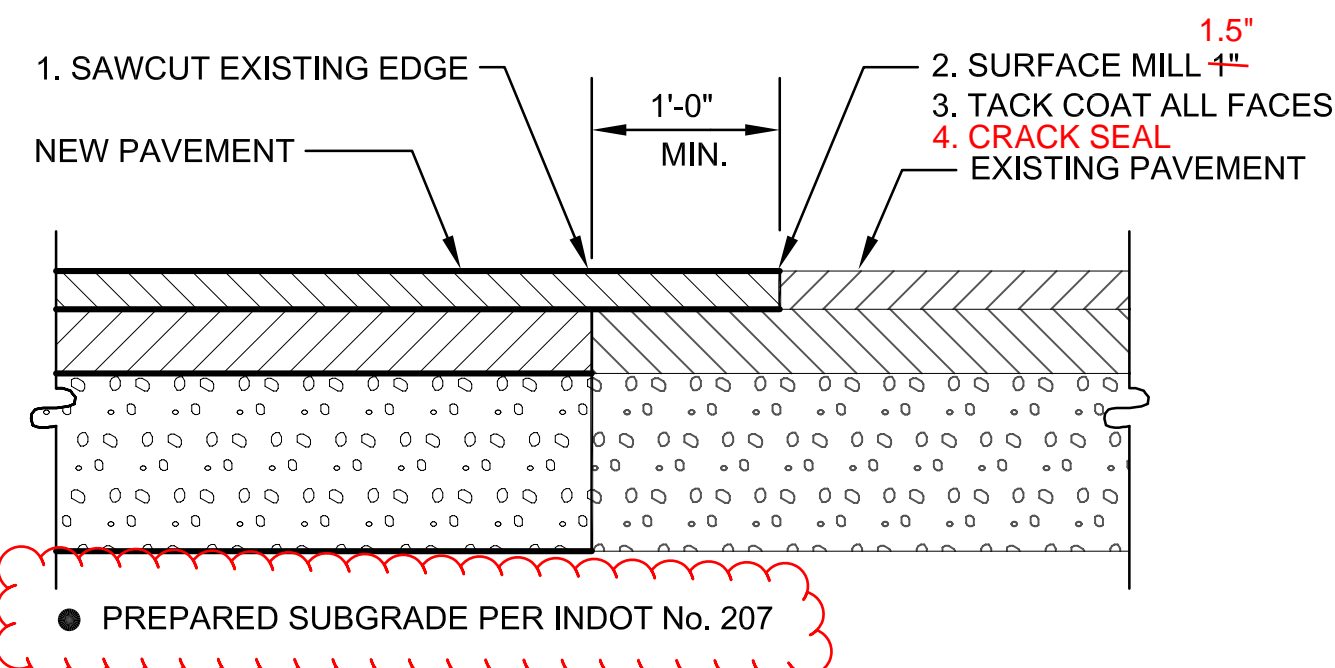

**TYPICAL PAVEMENT TIE-IN**  
SCALE: NONE

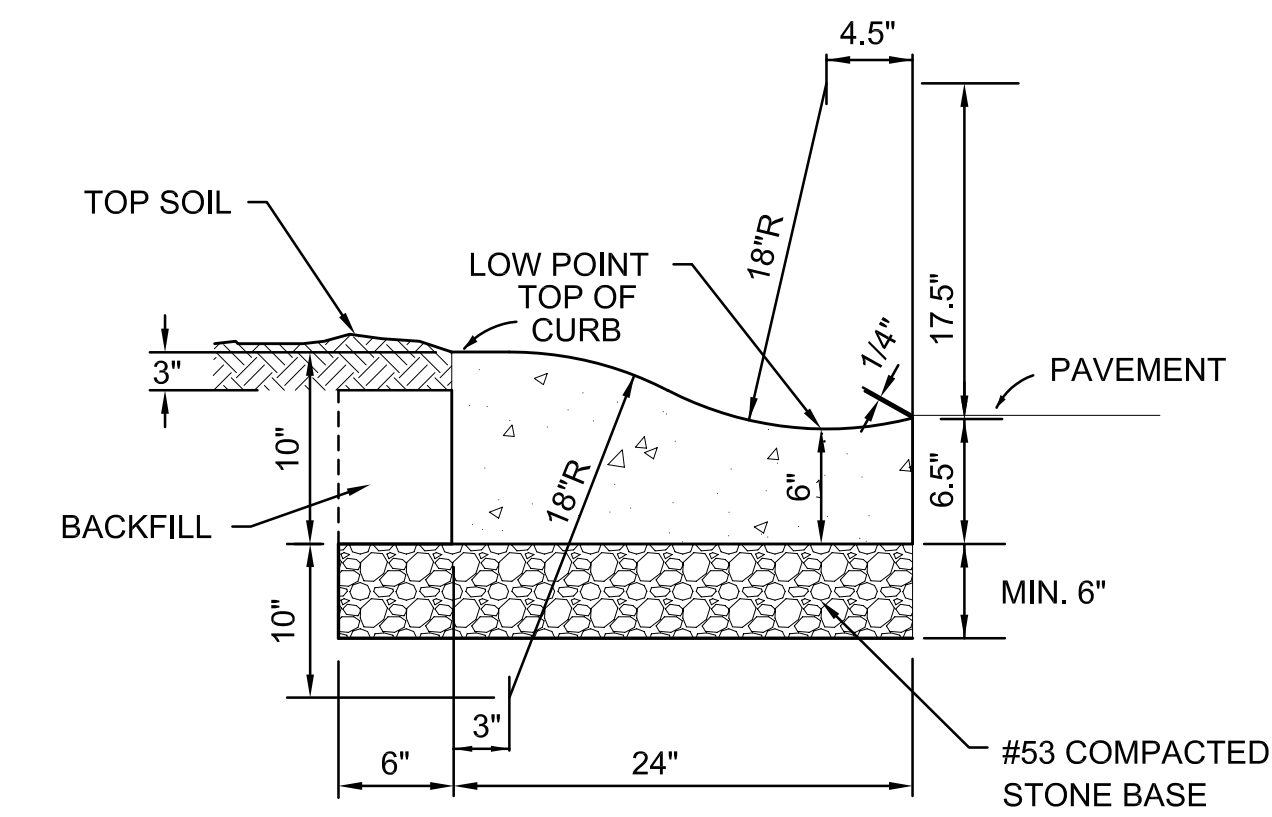

(TYPE I)  
**2' CONCRETE ROLL CURB & GUTTER**  
SCALE: NONE

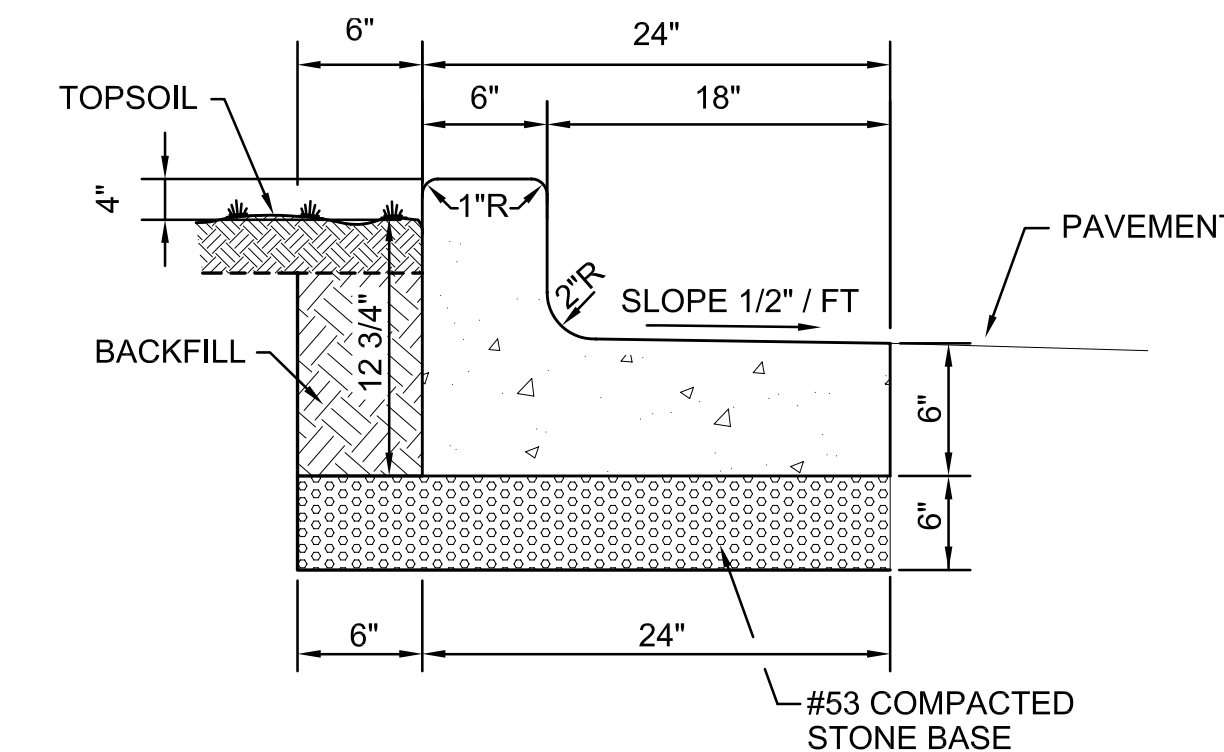

(TYPE II)  
**2' COMBINED CONCRETE CURB AND GUTTER**  
SCALE: NONE

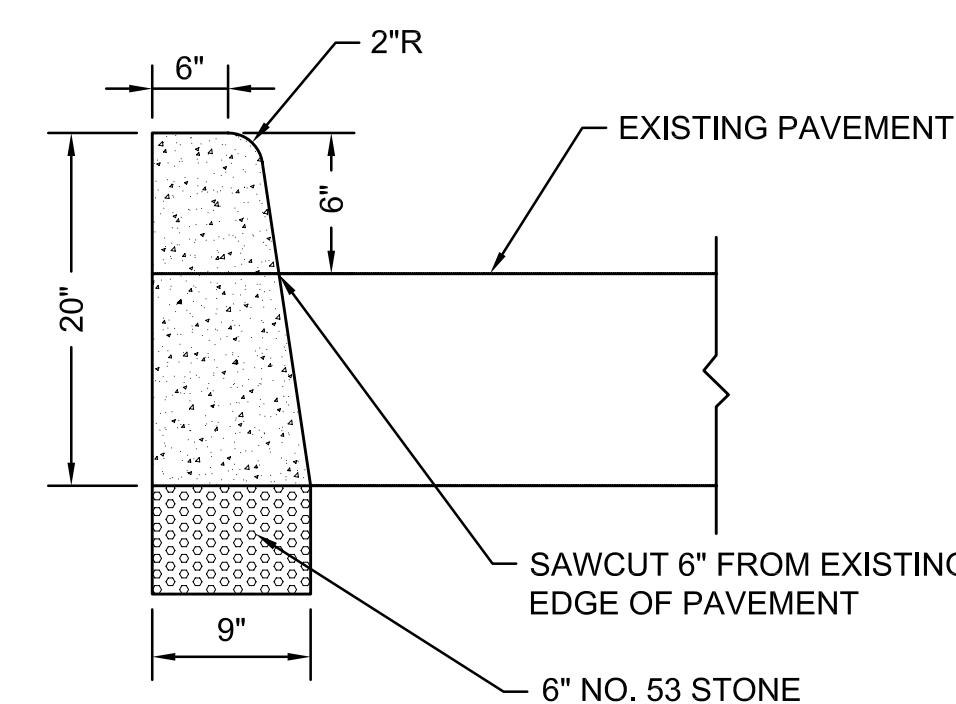

**CONCRETE CURB (BARRIER)**  
SCALE: NONE

REVISIONS		
REV. NO.	DESCRIPTION	DATE
1	Various changes in red	4/18/2023



RECOMMEND FOR APPROVAL	<i>Mark J. Witsman</i>	7/12/05
DESIGN ENGINEER		DATE
APPROVED	<i>Ronald D. Cooney</i>	7/12/05
PUBLIC WORKS COMMISSIONER		DATE
APPROVED	<i>Mark J. Witsman</i>	7/12/05
TOWN COUNCIL PRESIDENT		DATE

**TOWN OF McCORDSVILLE**  
**TOWN STANDARDS**  
**RIGHT-OF-WAY DETAILS**

**SHEET**  
**3**  
**OF**  
**10**

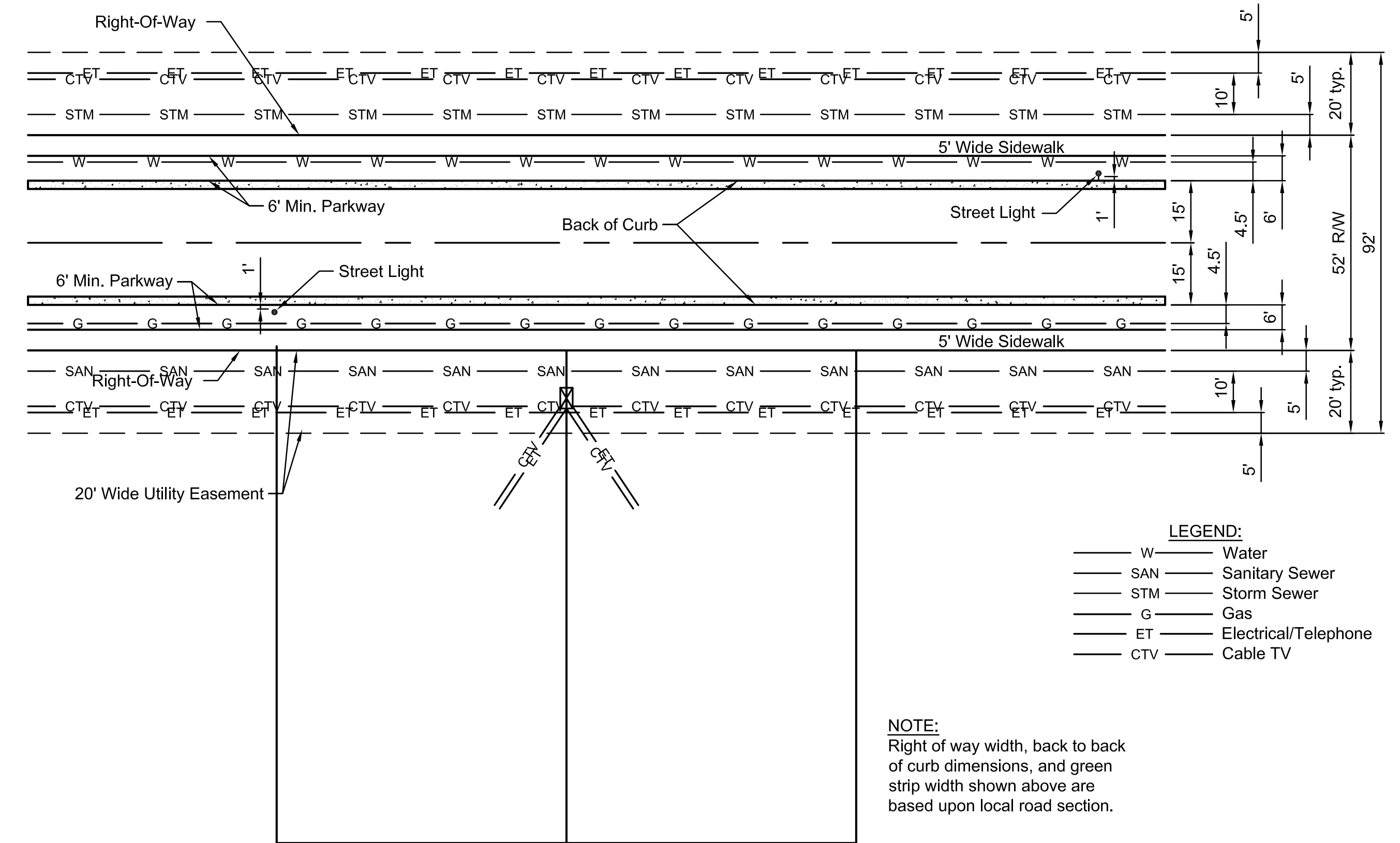

- LEGEND:**
- W — Water
  - SAN — Sanitary Sewer
  - STM — Storm Sewer
  - G — Gas
  - ET — Electrical/Telephone
  - CTV — Cable TV

**NOTE:**  
Right of way width, back to back of curb dimensions, and green strip width shown above are based upon local road section.

**TYPICAL LOT UTILITY LOCATION**  
NOT TO SCALE

**GENERAL NOTES:**  
1.) The location of proposed utilities as indicated hereon are based upon the orderly development of the land. Strict adherence to the indicated location is required. Requests to change the location of the proposed utilities shall be submitted in writing to the Public Works Commissioner. Utilities not meeting these requirements shall be removed and replaced as directed by the Public Works Commissioner at the owner's expense.

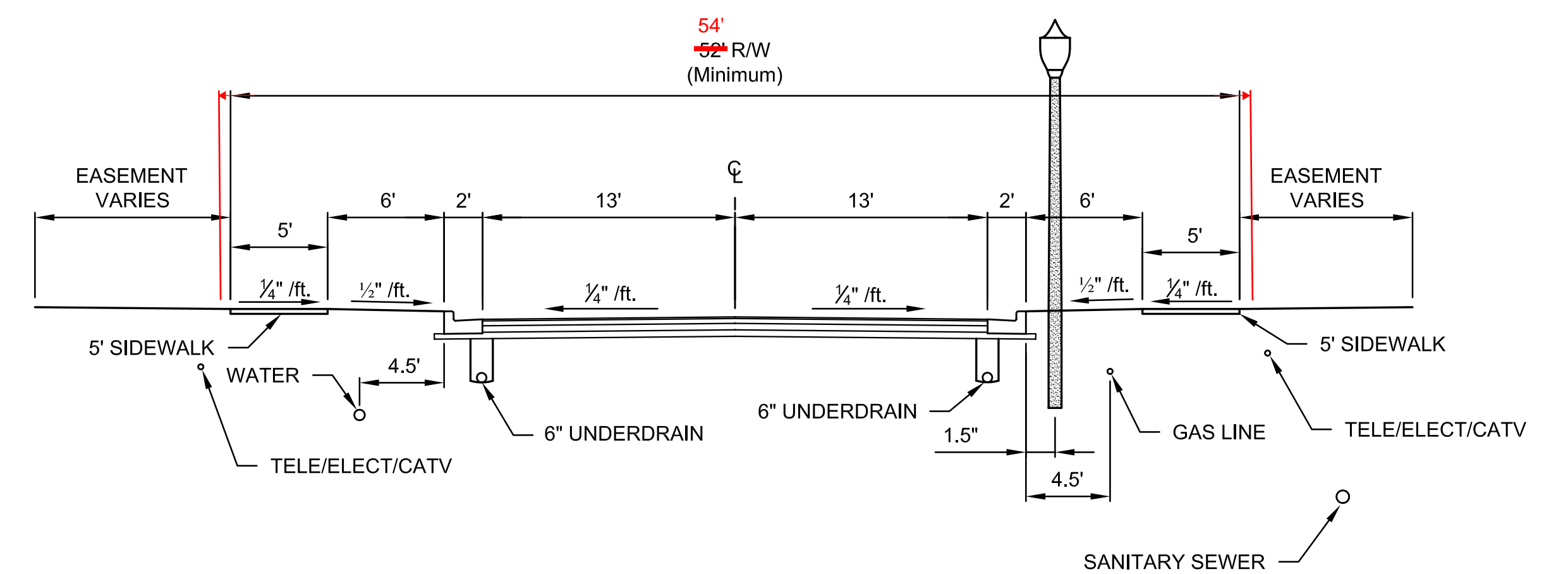

**TYPICAL LOCAL ROAD UTILITY LOCATION**  
NOT TO SCALE

REVISIONS		
REV. NO.	DESCRIPTION	DATE
1	Various changes in red	4/18/2023



RECOMMEND FOR APPROVAL: *Mark J. Witsman* 7/12/05 DATE  
DESIGN ENGINEER

APPROVED: *Ronald D. Coyle* 7/12/05 DATE  
PUBLIC WORKS COMMISSIONER

APPROVED: *Mark J. Witsman* 7/12/05 DATE  
TOWN COUNCIL PRESIDENT

**TOWN OF McCORDSVILLE**

**TOWN STANDARDS  
UTILITY LOCATION  
GUIDELINES**

**SHEET  
4  
OF  
10**

## RESIDENTIAL DRIVES

- 1.) THE MAXIMUM ALGEBRAIC DIFFERENCE IN GRADE FOR ANY 10 FOOT INTERVAL SHALL NOT EXCEED 8% FOR CREST VERTICAL CURVES. NOR 10% FOR SAG VERTICAL CURVES.
- 2.) ALL LOTS SHALL DRAIN TO ADJACENT STREETS EXCEPT WITH THE PRIOR APPROVAL OF THE PUBLIC WORKS COMMISSIONER.
- 3.) CONCRETE DRIVES REQUIRE CONTROL JOINTS EVERY 10 FEET EACH WAY.

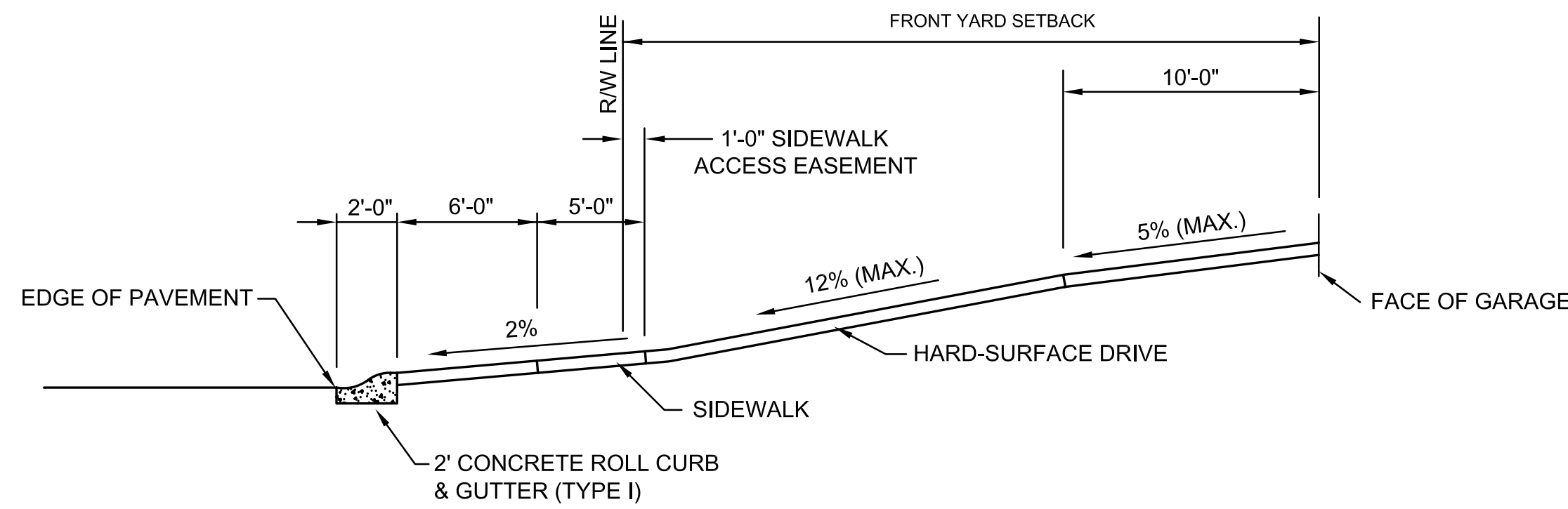

SECTION "A-A"

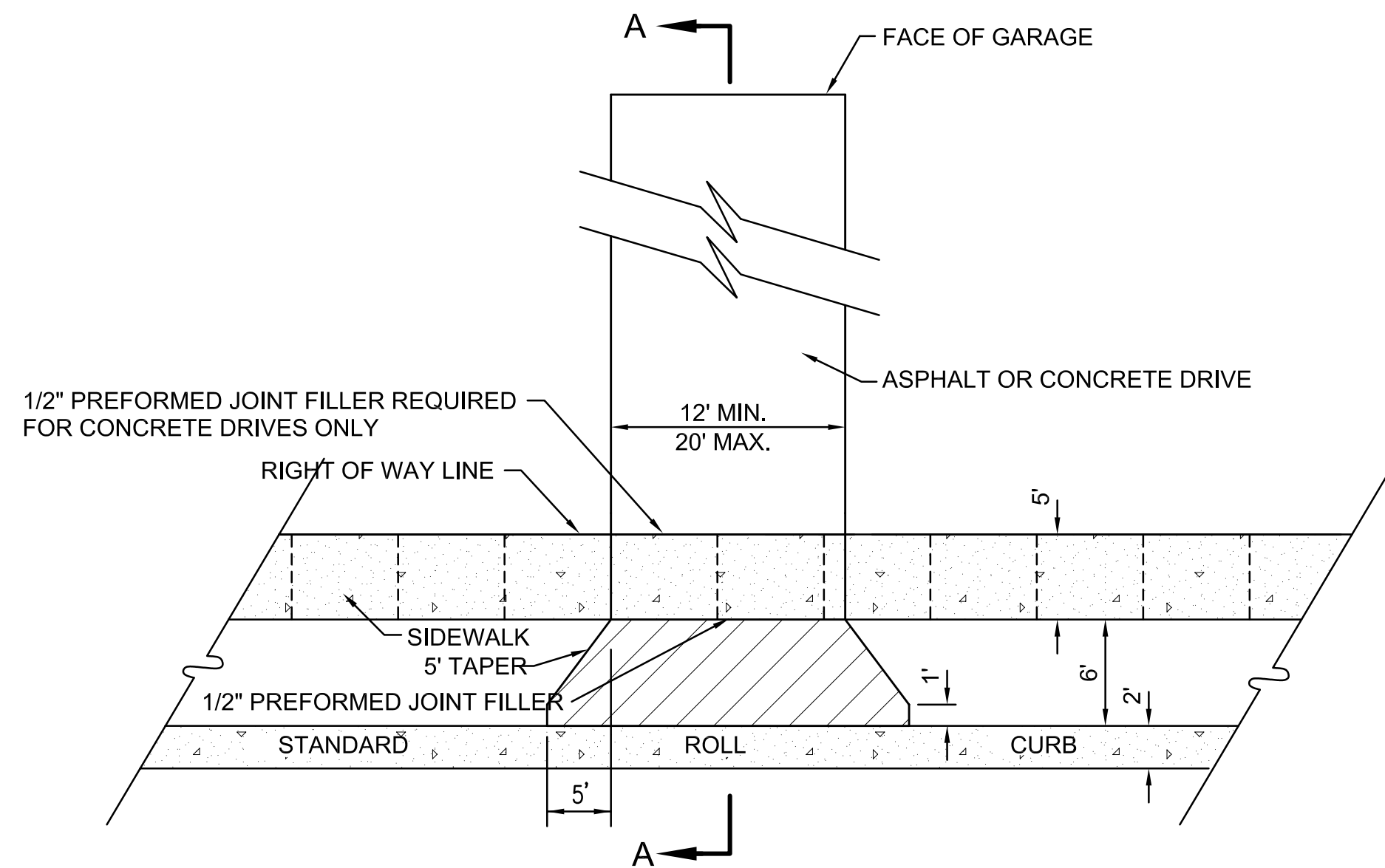

1. CROSS HATCHED AREAS SHALL BE EITHER 6" PLAIN CONCRETE OR 1" SURFACE ON 2" BITUMINOUS BASE ON 4" #53 COMPACTED AGGREGATE BASE, EXTENDING TO THE SIDEWALK OR R/W LINE WHICHEVER IS NEAREST TO THE ROADWAY.
2. SUBGRADE UNDER ALL SIDEWALKS AND DRIVES SHALL BE IN ACCORDANCE WITH SECTION 207.02 OF CURRENT INDOT STANDARD SPECIFICATIONS.
3. SIDEWALKS SHALL BE CONSTRUCTED IN ACCORDANCE WITH THE APPROPRIATE STANDARD AND SHALL BE CONTINUOUS ACROSS THE DRIVEWAY. SIDEWALK SECTION ACROSS DRIVEWAY SHALL BE SAME THICKNESS AS DRIVEWAY WITH A 6-INCH MINIMUM.
4. Driveways are not to be located where a curb inlet is located.

## RESIDENTIAL DRIVEWAY DETAIL

SCALE: NONE

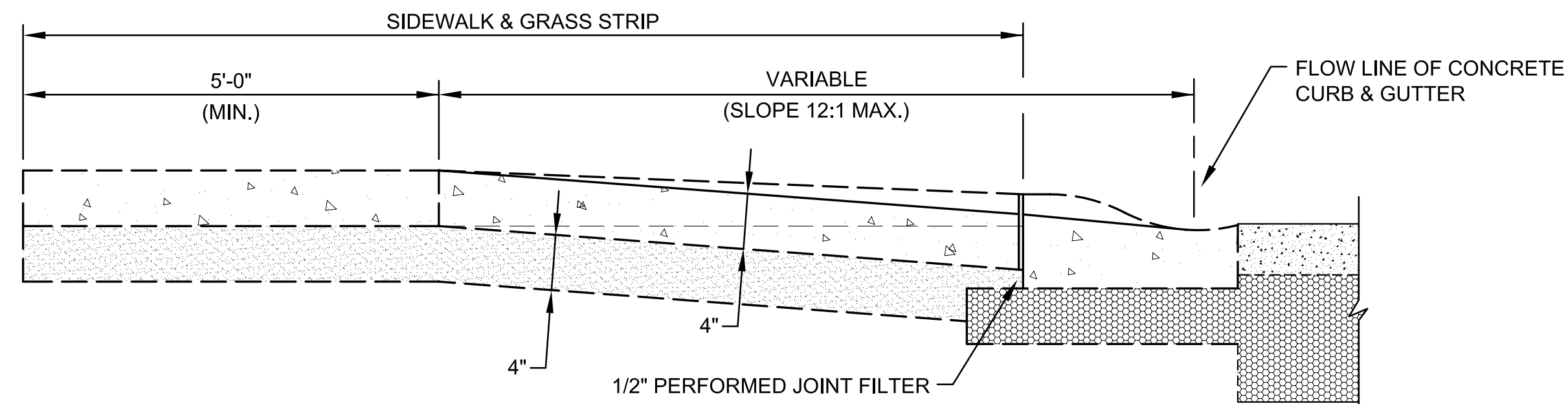

SECTION "A-A"

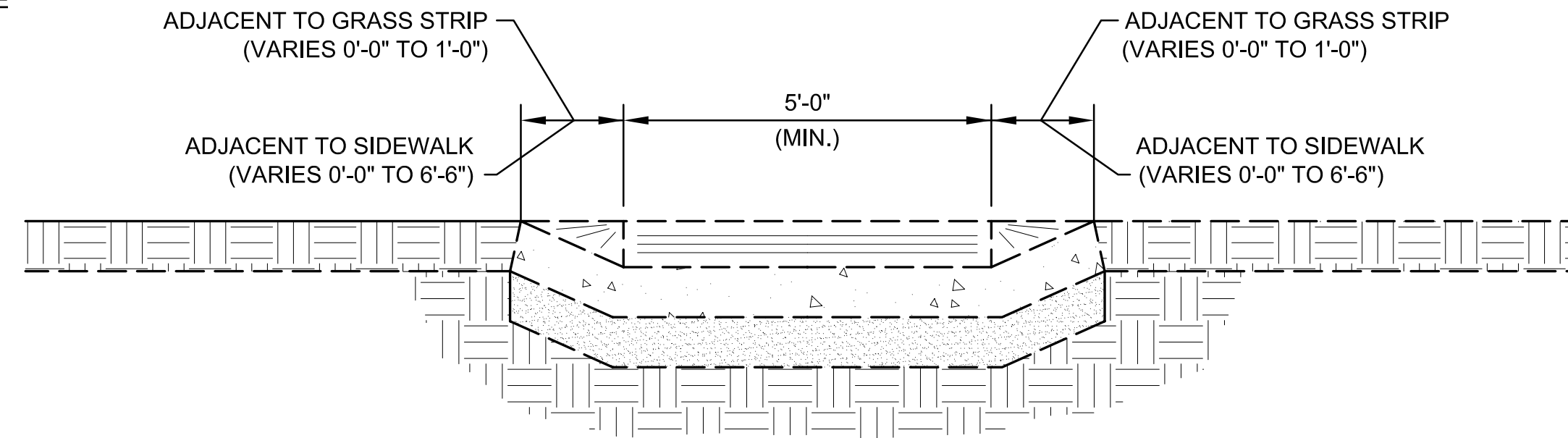

SECTION "C-C"

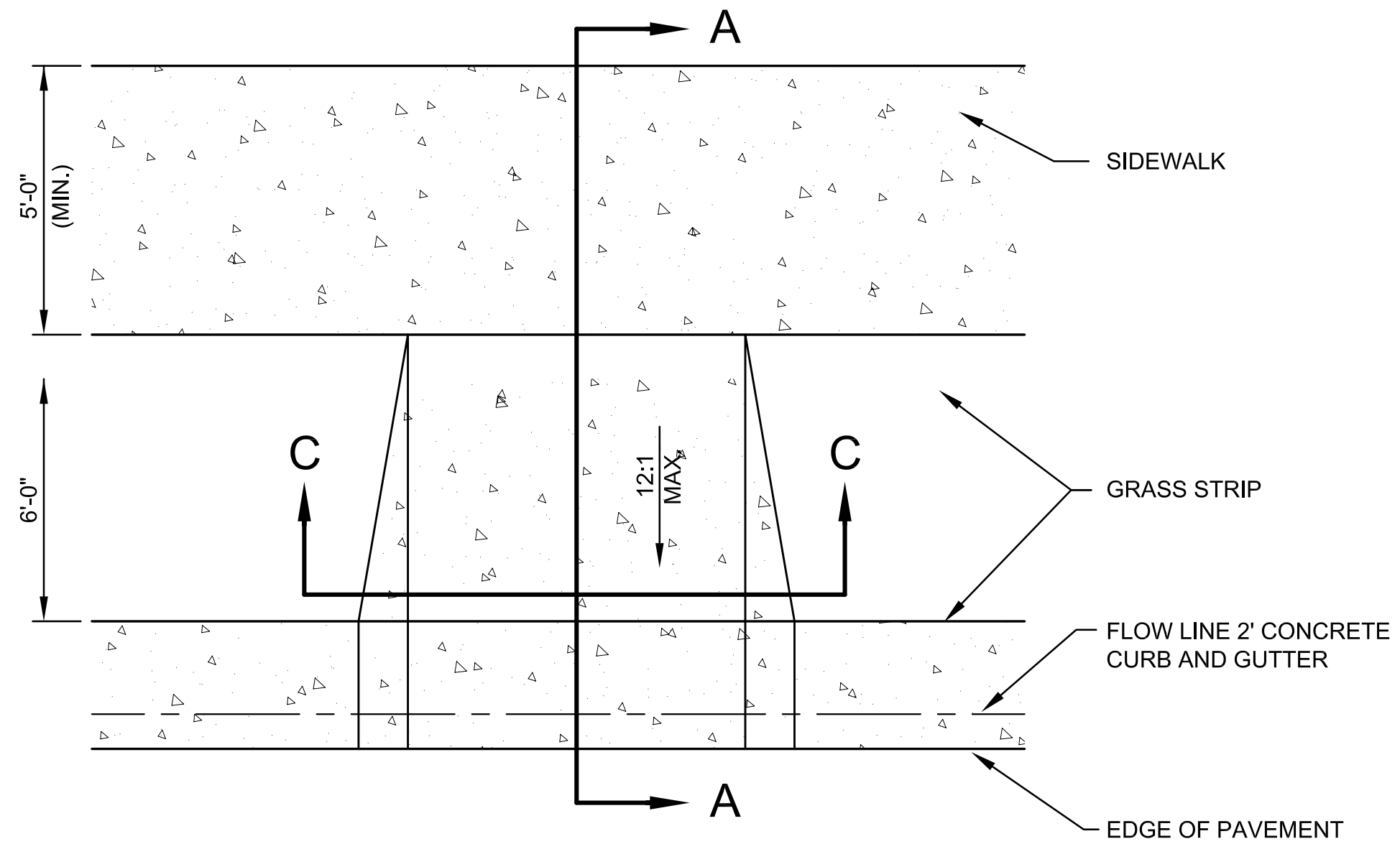

## HANDICAP RAMP CONSTRUCTION

SCALE: NONE

## HANDICAP RAMP CONSTRUCTION

1.) All handicap ramps shall meet the requirements of the American Disabilities Act, the most recent INDOT standard specifications, and the Town of McCordsville's most recent standards. Curb modifications required for handicap ramps shall be provided at time of initial construction.

2.) Minimum width of curb ramp shall be 5 feet not including flares. Maximum slope of ramps and flares shall be 12:1.

3.) Handicap ramps are to be located as shown on the plans or as directed by the Public Works Commissioner. Modify for 8 ramps per intersection.

4.) Ramps shall be provided at the centerline of radius at all corners of every street intersection where there is an existing or proposed sidewalk and curb. Ramps shall also be provided at walk locations at mid-block in vicinity of hospitals, medical centers, or athletic stadiums. The use of details contrary to those shown hereon shall require the prior written approval of the Public Works Commissioner.

5.) Surface texture of the ramp shall be ramp grooves located 2" on center and 0.3" deep.

6.) Care shall be taken to assure a uniform grade on all ramps with no breaks in grade.

7.) Drainage structures shall not be placed in line with the ramps except where existing drainage structures are being utilized in the new construction. Location of the ramps shall take precedence over location of drainage structures.

8.) The normal gutter line profile shall not be maintained through the area of the ramp. Drainage inlets should be located uphill from the curb ramps to prevent puddles at the path of travel.

9.) Expansion joint for the ramp shall be a maximum 1/2" wide. The top of the joint filler for all ramp types shall be flush with adjacent concrete.

10.) Crosswalk and stop line marking, if used, shall be so located as to stop traffic short of ramp crossing.

11.) ADA ramp is to be located outside of driveways.

## 10' MULTI-USE CONCRETE PATH CONSTRUCTION SIDEWALK CONSTRUCTION

fiber reinforced

1.) Sidewalks shall be constructed of plain concrete four (4) inches thick except where crossing driveways where the sidewalk shall be a minimum of six (6) inches thick.

2.) Sidewalks shall be constructed on 2" of crushed stone or sand.

3.) Control joints shall be placed every 5 feet on center.

4.) Expansion joints shall be placed every 40 feet on center.

5.) Broom finish across the direction of travel and include a 1" steel trowel finish along both sides of the sidewalk and along either side of all expansion and control joints.

REVISIONS		
REV. NO.	DESCRIPTION	DATE
1	Various changes in red	4/18/2023



RECOMMEND FOR APPROVAL	<i>Mark J. Witsman</i>	DESIGN ENGINEER	7/12/05	DATE
APPROVED	<i>Ronald D. Coe</i>	PUBLIC WORKS COMMISSIONER	7/12/05	DATE
APPROVED	<i>Mark J. Witsman</i>	TOWN COUNCIL PRESIDENT	7/12/05	DATE

**TOWN OF McCORDSVILLE**

**TOWN STANDARDS DRIVE WAY AND HANDICAP RAMP DETAILS**

**SHEET 5 OF 10**

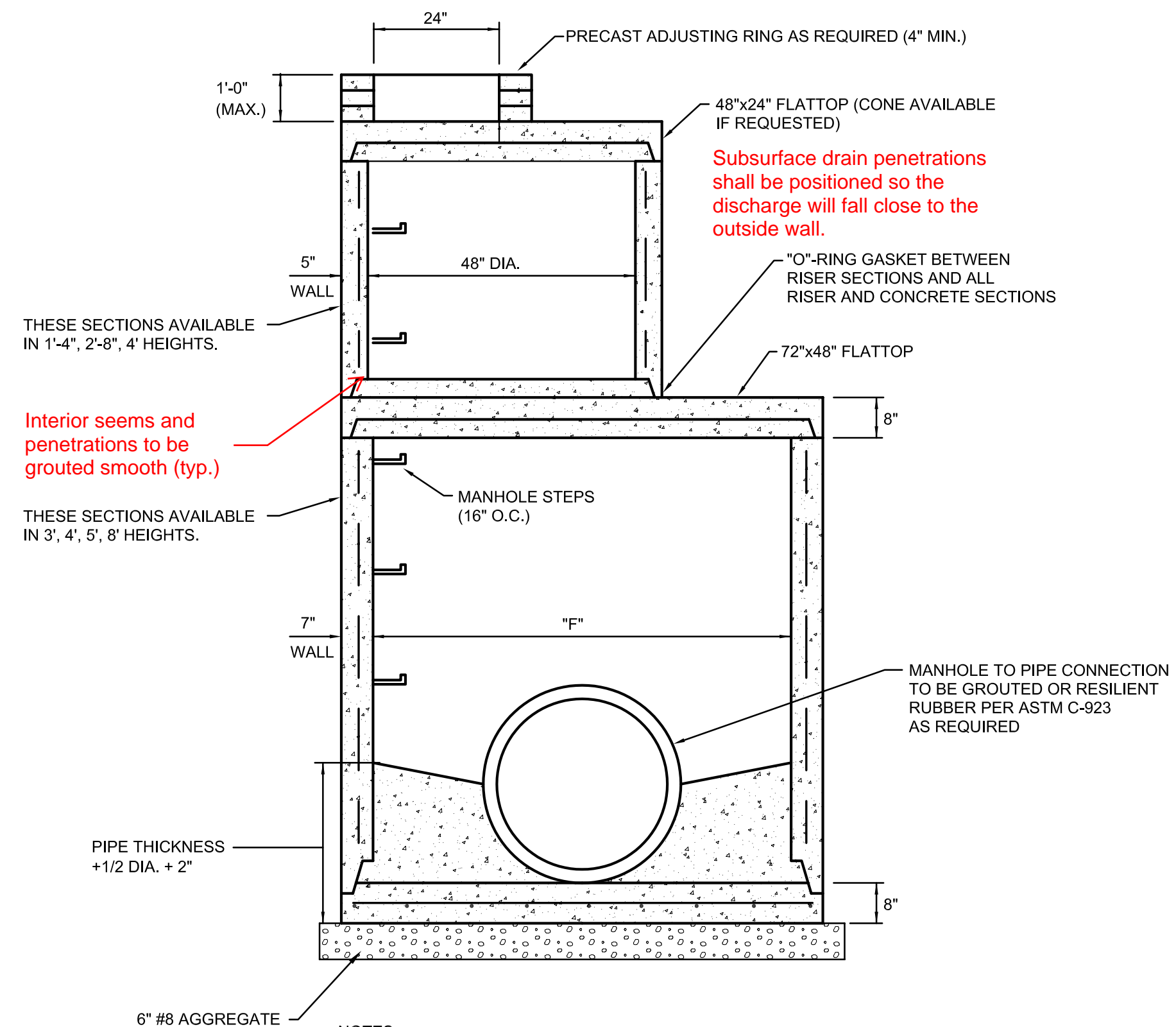

- NOTES:
- 1.) MANHOLE CONFORMS TO A.S.T.M. C-478.
  - 2.) TONGUE AND GROOVE JOINT WITH MASTIC, BUTYL ROPE OR GASKETED PER ASTM C-443 AS REQUIRED.

MANHOLE TYPE	MANHOLE DIAMETER "F"	MAXIMUM PIPE SIZE	
		PIPE ENTERING / PIPE EXITING AT 0°-45° BEND	PIPE ENTERING / PIPE EXITING AT 45°-90° BEND
J	60"	36"	33"
K	72"	48"	36"
L	96"	54"	48"
M	102"	72"	66"
N	108"	84"	72"

**STORM MANHOLES TYPE "J - K - L - M & N"**  
NOT TO SCALE

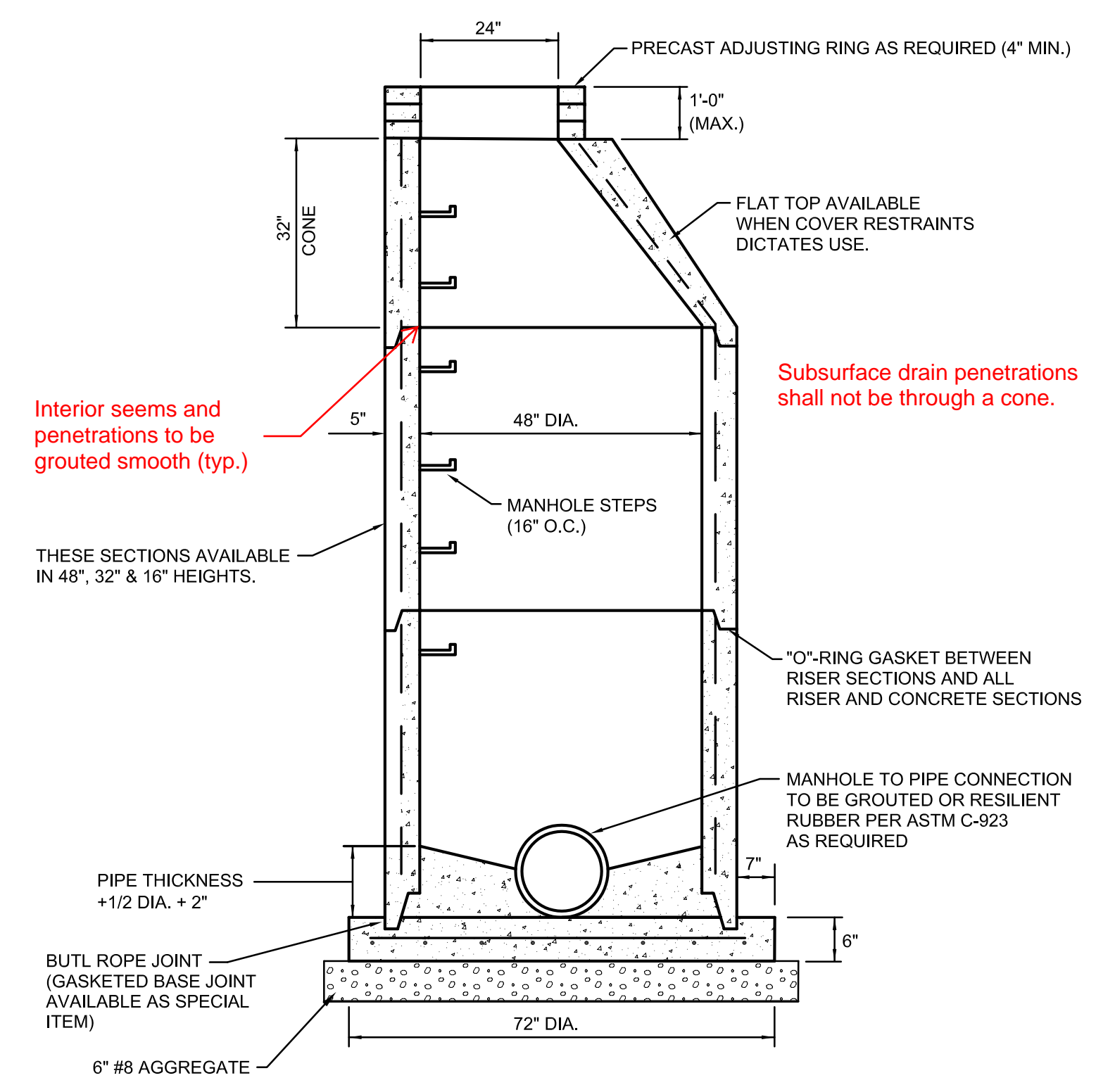

- NOTE:
- 1.) MANHOLE CONFORMS TO A.S.T.M. C-478.

MAXIMUM PIPE SIZE	
PIPE ENTERING / PIPE EXITING AT 0°-45° BEND	24"
PIPE ENTERING / PIPE EXITING AT 45°-90° BEND	21"

**STORM MANHOLES TYPE "C"**  
NOT TO SCALE

**MANHOLE NOTES:**

- 1.) Type "J, K, L, M & N" manholes as detailed hereon require a certain minimum depth. In cases where the depth of the storm sewer is not sufficient to meet the minimum depth as by the detail, "F" diameter manhole section may be used required by the detail, "F" diameter manhole section may be used throughout the depth of the manhole.
  - 2.) Manholes shall conform to ASTM C-478. Joints shall conform to ASTM C-443. The use of cast-in-place concrete structures shall require the prior written approval of the Town Engineer. Regardless of the type of casting used, the casting shall be centered over the manhole steps.
  - 3.) Manhole steps shall be made from a steel reinforcing rod encapsulated in a copolymer polypropylene resin. The manhole steps shall equal or exceed OSHA requirements manhole steps, **PS1-PF as manufactured by M.A. Industries, Inc. Peachtree City, Georgia, or approved equal.**
- STORM SEWER TELEVISION:**
- 1.) All storm lines 12" in diameter and greater upon completion and 3 months prior to the expiration of the maintenance bond shall be televised. Smaller lines may be required to be televised by the Town Engineer at his discretion if it is necessary to ensure proper installation and/or operation. The storm sewer shall also be jetted clean if necessary in the judgment of the Town's representative after observing the televising.

**CASTING NOTES:**

- 1.) Castings which drain combined curb and gutter, Type II curbing shall be Neenah R-3286-8V or Neenah R-3287-10V or as approved by the Town Engineer. Manholes shall not be used to drain combined curb and gutter, Type II curbing. **East Jordan 7495 is also acceptable.**
- 2.) Castings which drain roll curb and gutter, Type I curbing shall be Neenah R-3501-TR, or Neenah R-3501-TL or as approved by the Town Engineer. Manholes shall not be used to drain roll curb and gutter, Type I curbing. **East Jordan 7495 is also acceptable.**
- 3.) Castings for inlets which drain open pavement areas without curbing shall be Neenah R-3402-E or as approved by the Town Engineer. **East Jordan 7495 is also acceptable.**
- 4.) Castings for manholes which drain open pavement areas without curbing shall be Neenah R-2501 or as approved by the Town Engineer. **East Jordan 7495 is also acceptable.**
- 5.) Castings for use on inlets or manholes which drain swales or dry bottom detention basins shall be Neenah R-2560 or as approved by the Town Engineer. **East Jordan 7495 is also acceptable.**
- 6.) Castings for manholes which do not collect surface water shall be Neenah R-1772-A or as approved by the Town Engineer. **East Jordan 1022-Z1 is also acceptable.**
- 7.) All castings shall be stamped "DUMP NO WASTE".

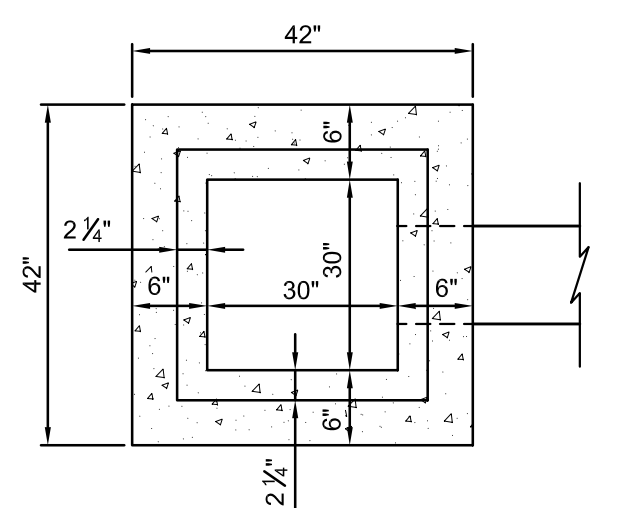

Minimum dimension for curb inlet is 30" x 30"

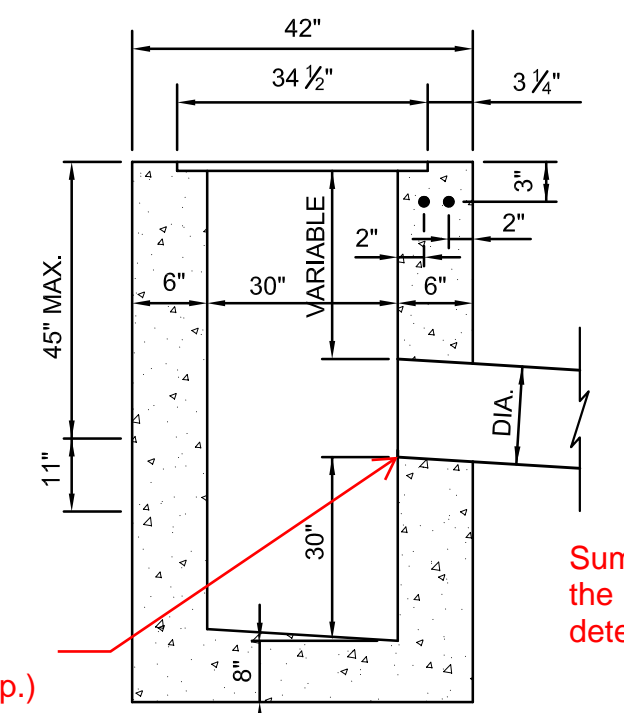

- NOTE:
- 1.) STRUCTURE SHALL COMPLY WITH INDOT SPECIFICATIONS
  - 2.) MINIMUM CONCRETE COMPRESSIVE STRENGTH 4000 PSI
  - 3.) MAXIMUM OF FOUR 2" ADJUSTING SECTIONS, STRIKE CLEAN INSIDE

Interior seams and penetrations to be grouted smooth (typ.)

**Curb inlet CATCH BASIN**  
NOT TO SCALE

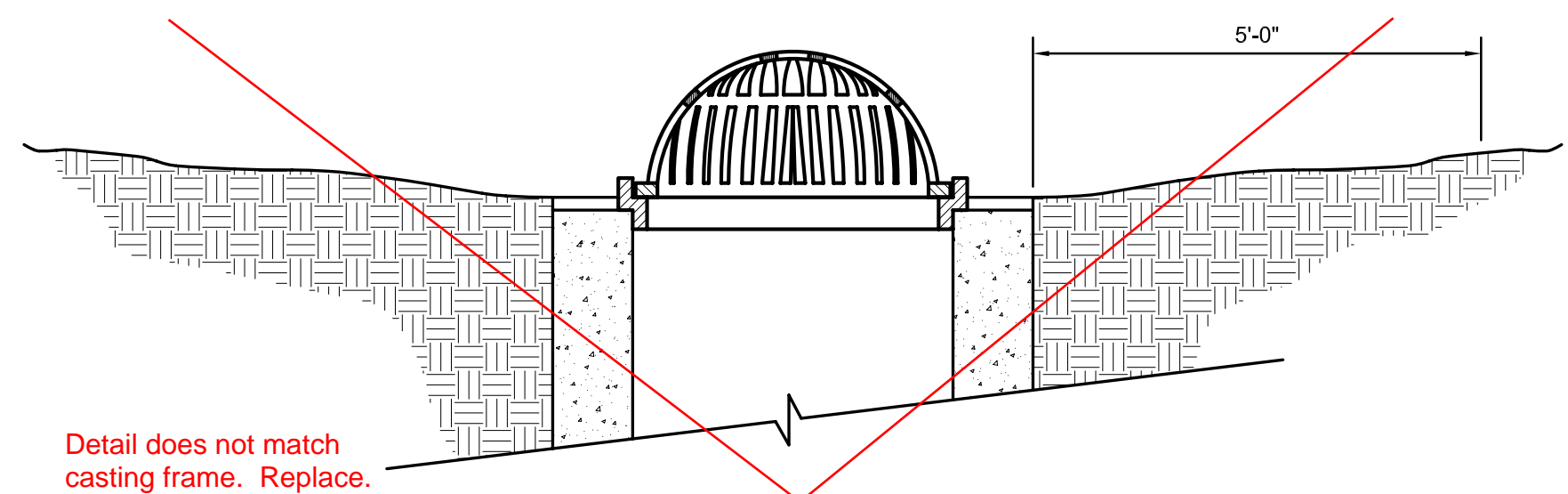

Detail does not match casting frame. Replace.

NOTE: ALL CASTINGS SHALL BE STAMPED "DUMP NO WASTE"

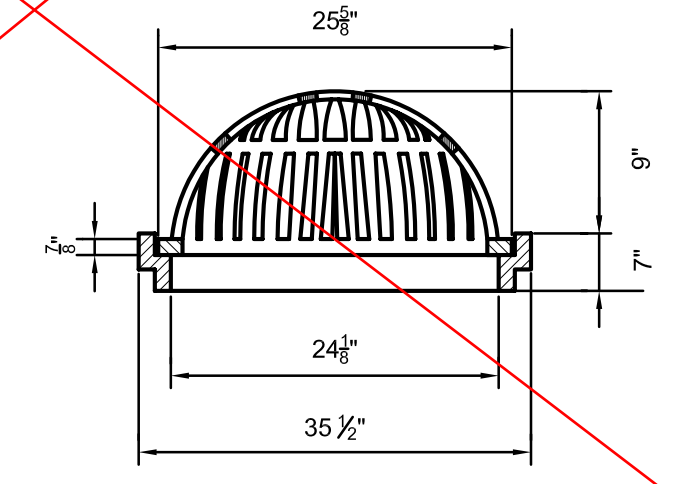

**BEEHIVE GRATE CASTING WITH FRAME - NEENAH R-2560-E2**  
NOT TO SCALE

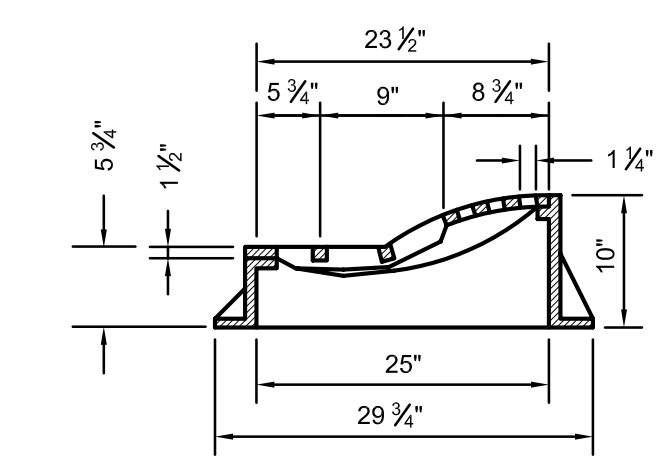
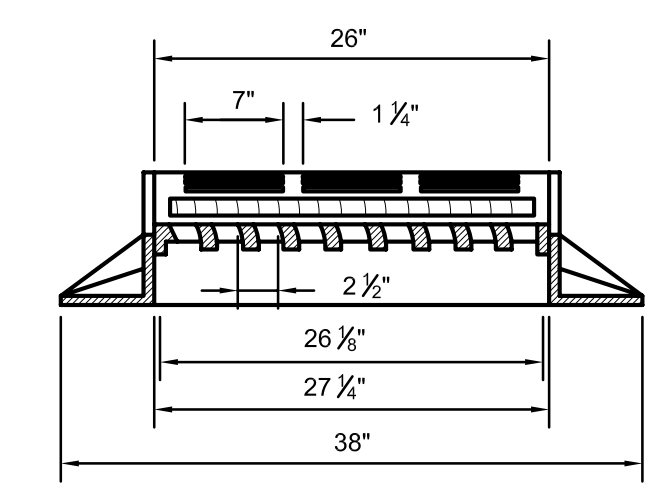

NOTE: ALL CASTINGS SHALL BE STAMPED "DUMP NO WASTE"

**R-3501-T(L&R) NEENAH CURB INLET FRAME, GRATE & CURB BOX DETAIL**  
NOT TO SCALE

CATALOG NO.	D	Wt. Lbs.
R-1772	25"	250
R-1772-A	25"	285

HEAVY DUTY  
FURNISHED WITH PLATEN LID, SIMILAR TO R-1706-1

NOTE: ALL CASTINGS SHALL BE STAMPED "DUMP NO WASTE"

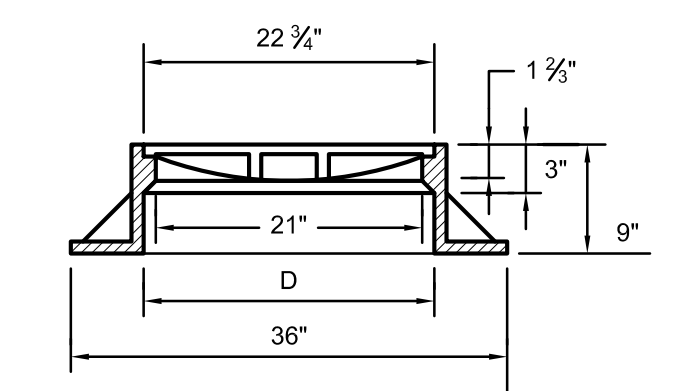

**STORM MANHOLE R-1772-A WITH CONCEALED PICK HOLES**  
NOT TO SCALE

REVISIONS		
REV. NO.	DESCRIPTION	DATE
1	Various changes in red	4/18/2023

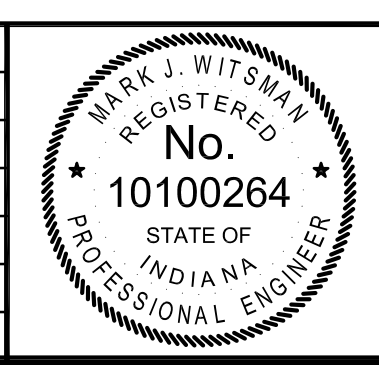

RECOMMEND FOR APPROVAL	<i>Mark J. Witsman</i>	DESIGN ENGINEER	7/12/05	DATE
APPROVED	<i>Ronald D. Coyle</i>	PUBLIC WORKS COMMISSIONER	7/12/05	DATE
APPROVED	<i>Mark J. Witsman</i>	TOWN COUNCIL PRESIDENT	7/12/05	DATE

<b>TOWN OF McCORDSVILLE</b>	<b>TOWN STANDARDS STORM SEWER STRUCTURE DETAILS</b>	<b>SHEET</b>
		<b>6 OF 10</b>

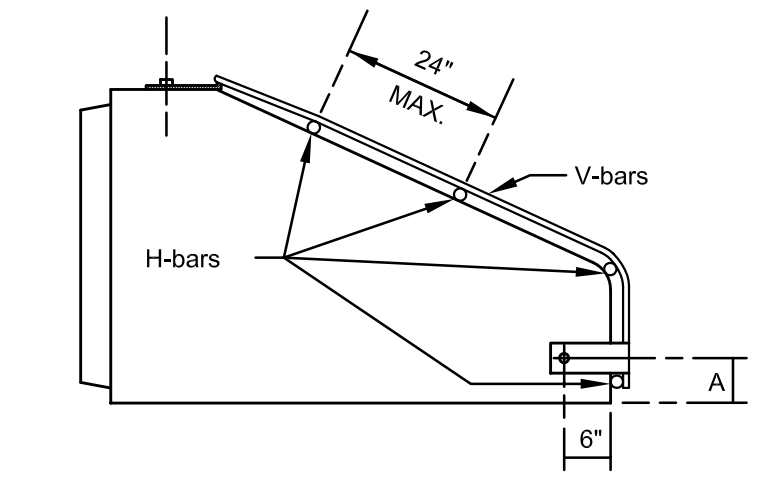
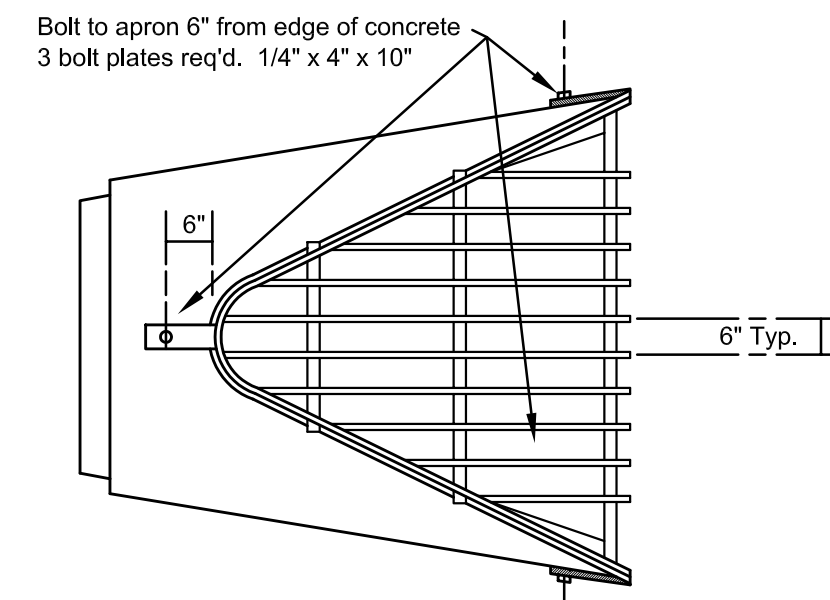

- NOTES:**
1. BARS & PLATES ARE HOT-ROLLED STEEL.
  2. BARS, PLATES & PIPE ARE FINISHED WITH 2 COATS OF ALUMINUM PAINT.
  3. BOLTS ARE GALVANIZED.
  4. SEE STD. PLATES A-10 & A-11 FOR APRON DIMENSIONS.
  5. TRASH GUARDS WITH DIFFERENT DIAMETER BARS ARE AVAILABLE, SPECIAL ORDER.

**TRASH GUARDS FOR CONCRETE APRONS**  
NOT TO SCALE

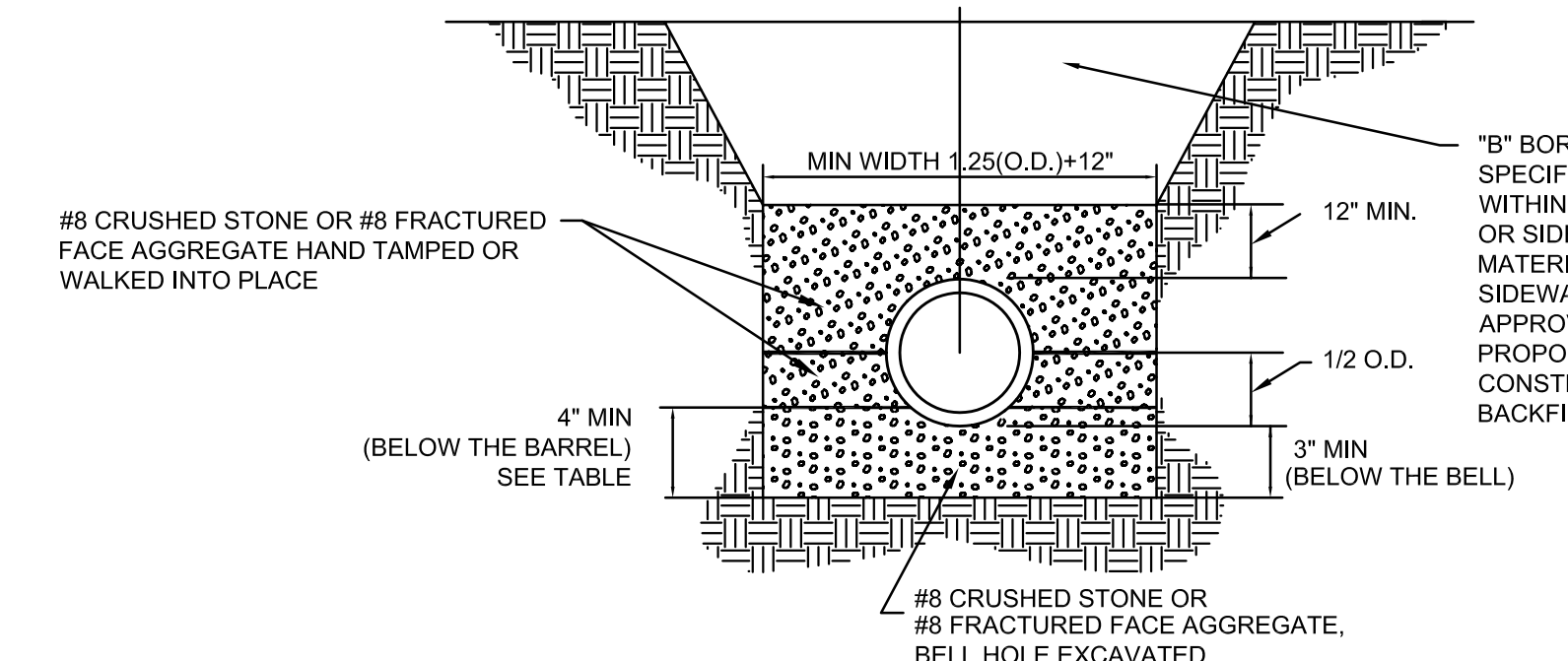

PIPE SIZE	8"-15"	18" & OVER
BEDDING BELOW THE PIPE BARREL	O.D./4 MIN=4"	O.D./4 MAX=8"

**FLEXIBLE PIPE (HDPE & PVC) TRENCH DETAIL**  
NOT TO SCALE

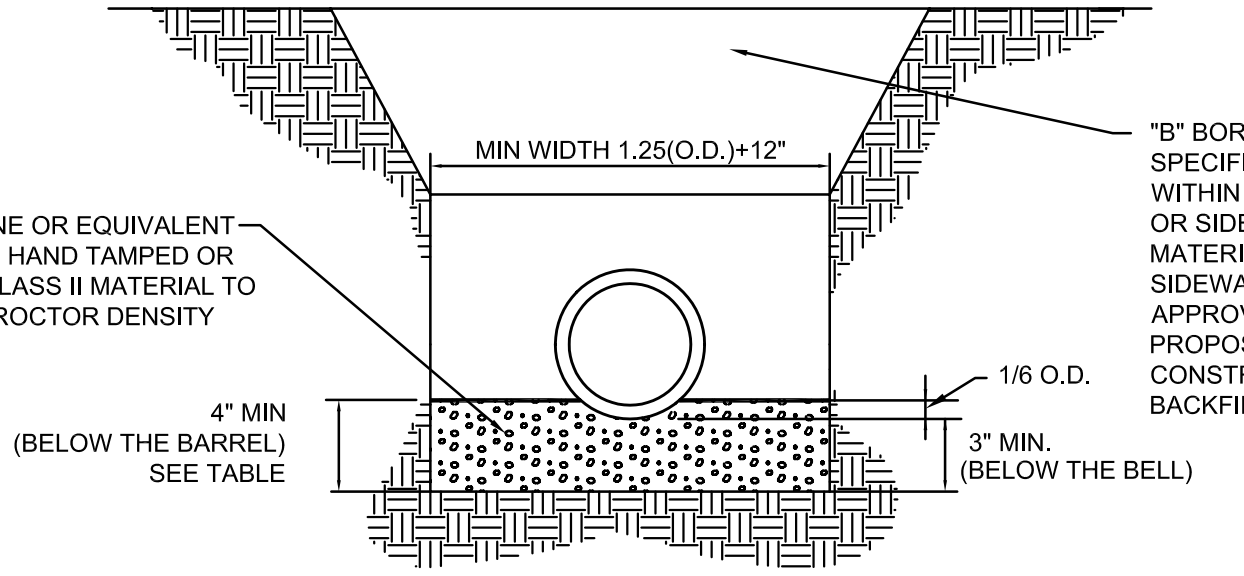

PIPE SIZE	8"-15"	18" & OVER
BEDDING BELOW THE PIPE BARREL	O.D./4 MIN=4"	O.D./4 MAX=8"

**RIDGID PIPE (RCP) TRENCH DETAIL**  
NOT TO SCALE

DIA.	WALL	G or T	WT. SEC	A	B	C	D	E	DIA. H	R-1	R-2	SKIRT
12	2	1 1/2	530	4	24	48 1/8	72 7/8	24	13	10 1/16	9	3 1/2
15	2 1/4	2	740	6	27	46	73	30	16	12 1/2	11	3 1/2
18	2 1/2	2 1/2	990	9	27	46	73	36	19	15 1/2	12	4
21	2 3/4	2 1/4	1280	9	35	38	73	42	22	16 1/8	13	4
24	3	2 1/2	1520	9 1/2	43 1/2	30	73 1/2	48	25	16 11/16	14	4 1/2
27	3 1/4	2 1/2	1930	10 1/2	48	25 1/2	73 1/2	54	28	17 3/4	14 1/2	4 1/2
30	3 1/2	3	2190	12	54	19 3/4	73 3/4	60	31	18 5/16	15	5
33	3 3/4	3 3/8	3150	13 1/3	58 1/2	39 1/4	97 3/4	66	34	23 3/4	17 1/2	5 1/2
36	4	3 1/2	4100	15	63	34 3/4	97 3/4	72	37	24 1/16	20	5 1/2
42	4 1/2	3 3/4	5380	21	63	35	98	78	43	27 1/4	22	5 1/2
48	5	4 1/4	6550	24	72	26	98	84	49	28 1/8	22	5 3/4
54	5 1/2	4 3/4	8040	27	65	35	100	90	55	32 7/8	24	6 1/4
60	6	5	8750	30	60	39	99	96	61	36 3/4	24	6 3/4
66	6 1/2	5 1/2	10630	24	78	21	99	102	67	35 11/16	24	7 1/4
72	7	6	12520	34	78	21	99	108	73	38 5/8	24	7 3/4
78	7 1/2	6 1/2	14430	24	78	21	99	114	79	41 15/16	24	8 1/2
84	8	7	16350	24	78	21	99	120	85	44 13/16	24	9

NOTES: 1. MANUFACTURE OF END SECTION IS IN ACCORDANCE WITH APPLICABLE PORTIONS OF A.S.T.M. SPECIFICATION C76.

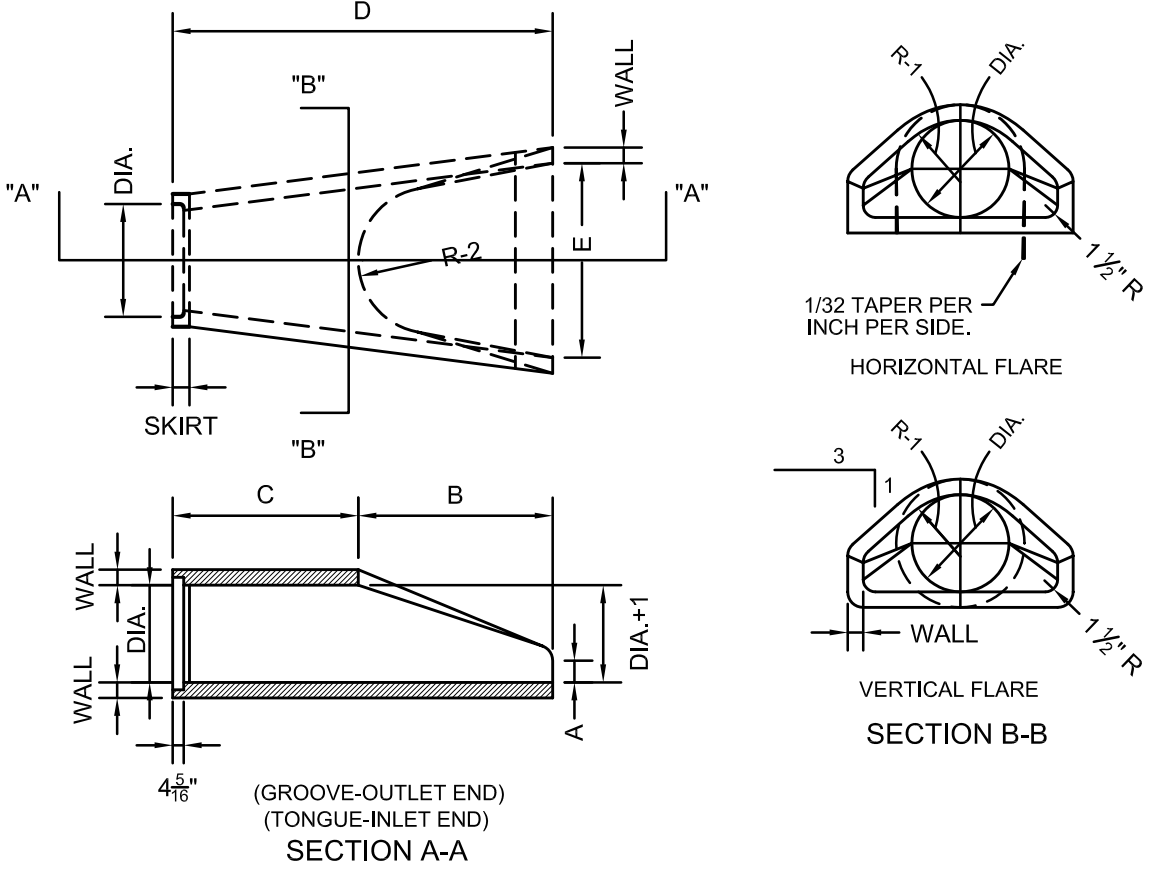

**PRECAST CONCRETE END SECTION DETAIL**  
NOT TO SCALE

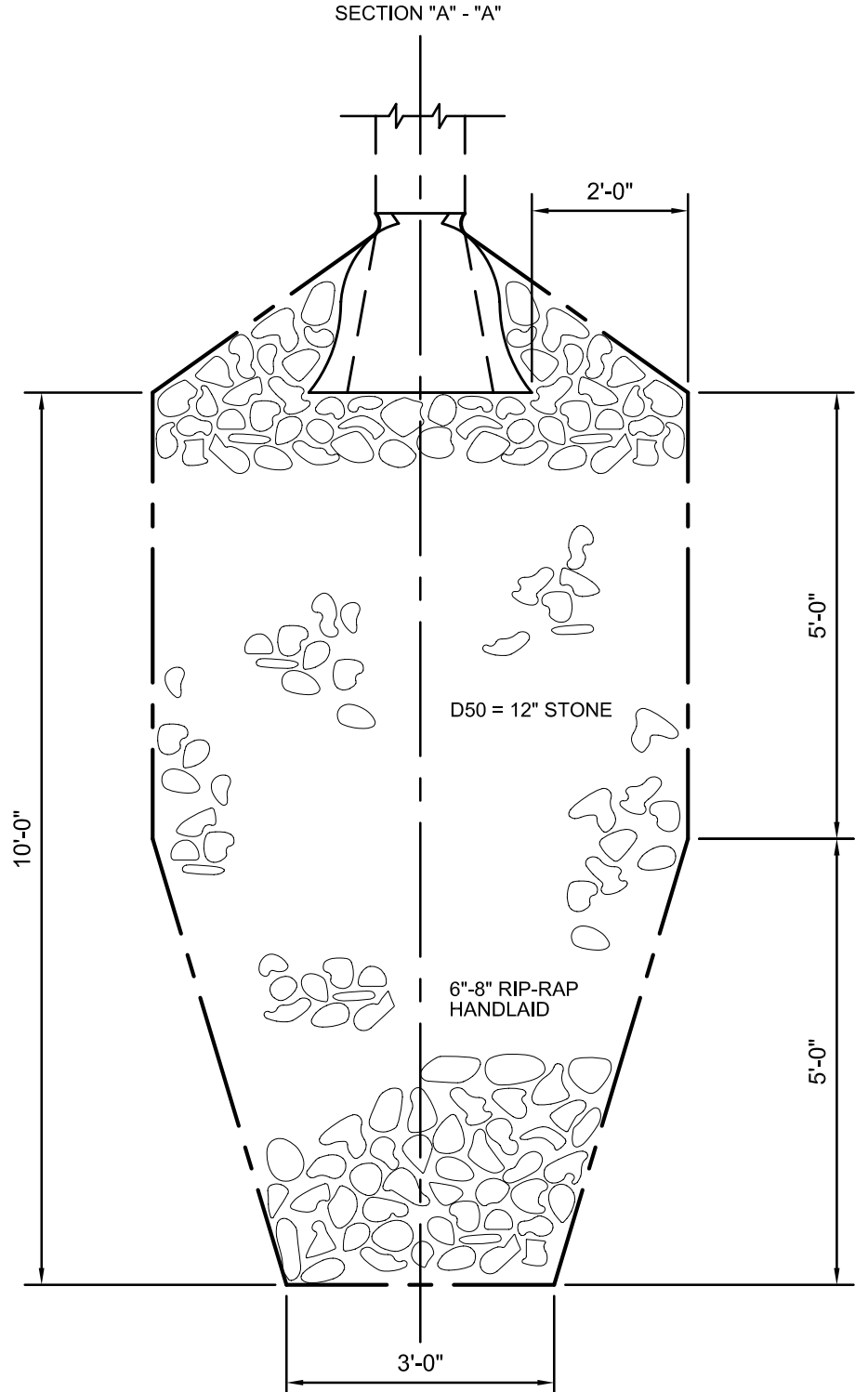

**RIP-RAP DETAIL**  
NOT TO SCALE

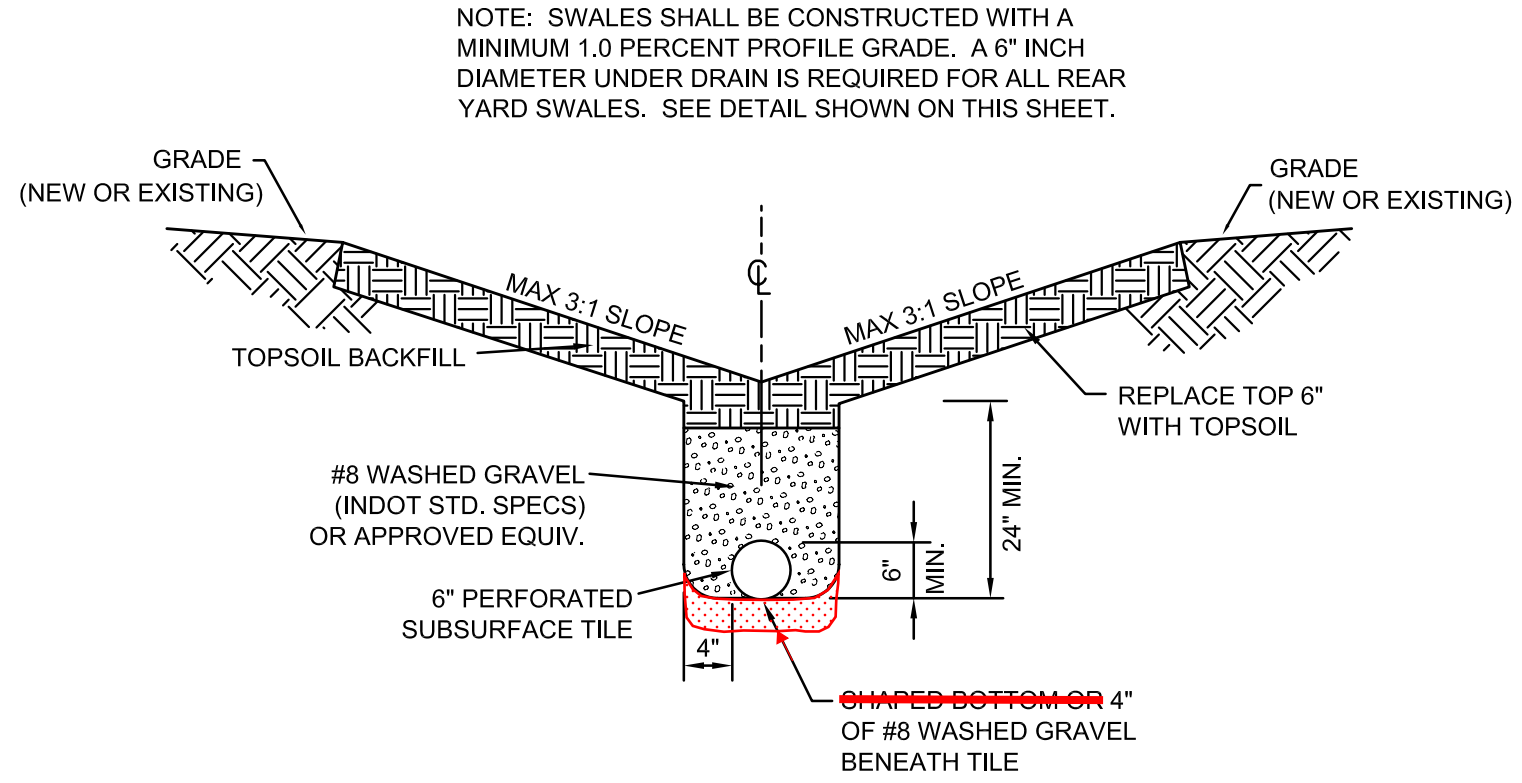
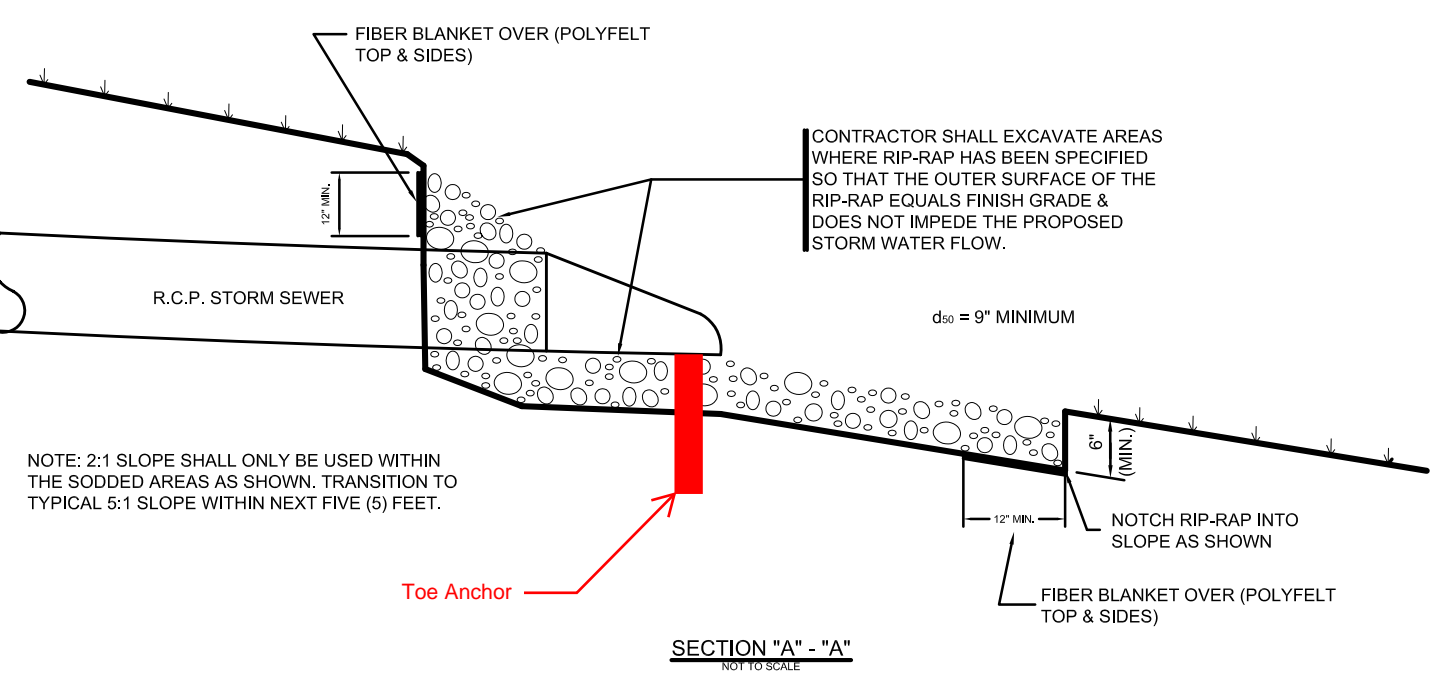

**SWALE UNDERDRAIN DETAIL**  
NOT TO SCALE

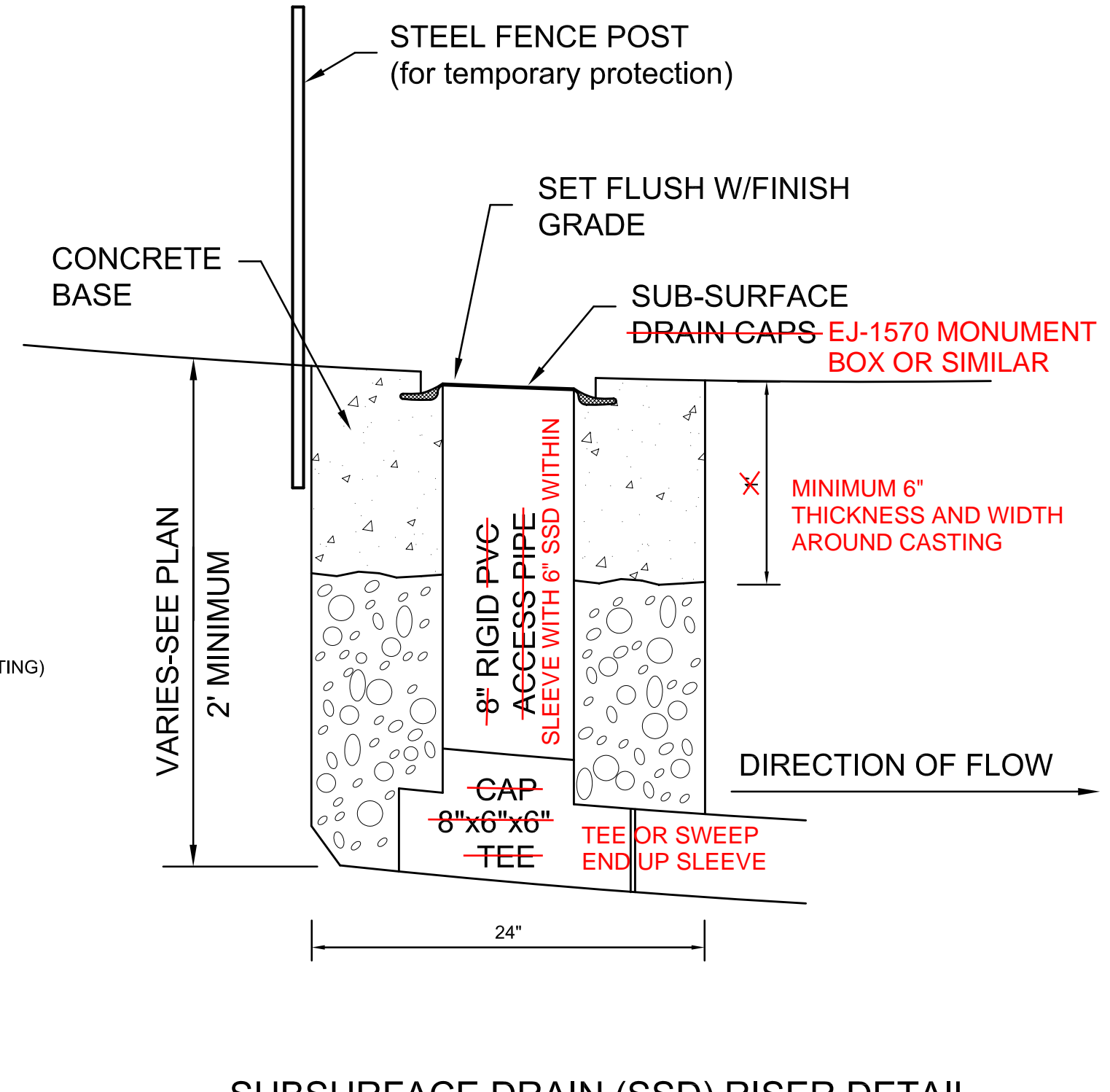

**SUBSURFACE DRAIN (SSD) RISER DETAIL**  
NOT TO SCALE

REVISIONS		
REV. NO.	DESCRIPTION	DATE
1	Various changes in red	4/18/2023

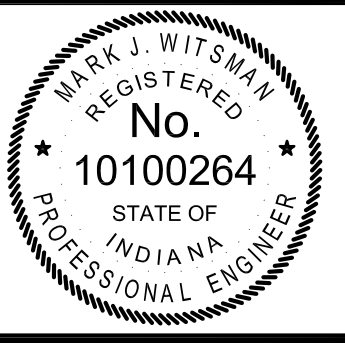

RECOMMEND FOR APPROVAL	<i>Mark J. Witsman</i>	DESIGN ENGINEER	7/12/05	DATE
APPROVED	<i>Ronald D. Coyle</i>	PUBLIC WORKS COMMISSIONER	7/12/05	DATE
APPROVED	<i>Mark J. Witsman</i>	TOWN COUNCIL PRESIDENT	7/12/05	DATE

**TOWN OF McCORDSVILLE**  
**TOWN STANDARDS**  
**STORM SEWER BEDDING**  
**DETAILS AND GENERAL NOTES**

**SHEET**  
**7**  
**OF**  
**10**

**GENERAL NOTES**

- 1.) Sanitary sewer pipe of other material not meeting Town of McCordsville Standards shall require the prior written approval of the Town Engineer.
- 2.) The Contractor shall submit information to the Town Engineer showing conformance with these specifications upon request.
- 3.) Forty-eight (48) hours notice shall be given to the Town Engineer prior to the start of sewer construction and prior to any testing.
- 4.) The contractor shall be responsible for verifying that all state highways, city, and county permits have been obtained by the developer prior to start of construction.
- 5.) Backfill around all structures and all cuts under paved areas with B-barrow as defined by current INDOT specifications. Trenches opening within 5-feet of paved roadways shall be backfilled with B-barrow as defined by current INDOT specifications. Backfill under sidewalks shall be B-barrow; unless the walks are constructed a minimum of 6 months after backfill has been in place. The Town of McCordsville may require an analysis of the B-barrow to confirm its compliance with INDOT specifications at the contractor's expense.
- 6.) Water and sewer line crossings and separations shall be in accordance with 327 IAC 3-6-9.
- 7.) Trench shall be opened sufficiently ahead of pipe laying to reveal obstruction, and shall be properly protected and/or barricaded when left unattended.
- 8.) No water shall be permitted to flow into the sanitary sewer system during construction. The contractor shall utilize a pump to keep the water level below the pipe. Pump discharge shall be directed to a storm outlet in accordance with local, state and federal laws and regulations. Any pipe entering existing sewers shall be plugged with screw type mechanical, braced plug and tied in place until such time as all tests on the sewers have been completed and the lines have passed all punch lists.
- 9.) The contractor shall use a laser and target wherever possible to insure proper construction at the planned grade.
- 10.) The contractor shall provide measurements of the slope of the sewer for each manhole section as construction progresses. Such measurements shall be certified by a registered land surveyor or engineer and be available on-site for observation by the Town Engineer. No more than three manhole sections can be constructed in advance of such measurements.
- 11.) The contractor shall be required to furnish the developer's engineer with a set of prints, marked in red pencil, showing actual sewer location and invert, to include lateral location, depth and length. Such asbuilt prints must be received by the developer's engineer before the final contract payment can be authorized. The sanitary sewer laterals and stubs termination shall be indicated on the surface with a 2"x4" wood board or other appropriate marker set immediately above the said termination point.
- 12.) Record drawings shall be provided to the Town Engineer for review and approval. Once approved, two copies and electronic images of the approved record drawings will be provided. The electronic images will be in an acceptable format approved by the Town Engineer. A site plan in state plane coordinates compatible with the Hancock County GIS system will also be provided with the electronic files showing the property lines, easements, streets and right-of-ways and as-built locations of the sanitary sewer, storm sewer and water lines.

**SANITARY SEWER PIPE**

- 1.) Sanitary sewer pipe between 6 and 15 inches in diameter shall be SDR 35 PVC in accordance with ASTM D3034 and ASTM 2321. Sanitary sewer pipe buried 15 feet or greater shall be SDR 26 PVC in accordance with ASTM D3034. PVC pipe shall have grooved bell and gasket. The pipe shall be made of PVC plastic in accordance with ASTM D1784.
- 2.) Sanitary sewer pipe greater than 15 inches in diameter shall be either:
  - a. PVC SDR 35 in accordance with ASTM D3034 and ASTM 2321. PVC pipe shall have grooved bell and gasket. The pipe shall be made of PVC plastic as defined in ASTM D1784. Sanitary sewer pipe buried 15 feet or greater shall be SDR 26 PVC in accordance with ASTM D3034.
  - b. Profile sewer in accordance with ASTM F949. The pipe and fittings shall have a minimum cell classification of 12454 in accordance with ASTM D1784. The joints shall be push-on bell and spigot type using elastomeric ring gaskets conforming to ASTM D3212 and ASTM F477. The pipe shall have a minimum stiffness of 46 PSI when measured in accordance with ASTM D2412. Profile sewer pipe is not permitted at depths 15 feet or greater.
- 3.) PVC sewer fittings shall be SDR 26 in accordance with ASTM D3034. Fittings in sizes through 8-inches shall be molded in one piece with elastomeric joints and minimum socket depths as specified in sections 6.2 and 7.3.2. Fittings 10-inches and larger shall be molded or fabricated in accordance with section 7.11 with manufacturers standard pipe bells and gaskets. Gaskets for elastomeric joints shall be molded with a minimum cross-sectional area of 0.20 square inches and conform to ASTM F-477 specification.
- 4.) The minimum slope for sewer acceptance by the Town of McCordsville are:
 

Size of pipe	Minimum constructed slope
8-inch	0.40%
10-inch	0.28%
12-inch	0.22%
15-inch	0.15%
18-inch	0.12%
21-inch	0.10%
24-inch	0.08%

In the event the contractor does not meet the minimum slopes, the sewer section and any other affected sewer sections shall be reconstructed to meet such minimum slopes.

**SANITARY SEWER LATERALS OUTSIDE OF THE RIGHT OF WAY/EASEMENT**

- 1.) Only approved contractors may install sewer laterals. Contractors must provide proof of liability insurance and a reference list for consideration to be added to the approved list.
- 2.) If working within an existing right-of-way, the contractor must obtain a right-of-way permit from the appropriate local jurisdiction.
- 3.) Contractors are responsible for obtaining all appropriate permits prior to construction. No deviations from the approved plot plan are permitted unless instructed by the Office of Public Works. Immediately notify the office of Public Works of any conflicts or discrepancies noted on the approved plot plan. It is the sole responsibility of the owner to ensure all contractors and subcontractors comply with the approved plot plan. A copy of the approved plot plan is to be provided to the Inspector at the time of inspection.
- 4.) The portion of the lateral installed from the right-of-way/easement to the building shall be inspected by the Office of Public Works prior to being backfilled.
- 5.) Lateral inspections shall be scheduled forty-eight (48) hours in advance with the Office of Public Works.
- 6.) A 6" diameter pipe Type I clean out shall be installed 3' away from building. A threaded plug shall be used to ensure the pipe is 100% watertight. For laterals greater than 100 LF as measured along the pipe, clean outs shall be installed at the right-of-way or property line or at 100 foot increments to provide access every 100 feet.
- 7.) Clean outs are not to be installed in sidewalks, driveways, or any other paved or unpaved traffic areas or pedestrian paths.
- 8.) All clean outs except within 3 feet of the building are to be Type II cleanouts.
- 9.) The connection of the building plumbing to the lateral shall be made with a fernco coupling within three (3) feet of the building before the cleanout except when the building has a basement. If the connection is made at the basement and there is not an adjacent slab or craw space, then a glued joint connection shall be made.
- 10.) The connection point shall not be made under porches or foundations.
- 11.) The fernco coupling shall be sealed watertight using steel band clamps. The piping on either side of the connection point shall be aligned and have no offsets or angles.

**SANITARY SEWER LATERALS - GENERAL NOTES**

- 1.) Laterals are to be constructed to the right-of-way/easement line and plugged tight with a braced plastic disc or cap capable of withstanding a low pressure air test without leakage. Only after the sanitary sewer has been tested and accepted by the Town Engineer is further installation of the laterals outside the right-of-way/easement permitted.
- 2.) Normal lateral slope is 1/4" per foot. Minimum lateral slope is 1/8" per foot. Any areas found not to comply with the minimum slope shall be removed and reinstalled.
- 3.) Lateral pipe shall be a minimum of 6" diameter and shall be SDR 35 PVC in accordance with ASTM D3034 and ASTM 2321. Laterals with any portion buried 15 feet or greater shall be SDR 26 PVC in accordance with ASTM D3034 to the terminus point either the right-of-way or easement line. PVC pipe shall have grooved bell and gasket. The pipe shall be made of PVC plastic conforming to ASTM D1784. Size and conformance shall be clearly labeled on pipe for inspection.
- 4.) All PVC sewer fittings shall be SDR 26 in accordance with ASTM D3034. Fittings shall be molded in one piece with elastomeric joints and minimum socket depths as specified in sections 6.2 and 7.3.2. Gaskets for elastomeric joints shall be molded with a minimum cross-sectional area of 0.20 square inches and conform to ASTM F-477 specification.
- 5.) All sewer laterals shall be bedded the same as the main line sewer. A minimum D/4 or 6-inches of compacted #8 stone under the pipe, 6-inches on either side of the pipe, and 12" above the pipe are required.
- 6.) Laterals are not to be installed under driveways.
- 7.) Full depth granular backfill is required for the lateral trench in areas within five (5) feet of drive ways, sidewalks or other traffic areas.
- 8.) Laterals are to be traced along the top of the pipe with a minimum size of 14 gauge wire from the wye to the clean out within three (3) feet of the building and extended above grade. The contractor will install the tracer wire utilizing a method does not require any splices in the tracer wire. The tracer wire will be mounted to the top of the pipe in at least three locations along each stick of pipe. Any splices that become necessary during construction will be sealed water tight.
- 9.) Laterals will be separated from water mains and water service lines by ten (10) feet when measured horizontally from the outside edge of the lateral to the outside edge of any existing or proposed water mains or water service lines except when crossing water mains or water service lines which shall be separated by eighteen (18) inches when measured vertically. Crossings must be at a minimum angle of 45 degrees.

**SANITARY MANHOLES AND CASTINGS**

- 1.) All sanitary manholes shall be precast concrete manholes in accordance with ASTM C-478 and section 720. O-rings shall conform to C-443. Kent seal or approved equal shall also be applied to all joints and between riser rings and castings. Manhole step spacing shall be no more than 16-inches.
- 2.) The casting elevations are set by plan. However, the castings are to be adjusted in the field by the Town's representative should a discrepancy occur between plan grade and existing grade. A new manhole ring and cover shall be installed to establish grade. Maximum height of adjusting rings from the top of the cone to the bottom of the casting shall be 12-inches.
- 3.) Butyl rubber coating shall be applied around each manhole joint from 6-inches above to 6-inches below each joint. The appropriate primer shall be applied prior to applying the double row of kent seal. Each manhole joint will then be wrapped four times with minimum 15 inch wide 80 gage (0.8 mil) polyethylene plastic stretch wrap. Inside joints to be filled with non-shrink grout or precoat plug material.
- 4.) The manhole chimneys, including all riser rings shall be sealed the same as the manhole joints. The butyl rubber and plastic stretch wrap shall extend over the flange of the casting.
- 5.) Manhole castings shall be East Jordan casting 1022-2 or approved equal with a heavy duty self-sealing lid stamped "SANITARY SEWER." Waterproof castings shall be East Jordan casting 1022-2 WT with a heavy duty lid stamped "SANITARY SEWER" or approved equal.

**TESTING**

- 1.) Manholes shall be air tested for leakage in accordance with ASTM C1244-93, standard test method for concrete sewer manholes by the negative air pressure (vacuum) test.
  - a. Installation and operation of vacuum equipment and indicating devices must be in accordance with manufacturer's recommendations and performance specifications which have been provided by the manufacturer and accepted by the engineer.
  - b. With the vacuum tester set in place:
    1. Using a plate testing device, connect the vacuum pump to the outlet port with the valve open.
    2. Draw a vacuum of ten (10) inches of hg. And close the valve.
  - c. Accepted standards for leakage will be established from the elapsed time for a negative pressure change from ten (10) inches to nine (9) inches of mercury. The maximum allowable leakage rate for a four (4) foot diameter manhole must be in accordance with the following:
 

Minimum elapsed time for a manhole depth pressure change of 1 inch hg	
10 feet or less	60 seconds
>10 feet but <15 feet	75 seconds
>15 feet	90 seconds
  - d. If manhole joint sealants are pulled out during the vacuum test, the manhole must be disassembled and the joint sealants replaced.
  - e. Manholes will be subject to visual inspection with all visual leaks being repaired.
- 2.) All sanitary sewer lines upon completion will be required to pass a low pressure air test. The test shall be conducted according to ASTM 1417-92, and witnessed by a representative of the Town of McCordsville. The testing shall be in accordance with Table 1. Add 0.5 psig for each foot of water above the sewer line being tested.
- 3.) Deflection tests shall be performed on all flexible" pipe after the final backfill has been in place at least 30 days. No pipe shall exceed a vertical deflection of 5% deflection test results. (The following are considered non-flexible pipes: concrete pipe, ductile iron pipe, and cast iron pipe). The deflection test shall be performed with a nine-point mandrel. Proving rings shall be available.
- 4.) All sanitary sewer lines upon completion and six months prior to the expiration of the maintenance bond will be televised. The sanitary sewer lines will also be cleaned if necessary in the judgment of the Town's representative after observing the televising tapes.
- 5.) All testing shall be observed by a representative of the Town of McCordsville.

**OIL/GREASE TRAP REQUIREMENTS**

- 1.) All new commercial of industrial entities, which either generate and/or waste oil, grease or their by-products, shall construct a 1,000 gallon (minimum) grease trap. The design engineer shall submit detailed calculations for size justification of the trap. Calculations shall be accompanied with references, specifically denoted origin of sizing calculation method.
- 2.) Toilets, urinals and other similar fixtures shall not waste through the grease interceptor. All other waste shall enter through the grease interceptor, through the inlet pipe only.
- 3.) The grease interceptor and grease trap shall be sized such that it is easily accessible at all times for inspection/sampling and cleaning. The grease trap shall have a minimum of two (2) compartments with fittings designed for grease interception.
- 4.) The oil/ grease trap shall be located outside the building and at a distance far enough to allow soluble grease/oil to become insoluble.

**SPECIFICATION TIME REQUIRED FOR A 0.5 PSIG PRESSURE DROP FOR SIZE AND LENGTH OF PIPE INDICATED FOR Q=0.0015**

1 Pipe Diameter (in.)	2 Minimum Time (sec)	3 Length For Minimum Time (ft)	4 Time for Longer Length (sec)	Specification Time for Length (L) Shown (min:sec)							
				100 ft	150 ft	200 ft	250 ft	300 ft	350 ft	400 ft	450 ft
8	3:47	298	0.760 L	3:47	3:47	3:47	3:47	3:48	4:26	5:04	5:42
10	4:43	239	1.187 L	4:43	4:43	4:43	4:56	5:56	6:55	7:54	8:54
12	5:40	199	1.709 L	5:40	5:40	5:42	7:07	8:32	9:58	11:23	12:49
15	7:05	159	2.671 L	7:05	7:05	8:54	11:07	13:21	15:34	17:48	20:02
18	8:30	133	3.846 L	8:30	9:37	12:49	16:02	19:14	22:26	25:38	28:51
21	9:55	114	5.235 L	9:55	13:05	17:27	21:49	26:11	30:32	34:54	39:16
24	11:23	100	6.846 L	11:23	17:07	22:49	28:31	34:14	39:56	45:38	51:21

For manholes five (5) feet in diameter, add an additional fifteen (15) seconds and for manholes six (6) feet in diameter, add an additional thirty (30) seconds to the time requirements for four (4) foot diameter manholes.

REVISIONS		
REV. NO.	DESCRIPTION	DATE



RECOMMEND FOR APPROVAL	<i>Mark J. Witsman</i> DESIGN ENGINEER	7/12/05 DATE
APPROVED	<i>Ronald D. Coyle</i> PUBLIC WORKS COMMISSIONER	7/12/05 DATE
APPROVED	<i>Mark J. Witsman</i> TOWN COUNCIL PRESIDENT	7/12/05 DATE

<b>TOWN OF McCORDSVILLE</b>	<b>TOWN STANDARDS SANITARY SEWER SPECIFICATIONS</b>	<b>SHEET</b>
		<b>8 OF 10</b>

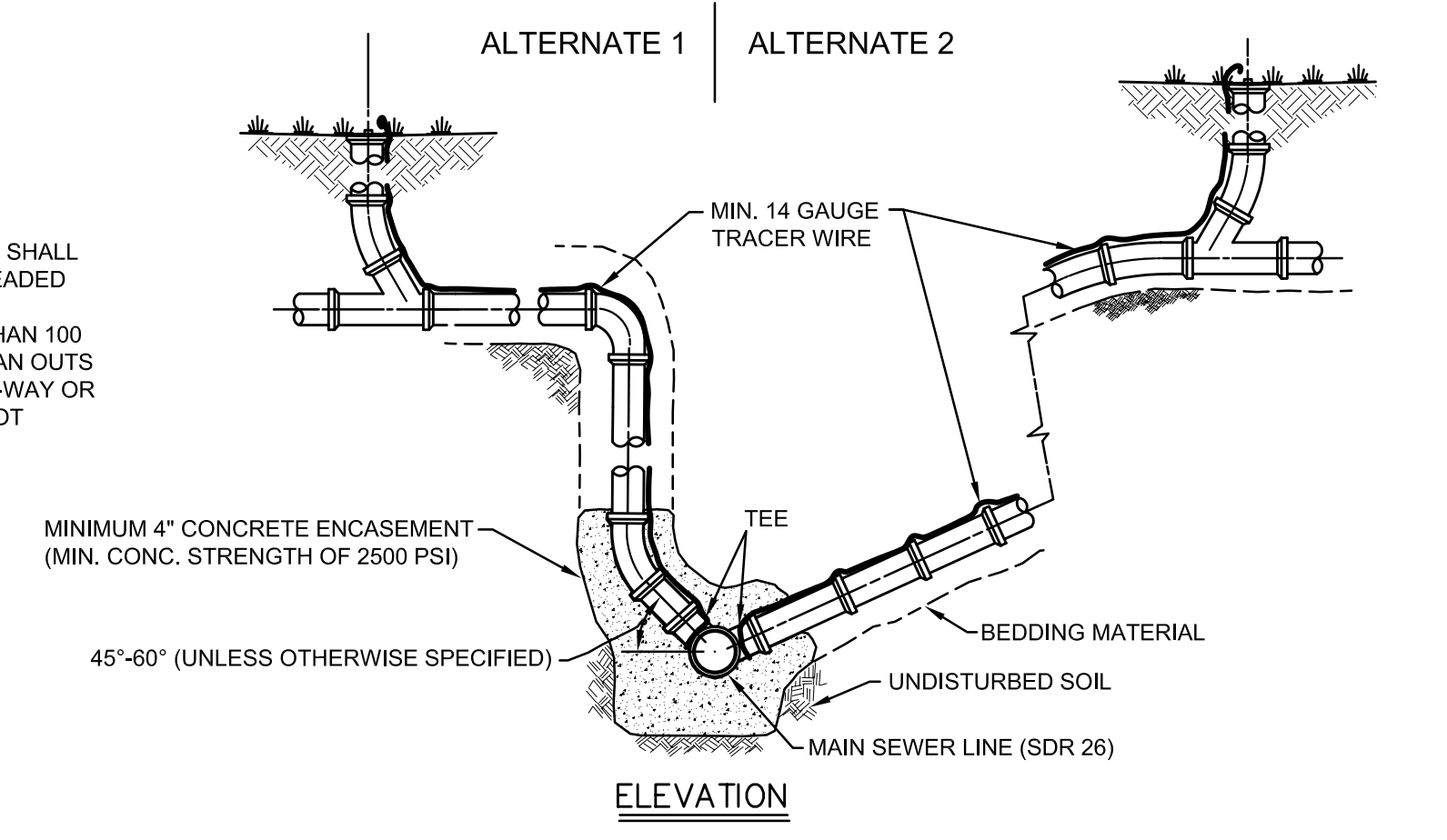
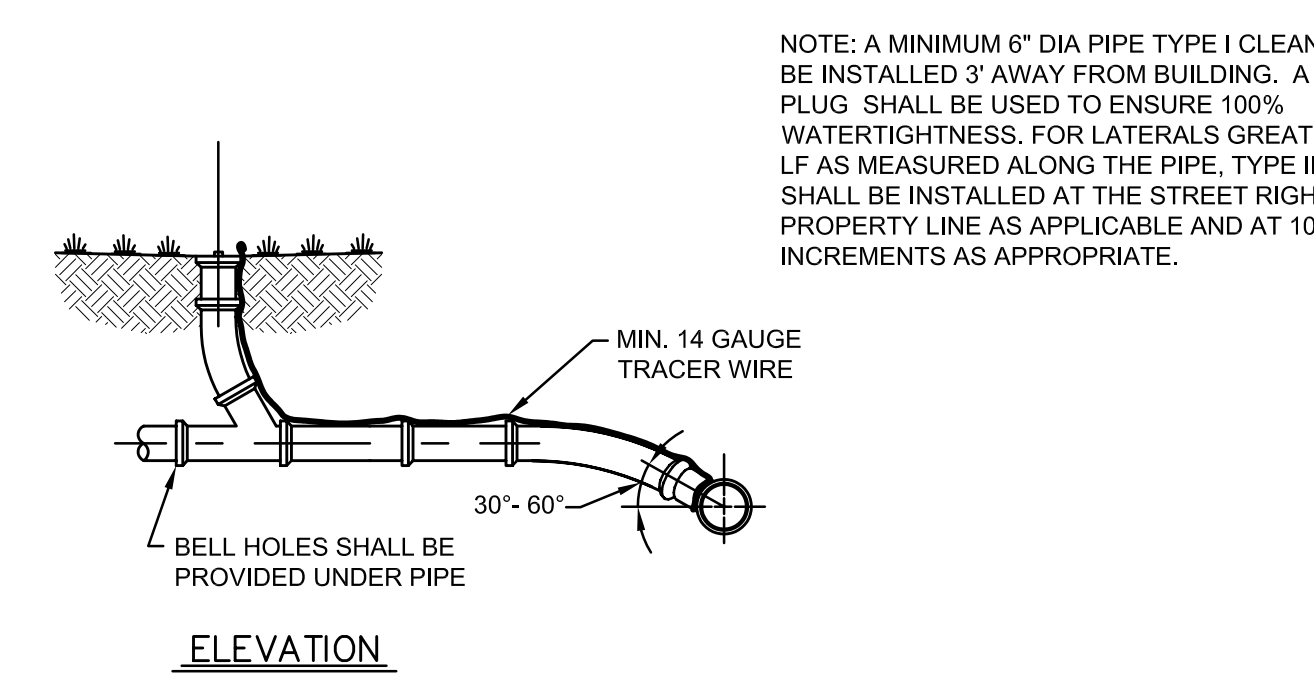
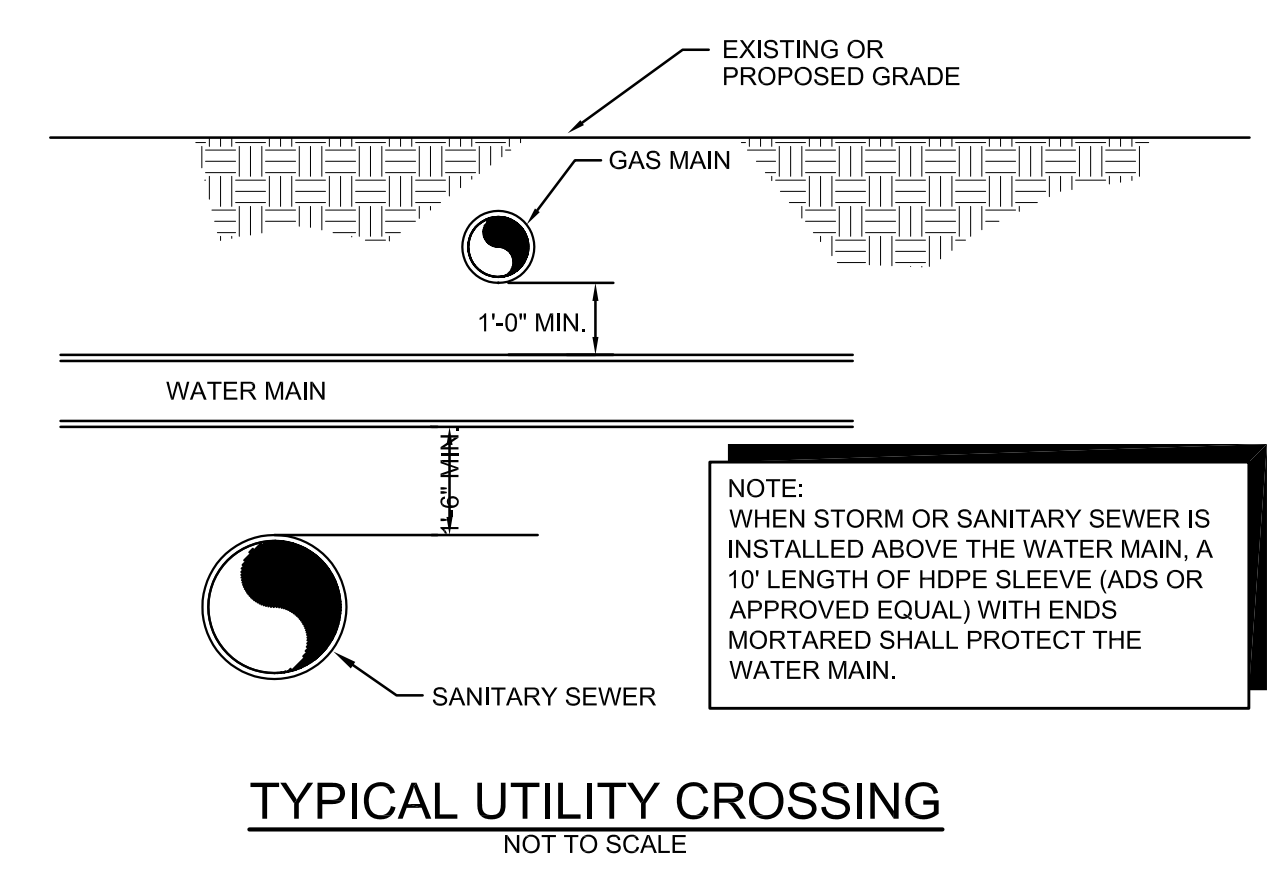
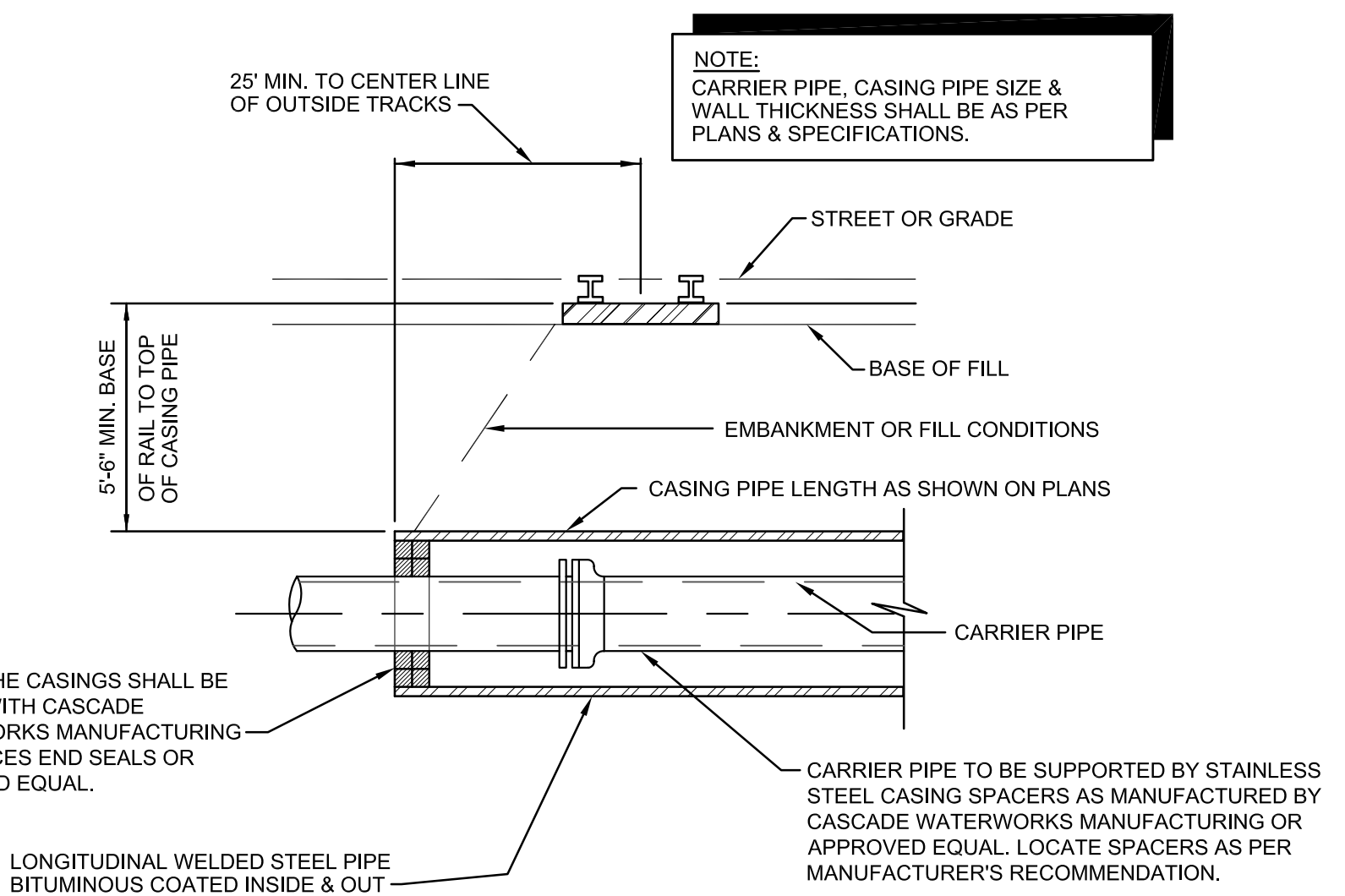
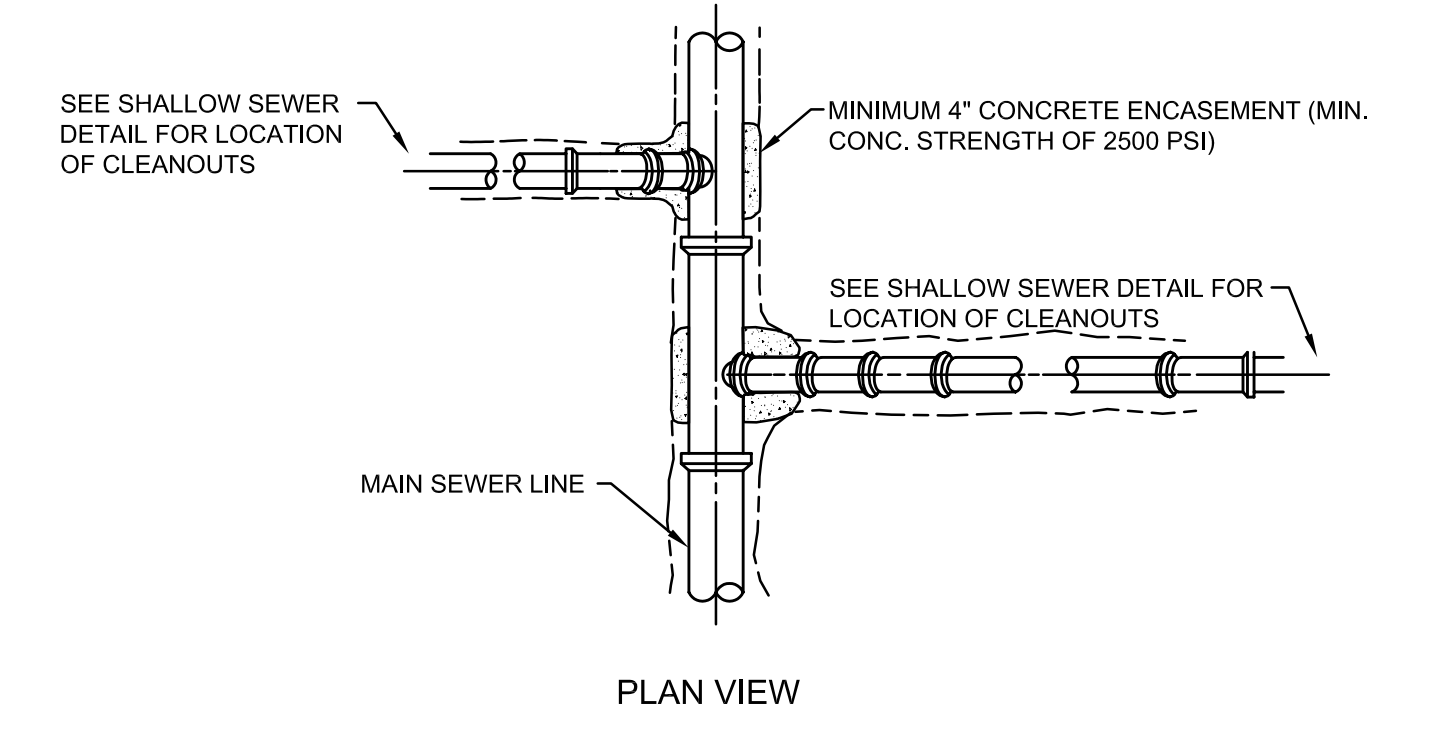
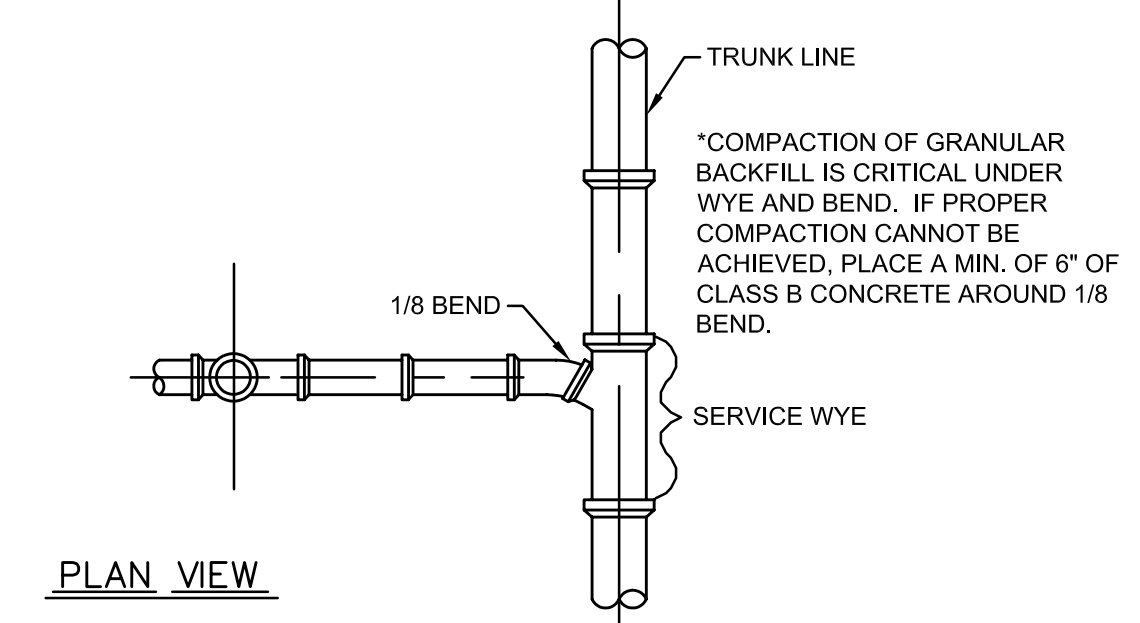
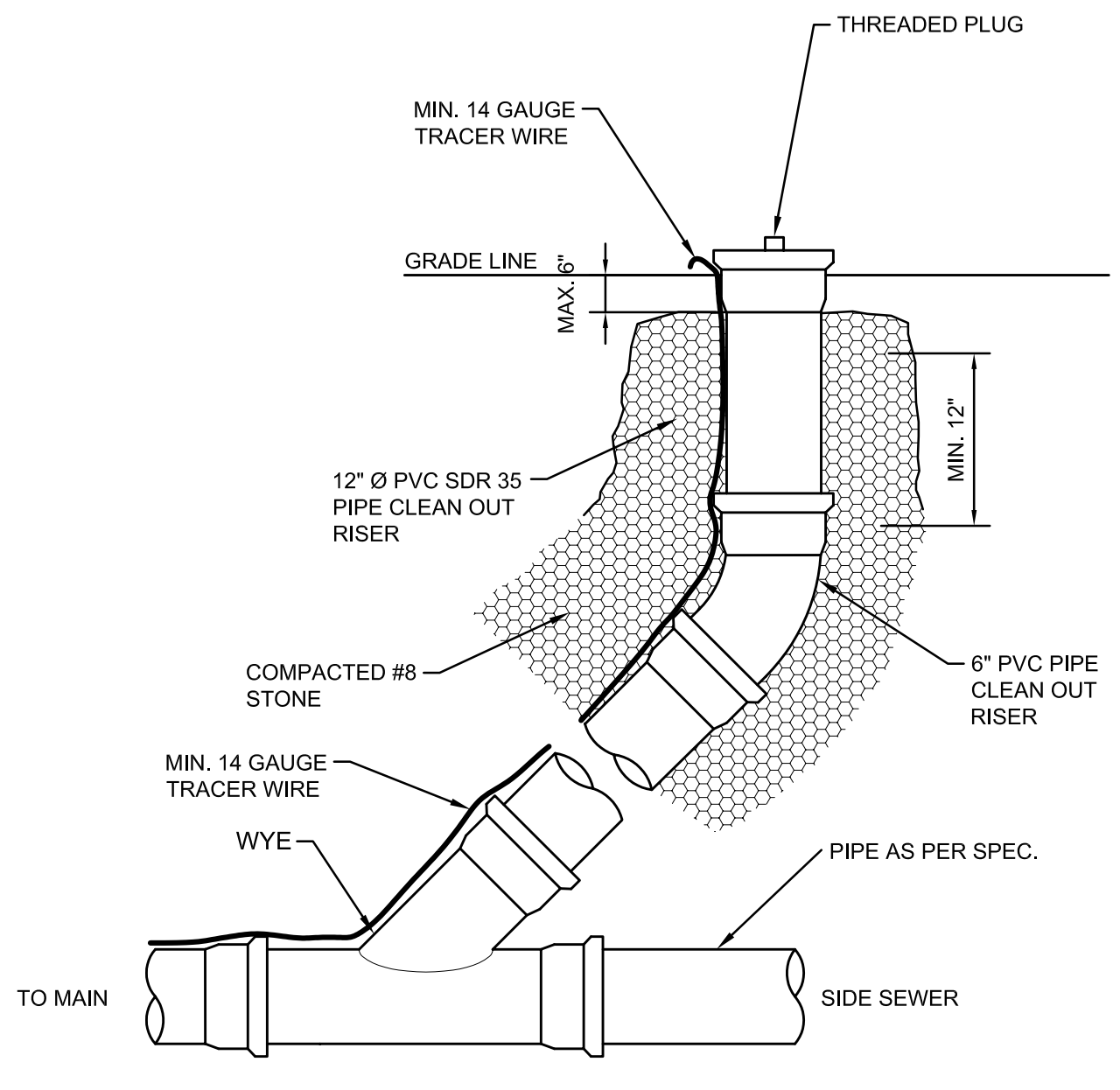
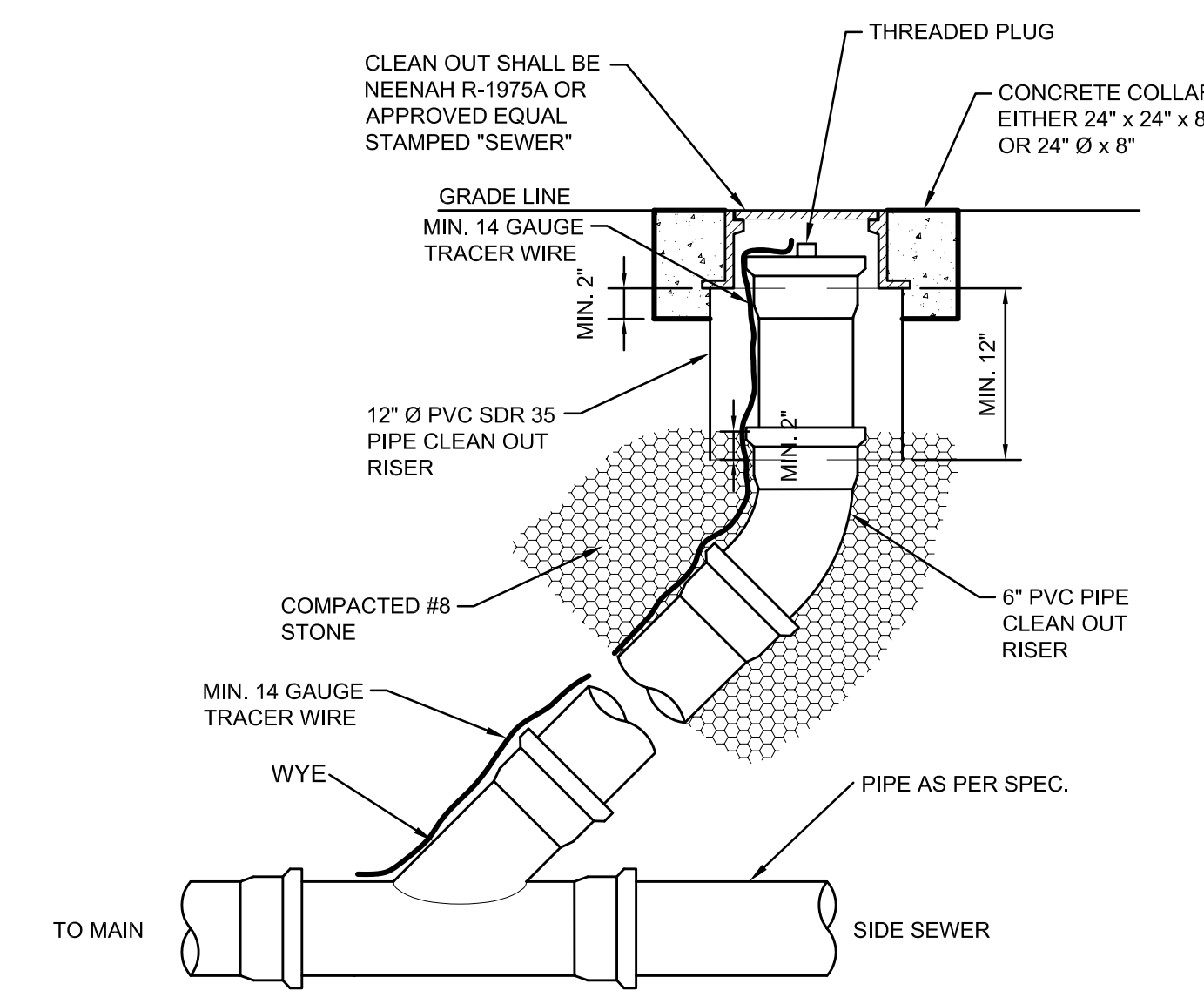
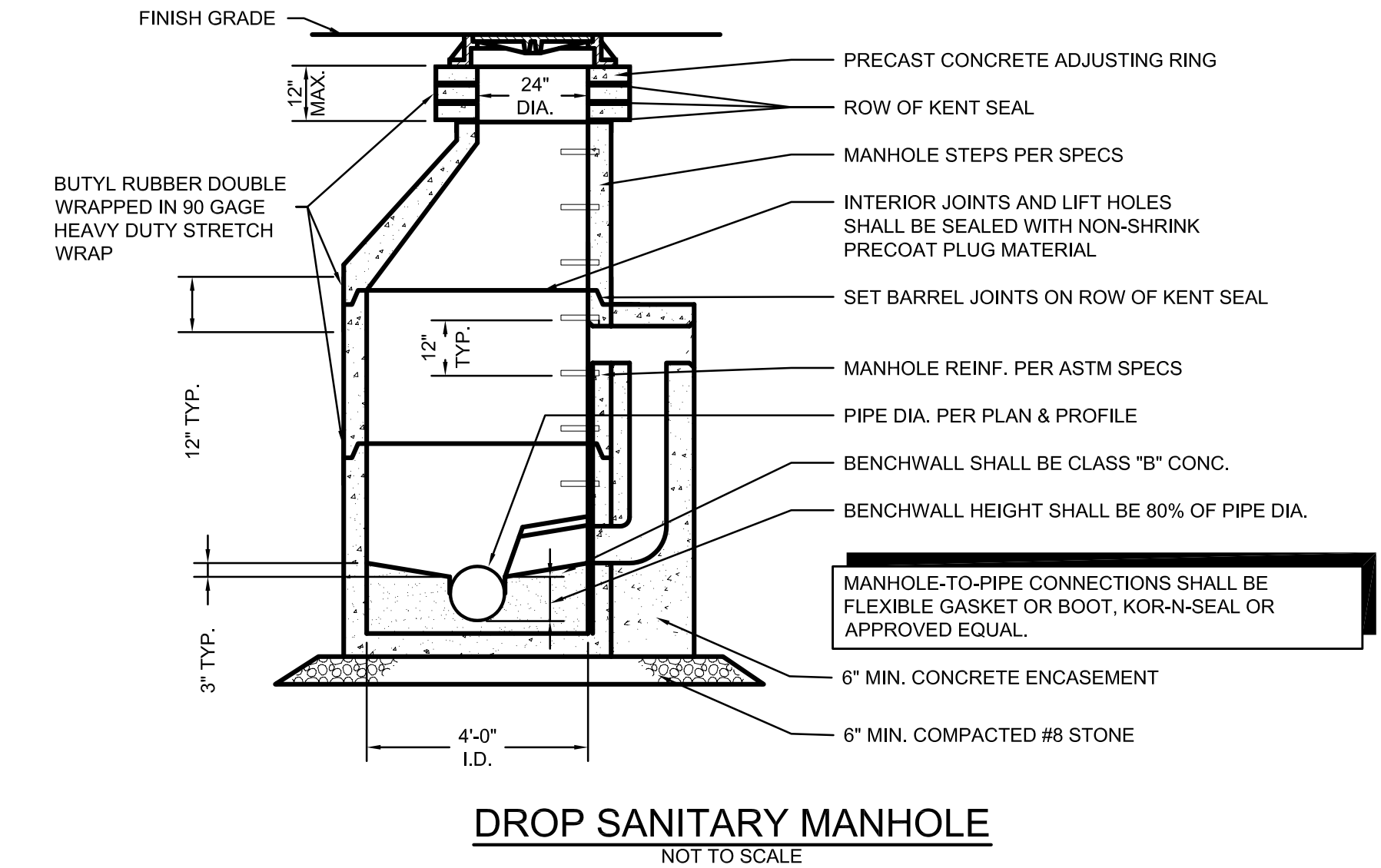
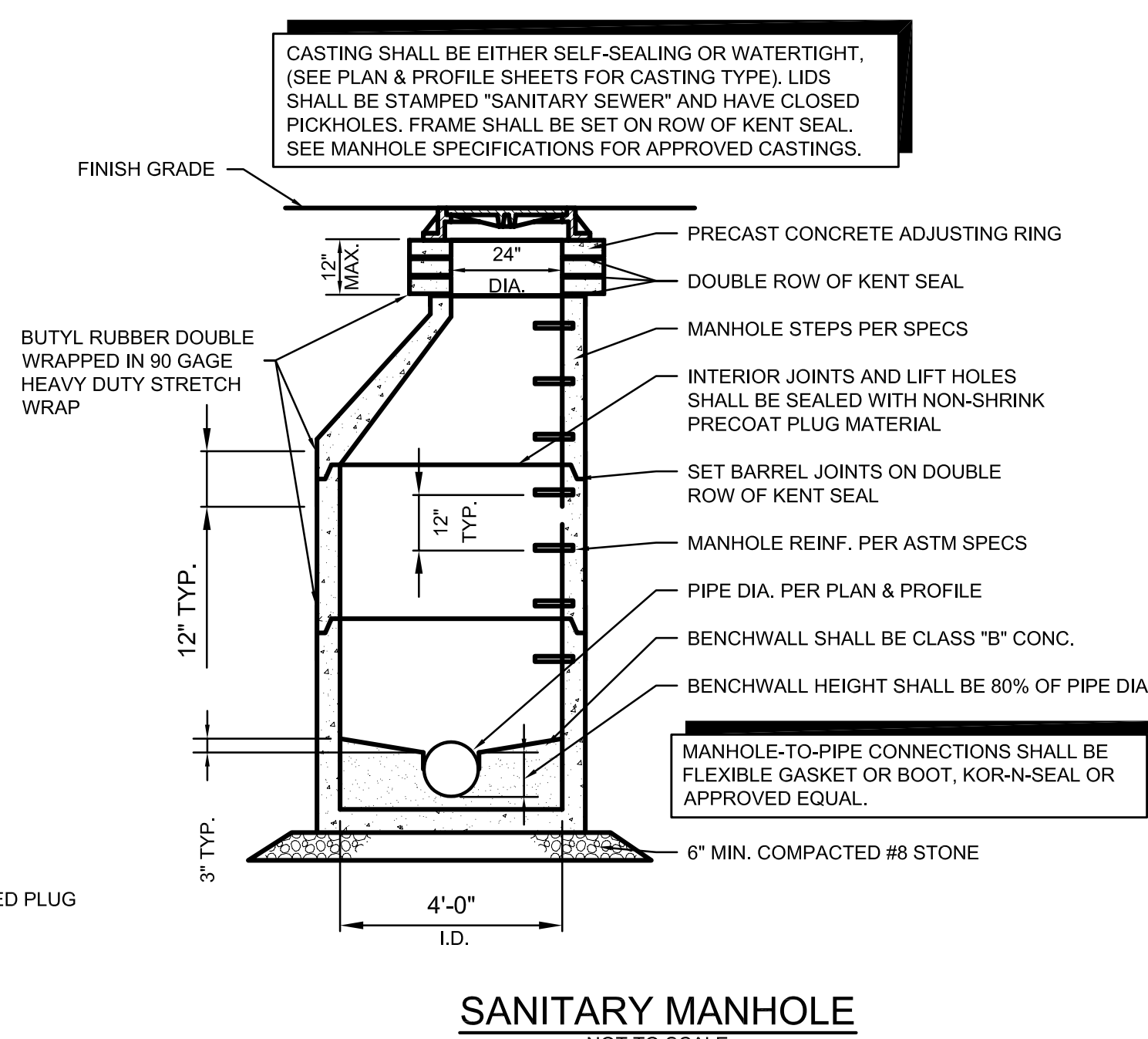
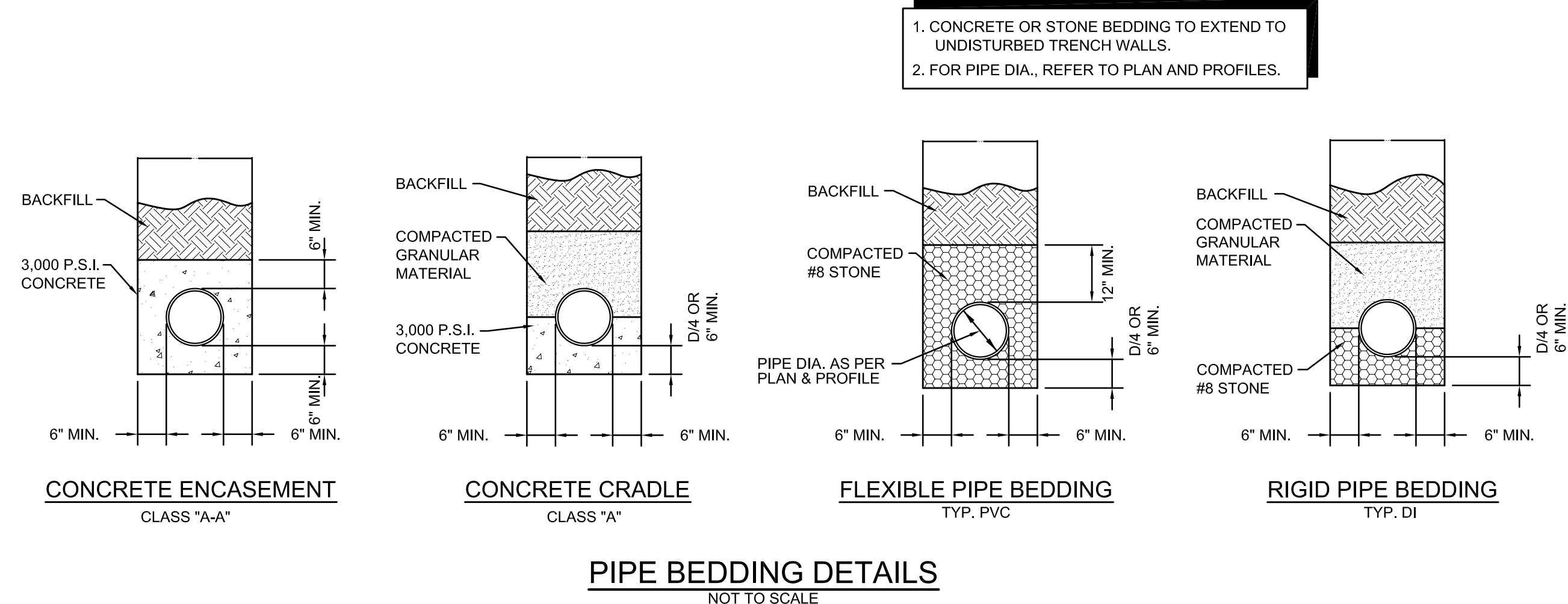

**SERVICE CONNECTION FOR SHALLOW SEWERS**  
LESS THAN 15' DEEP

**SERVICE CONNECTION FOR DEEP SEWERS (2 ALTERNATIVES)**  
15' DEEP AND OVER

NOTE  
1. ALL WORK SHALL BE IN ACCORDANCE WITH THE I.N.D.O.T. STANDARD SPECIFICATIONS. WHERE NO PROCEDURES FOR A PARTICULAR PORTION OF THE WORK ARE GIVEN, THE RECOMMENDATIONS OF THE HORIZONTAL EARTH BORING AND PIPE JACKING MANUAL OR THE AMERICAN RAILWAY ENGINEERING ASSOCIATION SHALL BE FOLLOWED.

REVISIONS		
REV. NO.	DESCRIPTION	DATE

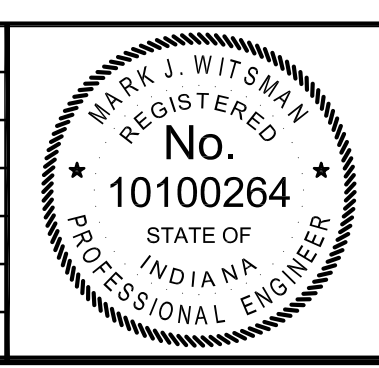

RECOMMEND FOR APPROVAL: *Mark J. Witsman* DESIGN ENGINEER 7/12/05 DATE

APPROVED: *Ronald D. Coyle* PUBLIC WORKS COMMISSIONER 7/12/05 DATE

APPROVED: *Mark J. Witsman* TOWN COUNCIL PRESIDENT 7/12/05 DATE

**TOWN OF McCORDSVILLE**

**TOWN STANDARDS**  
**SANITARY SEWER DETAILS**

**SHEET**  
**9**  
**OF**  
**10**

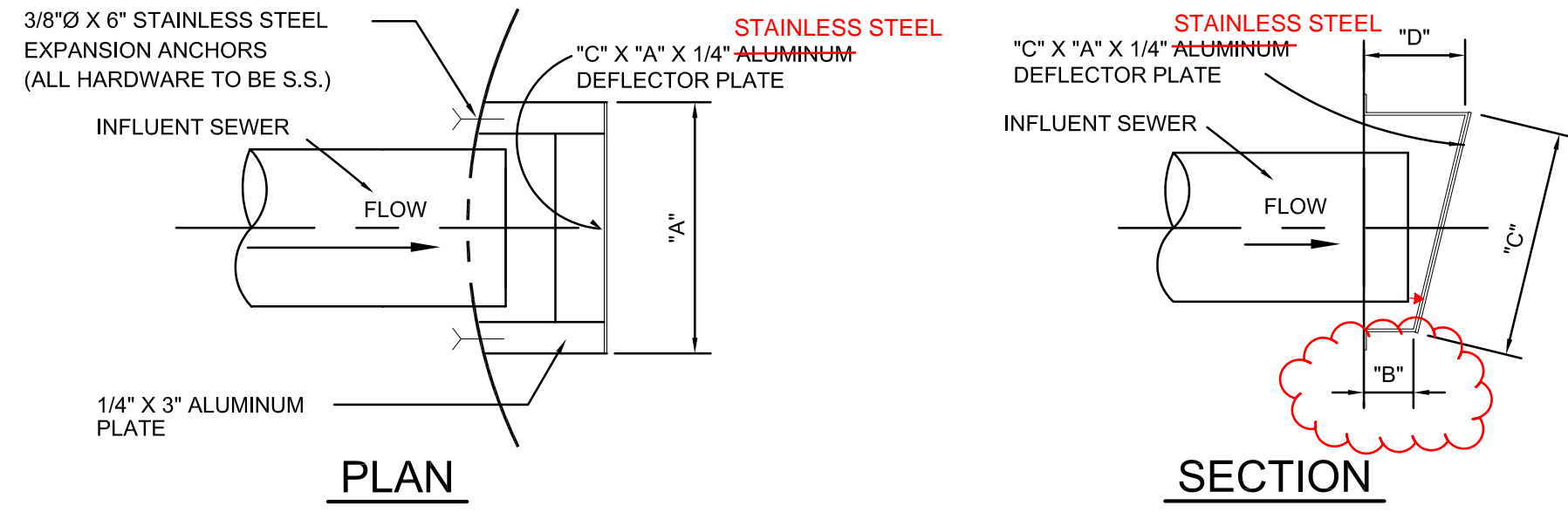
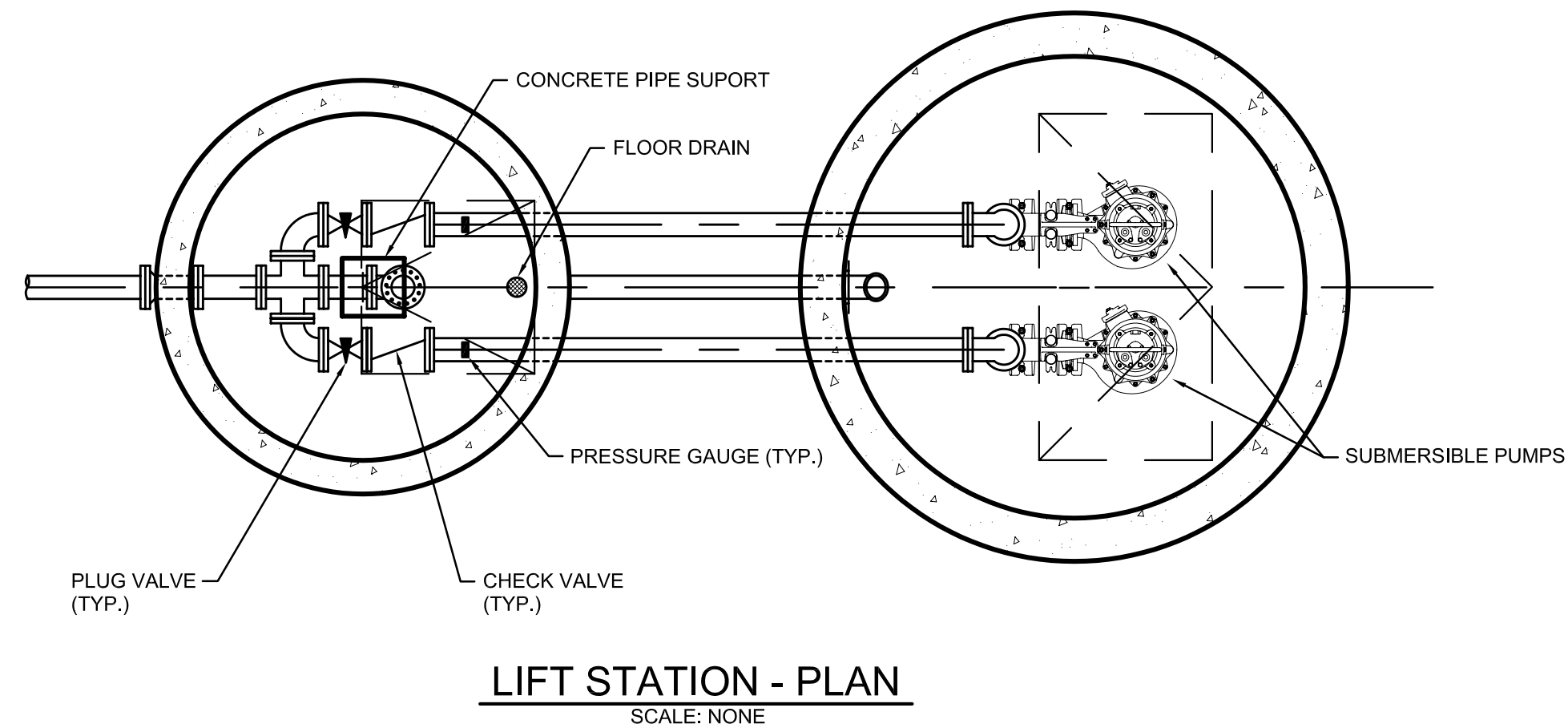

ALL SURFACES CONTACTING CONCRETE SHALL HAVE A BITUMINOUS COATING

MATERIALS SCHEDULE			
INFLUENT SEWER I.D.	"A"	"B"	"D"
8"-10"	19"	5"	13"
10"-14"	23"	5"	18"
14"-18"	27"	5"	23"
18"-22"	31"	5"	28"
22"-26"	35"	5"	33"

- GENERAL NOTES**
- Actual lift station dimensions, control settings, & pump selection to be indicated by the design engineer's certification sheet.
  - Pumps "A" and "B" shall be identical, centrifugal, submersible, solids handling, non-clog design capable of handling 3" sphere solids, fibrous material, sludge, and material found in typical raw sewage. Fit replaceable bronze wear ring to volute. Pumps shall be Flygt Hydromatic or approved equal. Manufacturer shall warrant the pumps for five years after installation. **Barnes**.

All mating surfaces intended to be watertight shall be machined and fitted with nitrile rubber o-rings with sealing complete when metal-to-metal contact is made, resulting in controlled compression of o-rings without specific torque limit. Fasteners shall be 316 S.S.

Mechanical shaft seal system running in an oil reservoir shall have separate, constantly lubricated lapped seal faces. The lower seal unit between media and oil reservoir shall consist of one stationary seat and one rotating ring held in place by its own spring. The rotating seat ring and the stationary seat ring shall be made of Tungsten-Carbide. The lower seal shall be removable without disassembling the seal chamber. The upper seal between seal chamber and motor shall be of the same design with its own spring. Seals shall be maintenance free, but shall be easily inspectable.

The lift station control panel shall be stainless steel construction, NEMA 4X rating mounted on an aluminum pedestal. The control cabinet shall house the following controls and indication: Warning lights for each pump, Indicator lights, Common alarm, H-O-A switches, Silence button, Pump alternator, Warning reset buttons, Relays, Heater, Surge protection, Phase monitoring, Hour meters, and a GFI 110 volt, single phase convenience outlet. Lower seal failure alarm shall be engaged by seal failure sensor provided in the seal chamber, which senses water intrusion through lower seal. A mini-float in the motor chamber which signals pump shutdown and alarm upon water intrusion through upper seal may be acceptable when approved by Town of McCordsville.

Over temperature alarm and pump shutdown shall be engaged by heat sensor attached to the motor windings. Motor winding and stator lead insulation shall be class F with maximum temperature capability of 155 degree C. Housing shall be filled with High-Dielectric Oil. Air filled housing may be acceptable when approved by Town of McCordsville. Pump and motor shall be designed to operate partially or fully submerged in pumped media without the use of cooling jackets.

Rail system shall enable the easy removal of the pump without the need for a person to enter the wet well. A non-corrosive FRP I-beam or schedule 40 stainless steel guide rails shall be provided for each pump. The guide rail shall be supported at the bottom by the discharge elbow, aligned perfectly plumb and securely affixed to access frame. One intermediate guide rail support is required for each 9' of guide rail length.

3.) Check valve shall use packing material to seal the integral shaft or hinge pin. O-ring side plugs and O-ring shall not be used to seal integral shaft or hinge pin. Check valve shall be provided with bolted covers for easy access to the discs and shall be outside adjustable weight & Lever and shall be Clow F-5382 or approved by Town of McCordsville.

4.) Provide sufficient lift chain, float mounting cable, and pump power & control cable to enable non-spliced field adjustment. 304L stainless steel lift chain w/ 4:1 safety factor shall have a minimum workload limit of 1100 pounds. Pump power & control cables shall be suitable for submersible pump applications and this shall be indicated by a code/legend permanently embossed on the cable. Provide sleeve and pin on pump control cable and locate on bracket near hatch.

5.) Plug valve shall be hand lever operated and shall be Dezurik Fig. 118, Clow F-5412, or Town of McCordsville approved equal.

6.) Pressure gauge shall be Terrice Model 450 LFB or Town of McCordsville approved equal. Drill & tap run of pipe to install pressure gauge.

7.) Piping not within 2 feet of wet well and valve pit shall be ~~D~~ Class 53, PVC ASTM D2241 SDR 21, PVC AWWA C900 or C905, or Town of McCordsville approved equal.

8.) Piping in and within 2 feet of wet well and valve pit shall be class 53 flanged ductile iron pipe.

9.) Piping, valves, and fittings in wet well and valve pit shall be factory primed Tnemec series 140 - 1211 to a dry film thickness of 5.0 to 11.0 mils and shall be field painted with Tnemec series 69 to a dry film thickness of 5.0 to 6.0 mils.

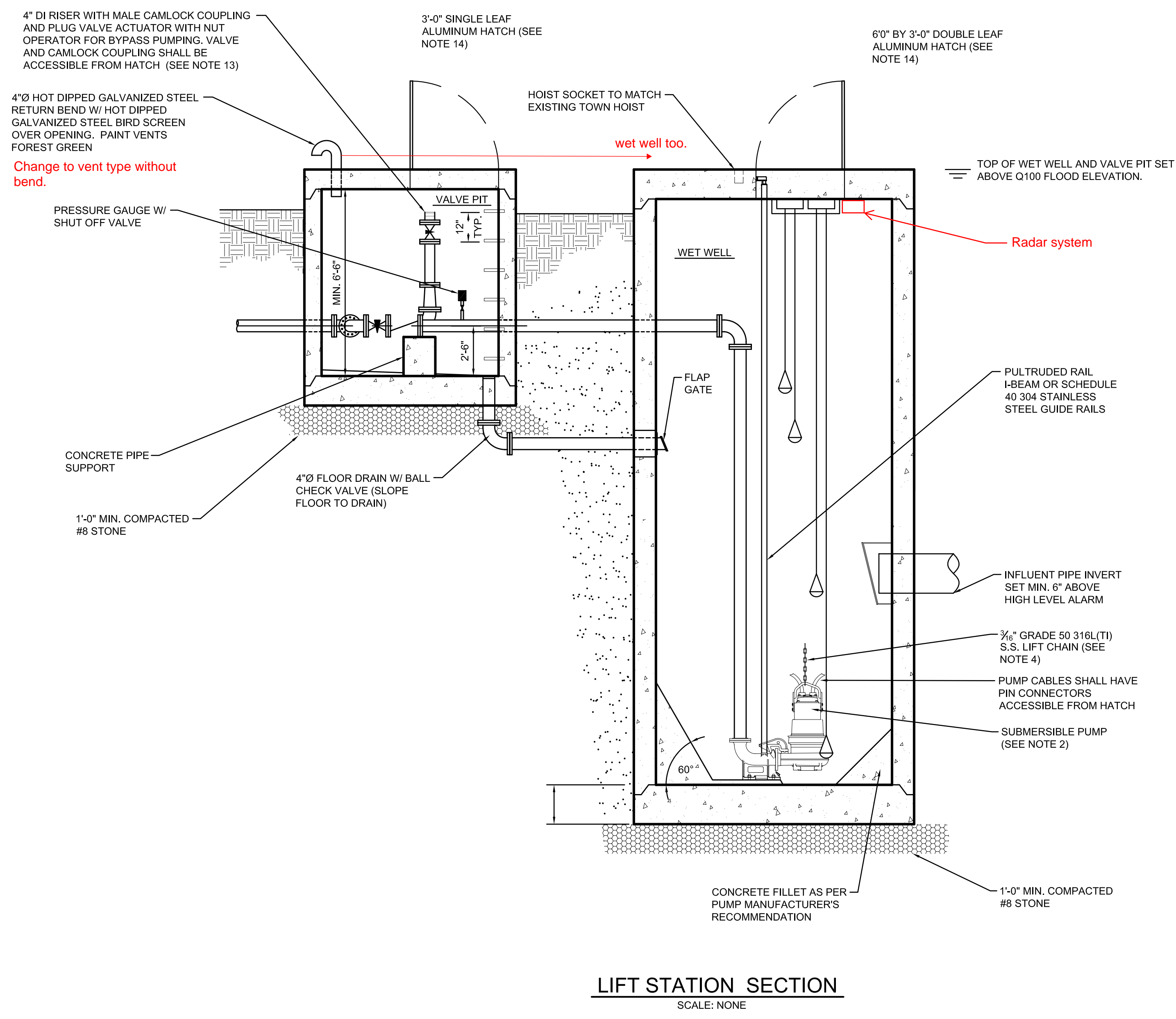

10.) Lift station and valve pit manholes shall be pre-cast concrete in accordance with ASTM C-478, with rubber gaskets equal to ASTM-443 with double row of 1/2" Hamilton Kent-Seal Extrudable Preformed Gasket material or Town of McCordsville approved equal. Exterior joints to have butyl rubber applied over the joint to a minimum of 1'-0" above and below the joint. Interior joints are to be sealed with non-shrink grout or precoat plug material.

11.) Valve pit shall be constructed on undisturbed soil or compacted granular material compacted with 1/2 inch nominal size to 95% standard proctor density.

12.) Horizontal projections from precast integral base and riser may be required to enable the weight of the vertical soil ring above the projection to resist buoyancy forces. See design engineer's certification sheet.

13.) Camlock flanged coupler and dust cap shall be used within valve vault. Camlock coupling and eccentric plug valve on by-pass line shall be 6" diameter with transition to force main size occurring with concentric reducer placed on top of base elbow. Fix operating nut for eccentric plug in vertical position to enable wrench operation from surface. Layout of all valve vault fittings and equipment to be based upon by-pass line being up close to hatch opening as shown.

14.) Aluminum hatches shall be Bilco, Halliday or Town of McCordsville approved equal. Leaf shall be 1/4" aluminum diamond plate live load rated to 300PSF. Access frames and covers shall be 1/4 inch thick one-piece, mill finish, extruded aluminum frame, incorporating a continuous concrete anchor. All surfaces contacting concrete shall have a bituminous coating. Hatch shall be provided with type 316 S.S. hardware throughout, compression spring operators, automatic hold-open arm with release handle, and non-corrosive locking bar used in conjunction with a Town of McCordsville supplied padlock. **MODIFY TO INCLUDE SAFETY**

15.) Sewer connection to wet well shall be KOR-N-SEAL, A-LOK, DURA-SEAL, or Town of McCordsville approved equal.

16.) Force main penetrations of wet well shall be KOR-N-SEAL, A-LOK, DURA-SEAL, or Town of McCordsville approved equal.

17.) Automatic pump control system shall include all necessary items and appurtenances, which might normally be considered a part of a complete system. System shall be supplied by one manufacturer, shall be factory assembled, wired and tested, and shall be per complete electrical drawings and instructions. Major components and sub-assemblies shall be identified as function with laminated, engraved, bakelite nameplates. System shall be built in a NEMA 4X S.S. enclosure suitable for the specified horsepower and voltage of the pumps. The outer door of the panel shall be a hinged dead front with provisions for padlocking. Inside shall be a separate hinged panel to protect all electrical components, H-O-A switches, run lights, circuit breakers, etc., mounted such that only the faces protrude through said panel with no wiring fixed to said panel. The manufacturer shall warrant the control center for one year after installation covering 100% parts and labor.

Provide the services of a factory-trained, qualified representative to inspect, to adjust, and to place the system in trouble-free operation and to instruct the operating personnel in the proper operation and care of the system.

All major components of control center shall be available from local sources. Pump manufacturer shall accept the control center in writing to ensure unit responsibility and warranty.

Provide a disconnect switch housed in a separate NEMA 4X S.S. enclosure with external operation handle capable of being locked in the "on" position. Provide 480 volt, 200 amp, 4 wire weatherproof receptacle, Crouse Hinds AR204 or equal, to match plug on existing portable generator.

Provide a Omni-site.net Crystall **WM** housed within the NEMA 4X control panel.

An incoming power terminal block shall be located at the bottom of the enclosure. A lightning arrester shall be provided at the terminal block and connected to each line of the incoming side of the power input terminals. A single main fusible/breaker disconnect switch of adequate size to provide power for control, operation, and appurtenance components shall be provided. Provide a circuit breaker and magnetic starter with each leg manual reset overload protected for each pump. Starters shall have auxiliary contacts on 3Φ applications to operate both pumps simultaneously. Provide a circuit breaker and transformer to power the control panel with 1Φ, 115 volt service for all control functions. Provide a green "run" light and H-O-A switch to enable field connections.

Materials and installation of the required equipment grounding shall be in accordance with NEC section 250-83(c). All wiring shall have not less than 600 volt insulation. Wiring and buss shall be in accordance with NEC, state, local, and NEMA standards. All wiring shall be color coded.

Minimum 4" diameter, schedule 40 conduit shall be provided from wet well to control panel enabling pump power & sensor cables and float switch cables to be easily pulled. Seal conduit at control panel to prevent sewer gases from entering. All conduits, fittings, or connections shall enter from the bottom of enclosures.

Sump level rise to lead pump run float causes lead pump to operate. Lead pump operating and sump level falling to pumps off float causes lead pump to shut off. Lead pump operating and sump level rising to lag pump run float causes lag pump to operate. Lag pump operating and sump level falling to pumps off float causes both pumps to shut off. Sump level rise to high level alarm causes high level alarm to operate. An alternating relay shall be provided to cause pumps to alternate whenever pumps off float is de-energized. If one pump fails for any reason, the remaining pump shall operate upon sump level rise to lag pump run float. An hour meter shall be provided for each pump to record the elapsed operating time of each pump.

18.) Four manuals shall be presented to the owner, which shall include the following minimum information: 1) Operation instructions, 2) Maintenance instructions, 3) Recommended spare parts list, 4) Lubrication schedule, 5) Structural diagrams, 6) As-built wiring diagrams, & 7) Bill of materials.

Wet well pump operation shall be controlled with a radar level system with float Vega radar sensor or approved equal. PLC to control the level sensor and float back up. Getting email with language from BLAnderson.

Wet well pump operation shall be controlled with a VegaPuls C21 radar sensor for continuous level measurement along with IDEC FT1A SmartAXIS controller or engineer approved equal.

REVISIONS		
REV. NO.	DESCRIPTION	DATE
1	Various changes in red	4/18/2023



RECOMMEND FOR APPROVAL: *Mark J. Witsman* DESIGN ENGINEER 7/12/05 DATE

APPROVED: *Ronald D. Cooney* PUBLIC WORKS COMMISSIONER 7/12/05 DATE

APPROVED: *Mark Witsman* TOWN COUNCIL PRESIDENT 7/12/05 DATE

**TOWN OF McCORDSVILLE**

**TOWN STANDARDS**  
**SANITARY SEWER LIFT STATION**  
**STANDARDS & GUIDELINES**

**SHEET**  
**10**  
**OF**  
**10**